

Ultra**LED** SERIES



Information specifically for:

DL-ULEDDRIVER4

This manual contains important information.
Please read before operating fixture.



10900 Palmbay Drive • Orlando, FL 32824 U.S.A.

Voice: 407-857-8770 Fax: 407-857-8771

www.techni-lux.com

Table of Contents

IMPORTANT INFORMATION.....	2
UNPACKING.....	3
SAFETY INSTRUCTIONS.....	3
INTRODUCTION.....	4
FEATURES.....	4
SPECIFICATIONS.....	4
PRODUCT VIEW.....	4
SETUP.....	5
Mounting.....	5
Unit Linking.....	5
DMX Background.....	6
Adapter 5-to-3pin.....	7
AC Power.....	7
OPERATING INSTRUCTIONS.....	7
Menu Map.....	8
System Setup.....	8
System mode.....	8
DMX mode.....	9
Auto mode.....	9
Sound mode.....	10
Master/Slave.....	10
Fuse Replacement.....	10
Specifications.....	10

sp.1	sp.2	sp.3	sp.4	sp.5	sp.6	sp.7	sp.8	sp.9	sp.10
30s	20s	10s	7s	5s	4s	3s	2s	1s	0.5s

► Sound Activation Mode

In this mode, the system runs built-in program to the beat of music. Step color changing and color chasing are available in Sound mode.

1. Press Menu button until display reads “System Mode [xxx]”, use Up/Down button to select sound program:

- Sound Prog 01: color step changing to sound
- Sound Prog 02: color cross fade to sound
- Sound Prog 03: color strobing to sound

2. Press Enter button to reach Sensitivity and use Up/Down to adjust sensitivity level.

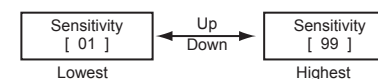

► Master/Slave Mode

For large venue, multiple systems can be run in sync as Master/Slave. Use DMX cables to link the Drivers together.

- One of DL-ULEDDRIVER4 in the daisy chain is to be set as Master and this Master must work under Auto or Sound mode.
- Other drivers are to be set in Slave mode.
- Operate the Master Driver in Auto and Sound mode to run the whole system.

Fuse Replacement

Remove the damaged fuse from its holder and replace with exact same type fuse.

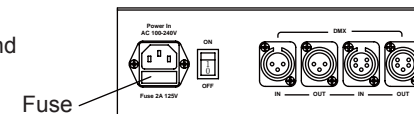

SPECIFICATIONS

- Output
 - Port 1-4: 48V DC 350mA, 36W / Port Max.
 - Port 5-6: 48V DC, 144W / Port Max.
- Total load (6 ports): 150W Max.
- Power Input: 100-240vAC 50/60Hz
- Size: 8.85" x 3.02" x 11.57"
225mm x 76.8mm x 294mm
- Weight: 3.0kgs/6.6lbs

IMPORTANT INFORMATION!

In order to optimize the recovery and recycling of the materials that old appliances contain and reduce the impact on human health and the environment, ensure that this product is recycled at the end of its life.



► DMX Mode

In DMX mode, each output port takes up 6 DMX channels. You can address all ports at the same starting channel to control the whole system simultaneously. Or you can address each port individually.

Do not overlap DMX start channel addresses when individually setting each port start address differently!

1. Press Menu button until display reads “System Mode [xxx]”, then use Up/Down button to select [DMX] and press Enter button. LCD display reads:

Port1 DMX_addr
[1] 001

2. Use Enter to switch between Port and DMX_addr.
3. Use Up/Down to select port number and set DMX address.

DMX Channels

CH1	CH2	CH3	CH4	CH5	CH6
Value:231-255 Sound Activation	—	—	—	—	—
Value:151-230 Color Macro & Auto programs	select of 18 colors or 2 programs	speed slow to fast	—	Strobe: 21-255 slow to fast 0-20 no function	Dimming 0-255 Intensity 100% to 0
Value:0-150 Color mixing	Red Intensity 0-100%	Green Intensity 0-100%	Blue Intensity 0-100%	Strobe: 21-255 slow to fast 0-20 no function	Dimming 0-255 Intensity 100% to 0

Notes:
When ch. 1 value is from 151 - 230, DMX value and functions of ch. 2 as below

1 - 12	13 - 25	26 - 38	39 - 51	52 - 64	65 - 77	78 - 91	92 - 103	104 - 116	117 - 129
red	green	blue	yellow	magenta	cyan	white	orange	purple	yellow green
130 - 142	143 - 155	156 - 168	169 - 181	182 - 194	195 - 207	208 - 220	221 - 233	234 - 246	247 - 255
pink	sky- blue	orange- red	pale- green	chocolate	light- blue	voilet	gold	step change	cross fade

► Auto Mode

In this mode, you can select one of 18 preset static colors or 6 color-changing/cross fade/chasing programs to run the whole system.

1. Press Menu button until display reads “System Mode [xxx]”, use Up/Down button to select System Mode [Auto] and press Enter button. Display reads:

Prog xx
[xxx]

2. Use Up/Down button to select program.
3. When color-changing/cross fade/chasing programs (prog19-24) are selected, press Enter button to access speed, effect, color and dimmer.

10 speed from slow to fast as below:



IMPORTANT INFORMATION

Save original packing and documentation for warranty, service and return issues.

Limited Warranty: This warranty covers defects or malfunctions in this equipment. This warranty lasts for a period of one year from date of purchase. It is the owner's responsibility to provide invoices for proof of purchase, purchase date and dealer or distributor. If purchase date can not be provided, warranty period will start at manufacture date. It is the sole discretion of Techni-Lux to repair or replace parts or equipment. All shipping will be paid by purchaser. This warranty does not cover lamps, fuses, belts, power semiconductors, relays, cleaning, standard maintenance adjustments or normal wear items or any problem resulting from the following: improper wiring, incorrect voltage (including low or over voltage conditions and lightning), abuse, misuse, improper maintenance or an act of God or damage resulting from shipping. Warranty will be null and void if the product is altered, modified, misused, damaged, or subjected to unauthorized repairs. Lamps are covered by relevant manufacturer warranty. This warranty gives you specific legal rights, and you may also have other rights which vary from state to state. Any liability for consequential and incidental damages is expressly disclaimed. No other warranty, expressed or implied is made. Techni-Lux liability in all events is limited to, and shall not exceed, the purchase price paid.

Returning equipment and Repairs: All returns must be accompanied by a Return Merchandise Authorization (RMA) number and sent pre-paid. Contact the dealer or Techni-Lux directly to obtain an RMA. The RMA number must be clearly listed on the shipping label. Due care must be exercised in packing all merchandise to be returned. All repairs must be accompanied by a written explanation of the claimed problem or error encountered. Techni-Lux is solely responsible for determining a product's eligibility for coverage under warranty. If returning for consideration of credit, all accessories and documentation, original protective material and cartons must be included and the equipment, packing and carton must be in new resalable condition. Credit for returned merchandise will be issued at the lowest current price and is subject to a restocking fee. No returns accepted on discontinued items. Techni-Lux is not responsible for merchandise damaged in transit and reserves the right to refuse any return that is damaged by the carrier, not accompanied by a Return Authorization Number (RMA#) or sent by freight collect.

Claims: All claims must be made within seven (7) days of receipt of merchandise. Any physical damage must be reported to carrier upon receipt of merchandise.

Please record the following information for future reference:

Model Number: DL-ULEDDRIVER4

Serial Number: _____

Dealer: _____

Date of Purchase: _____

www.Techni-Lux.com

UNPACKING

Immediately upon receipt, carefully unpack and inspect the unit to verify that all parts are present and have been received in good condition. If any parts appear damaged from shipping or the shipping carton shows signs of mishandling, retain all packing material for inspection and notify the shipper immediately. Save all original packing and carton. In the event that the merchandise is to be returned, the original carton and packing must be used. The customer will be billed for a new carton and packing if merchandise is received without the original carton and packing. The plastic bag shipped with the unit can be used to keep the unit clean if stored or installed in a temporarily dusty environment. Do not operate unit with plastic bag in place.

Save shipping materials

The packing and carton are designed to provide the unit with protection during shipping. Save original packing and documentation for warranty, service and return issues. Additional charges will be applied to return items not received in original or incomplete packing.

Claims

Physical damage must be reported to the Freight Carrier or Shipping Company upon receipt of merchandise. Damage incurred in shipping is the responsibility of the Freight Carrier or Shipping Company. It is the customer's obligation in the event that merchandise is received damaged caused by shipping to notify the Freight Carrier or Shipping Company immediately. All other claims not related to damage incurred during shipping must be made to the Dealer or Distributor within 7 (seven) days of receiving merchandise.

Returns

Returned merchandise must be sent prepaid, in the original packing with a Return Merchandise Authorization number (RMA) clearly listed on the shipping label. Items sent by Freight Collect or without a RMA number will be refused. Call your sales person and request a RMA prior to shipping. Be prepared to provide the model number, serial number and a brief description of the nature of the return. Shipping damage resulting from inadequate packaging is the customer's responsibility. Customer will be charged additional shipping charges to return products received in non original packing and or cartons.

SAFETY INSTRUCTIONS



WARNING!!! To reduce the risk of fire, electric shock, or injury to persons, follow these important safety instructions:

- This product is intended for indoor use only!
- Always turn off, unplug power and allow unit to cool before servicing.

Menu Map

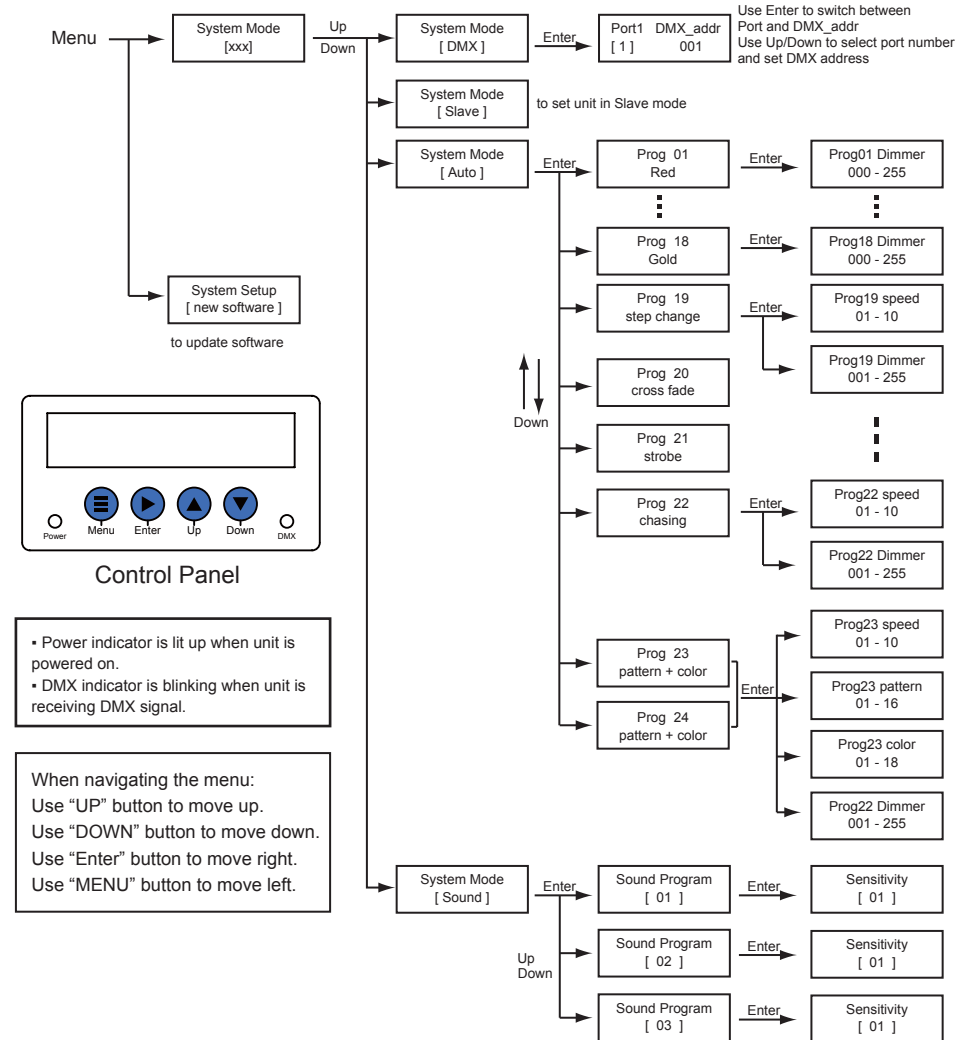

► System Setup [new software]

This mode is designed for factory to upload software through USB port. Your product has been tested before shipment. Check with local distributor or dealer's web site if updated software is available.

► System Mode [xxx]

Press MENU button until display reads "System Mode [XXX]", then use UP/DOWN button to scroll through" DMX, Slave, Auto, Sound.

The DMX Standard calls for connections between DMX compatible equipment to be made using 5 pin XLR connectors. However, it is common to see fixtures with 3 pin XLR connectors as these types of balanced or "Lo-Z" cables are common in the audio industry. In either case, pin numbers are the same and carry the same signals.

Pin	Connection
1	Common (Shield)
2	Data Negative (S- or Cold)
3	Data Positive (S+ or Hot)
4	n/c (not used)
5	n/c (not used)

Adapter 5-to-3 pin

Numbers designating each pin can be found on connectors. Converting between the two XLR types is done in a pin-to-pin fashion. Connect the shields to pin 1, then connect pin 2 to pin 2 and pin 3 to pin 3. This is true for converting either 5 to 3 pin or 3 to 5 pin regardless of either connector's gender. Pins 4 and 5 are not used on the 5 pin XLR connectors.

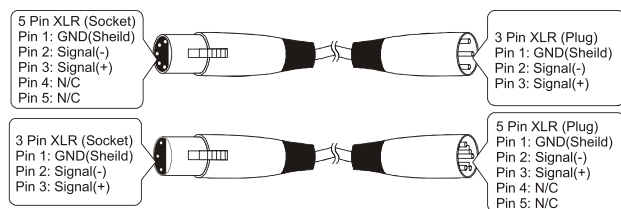

AC Power

The unit is designed to work on 100V-240V 50Hz/60Hz.

Warning!!!

All units must be connected to a circuit with a suitable Earth Ground.

OPERATING INSTRUCTIONS

This Driver offers 4 working modes: Auto, Sound, DMX and Master/Slave mode

1. Connect the unit to mains supply.
2. Turn on power switch and wait a few seconds until LCD display reads:

UltraLED
System Ready

3. Use buttons on Control Panel to set up and operate.

- Ensure that unit is properly grounded.
- Please keep this User Guide for future consultation.
- Always make sure that you are connecting to the proper voltage and that the line voltage you are connecting to is not higher than that stated on decal or rear panel of the unit.
- To prevent risk of fire or shock, do not expose unit to rain or moisture.
- The unit must be installed in a location with adequate ventilation, at least 50cm from adjacent surfaces. Be sure no ventilation slots are blocked.
- Always disconnect from power before servicing or replacing fuse.
- Make sure power cord is never crimped or damaged.

INTRODUCTION

DL-ULEDDRIVER4 is a 4 output power and control unit for the UltraLED series range of products. It is compact and easy to use. Please read this user guide thoroughly before operation. Proper use and care of this product will prolong the life of this device.

FEATURES

- 4 working modes: Auto, Sound, DMX, Master/Slave
- DMX control using 6, 12, 18, 24, 30 or 36 channels
- 6 output ports and each port can be addressed individually
- 18 preset colors + 6 built-in programs with variable dimmer and speed
- Software updateable via USB port
- LCD digital display menu for all settings
- Sound activation accessible via DMX
- Linkable via Master/Slave
- Wall mounted, free standing, or clamp mounted
- Both 3 and 5 pin XLRs In/Out for DMX control

PRODUCT VIEW



SETUP

Mounting



Always consult a qualified professional when installing. This unit may be wall mounted, free standing, or clamp mounted. When selecting a mounting position, take into consideration access for routine maintenance. This unit may be mounted in any position provided there is adequate room for connections. Mount the unit securely using one mounting clamp and a safety cable. The mounting hole size provided is 1/2". Safety cables must always be attached to the unit. Do not mount in a place where the unit will be exposed to rain, high humidity or extreme temperature changes. This unit is for dry / indoor use only.

Unit Linking

DL-ULEDDRIVER4 is designed for the UltraLED series range of products. To run your light shows of one or more units using a DMX-512 controller or to run synchronized shows on two or more units in master/slave operating mode, you need DMX cables to link the units from DMX IN to DMX OUT.

IMPORTANT!

- 1) The units are linked in serial. Open circuit will cause malfunction.
- 2) Always connect OUT-1 of Splitter with a ULED unit and OUT-2 to the next Splitter.



SPLITTER

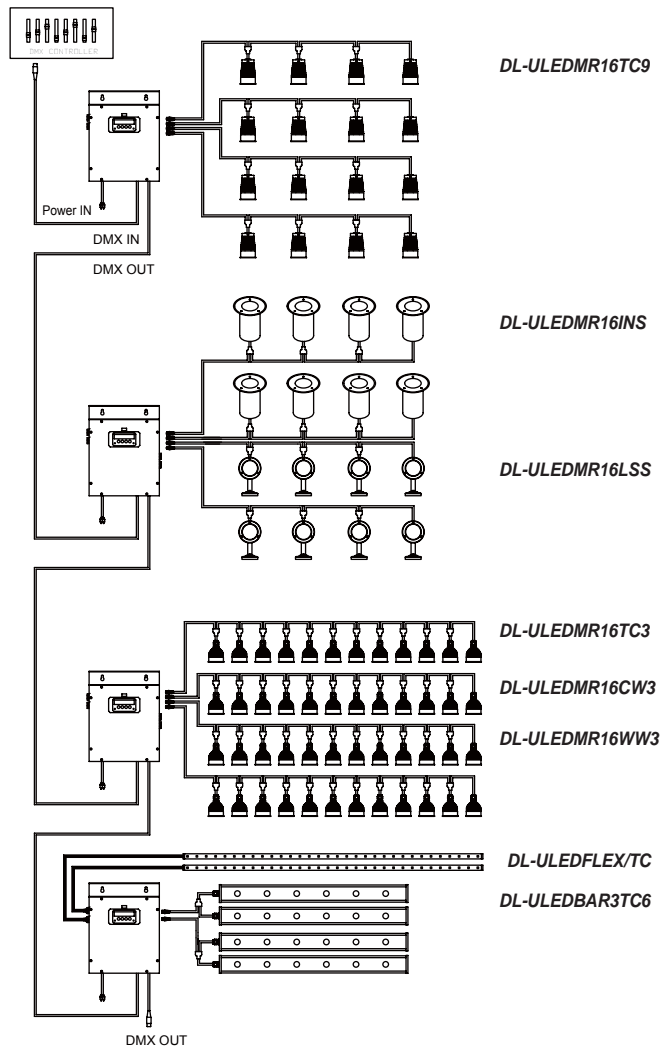

DMX-512 Background

DMX-512 is a digital data transmission standard developed by the United States Institute for Theater Technology (USITT). It is designed to enable control of lighting equipment, originally dimmers. DMX deals solely with the formatting of data for transmission and does not dictate how the data is created or used.

Under DMX, signals are transmitted in much the same way a computer modem transmits data. The Data, divided in to channels, is "Framed" using a start bit, high (1), eight data bits and finally, two stop bits, both high (1). DMX uses no parity to check the integrity of the signal. Instead, DMX relies on the ultra low probability of an error occurring in the same place when the data is resent. The rate at which data is sent is fixed at 250k bps, almost four and a half times faster that a 56k modem. This speed allows all data on a DMX chain to be updated more than 44 times every second.

The transmitted data follows a specific format. DMX allows for 512 channels each with eight data bits, giving each channel the possibility of 256 values. When a data "Packet" is sent, all channels are transmitted one after another. Even if the data on a specific channel has not been changed, it must be sent. In a packet, a "start code" of all zeros is sent before the data to identify the signal as a Standard DMX transmission. This start code is transparent to the user and is handled by the controller.

The physical signals are transmitted using a twisted pair of wires and a common shield, a configuration called Balanced. The controller and all receiving equipment are connected using a "Daisy Chain" connection. The signal is jumped from the controller to a piece of DMX equipment. From there, the signal is jumped to the next piece of equipment and so on until the last piece of equipment is connected. No branches are allowed and the signal does not come back to the controller. The final piece of equipment will have only one cable connection. As a result, all equipment connected to the chain will see exactly the same signal whether it is first or last. When connecting equipment, no particular attention needs to be paid to the order in which the equipment is connected. Depending on the conditions and equipment, a line terminator may be required. If there is any question, in most circumstances the addition of a terminator will not degrade the signal. To make a terminator, add a 120-ohm resistor between the Signal Data Negative and Signal Data Positive pins of a connector in the last piece of equipment in the chain.

