

Giotto spot 1200

Professional Moving head



User's Manual rel. 1.00



GB

I

D

F

E

General instructions

Read the instructions in this handbook carefully, as they give important information regarding safety during installation, use and maintenance.

Be sure to keep this instruction manual with the fixture, in order to consult it in the future. If the fixture is sold or given to another operator, make certain he or she also receives the manual, to be able to read about its operation and follow the relative instructions.

- * This fixture is not intended for home use.
- * After having removed the packaging, check that the fixture is not damaged in any way. If in doubt, don't use it and contact an authorized SGM Technical Service Centre.
- * Packaging material (plastic bags, polystyrene foam, nails, etc.) must not be left within children's reach, as it can be dangerous.
- * This fixture must only be operated by adults. Do not allow children to tamper or play with it.
- * Electrical work necessary for installing the fixture must be carried out by a qualified electrician or experienced person.

Never use the fixture under the following conditions:

- * In places subject to excessive humidity
 - * In places subject to vibrations or bumps.
 - * In places with a temperature of over 45°C or less than 2°C
 - * Protect the fixture from excessive dryness or humidity (ideal conditions are between 35% and 80%).
 - * Do not dismantle or modify the fixture.* Make certain that no inflammable liquids, water or metal objects enter the fixture.
 - * Should any liquid be spilled on the fixture, disconnected the power supply to the fixture immediately. * In the event of serious operating problems, stop using the fixture immediately and either contact the nearest SGM sales point for a check or contact the manufacturer directly.
 - * Do not open the fixture - there are no user serviceable parts inside.
 - * Never try to repair the fixture yourself. Repairs by unqualified people could cause damage or faulty operation. Contact your nearest authorized service centre.
- **When carrying out any work, always comply scrupulously with all the norms (particularly regarding safety) currently in force in the country in which the fixture's being used.**

Always insist on original spare parts being fitted.

General warranty conditions

- The unit is guaranteed for 12 months from the date of purchase against manufacturing material defects. Breakdown caused by carelessness and improper use of the fixture is excluded.
- The guarantee is no longer valid if the unit has been tampered with or repaired by unauthorized personnel. Replacement of the fixture is not foreseen by the guarantee.
- External parts, knobs, switches, removable parts and lamps are excluded from the guarantee: these are covered by their manufacturers' guarantee conditions.
- Transport costs and related risks are borne by the fixture's owner. The guarantee is valid to all effects only on presentation of the guarantee certificate to the manufacturer or the nearest SGM technical assistance centre.
- Always quote the unit's serial number and model when contacting your reseller for information or assistance.

***Protect the environment: don't throw packing material into your garbage can
- return it to your SGM retailer or take it to the nearest
special waste collection point.***

index

4	Intruduction
5	Main features
7	Technical Specifications
8	1.0 - Installation
8	1.1 - Locking and unlocking the mechanism
8	1.2 - Access to the interior
9	1.3 - Fitting the lamp
9	1.4 - Lamp alignment
10	1.5 - Power cable construction
10	1.6 - Giotto Spot's power supply
10	1.7 - Installing the fixture on a support structure
11	1.8 - Positioning the fixture
11	1.9 - Installing clamps
12	2.0 - Signal cable construction
12	2.1 - Construction of the DMX terminator
13	2.2 - RS-232 connection
14	3 - Microcomputer control
14	3.1 - Navigating in the menu
16	3.2 - Allocating the start channel
17	3.3 - Pan direction
17	3.31 - Limiting Pan
17	3.4 - Tilt direction
17	3.41 - Limiting tilt
18	3.5 - Inverting Pan/Tilt
18	3.6 - Lamp elapsed time meter
18	3.61 - Resetting the lamp's elapsed time meter
18	3.7 - Lamp strike counter
18	3.71 - Resetting the lamp's strike counter
19	3.8 - Fixture operating time meter
19	3.9 - Input signal
19	3.10 - Pan/Tilt resolution
19	3.11 - Remote control of lamp ignition
19	3.12 - Remote fixture reset
20	3.13 - Display brightness
20	3.14 - Display reading position
20	3.15 - Test functions
20	3.16 - Control of the acceleration of movement speed
20	3.17 - DMX DLY
21	3.18 - SLLF
21	3.19 - Reserved functions
22	4 - Giotto Spot 1200 control channels
22	5 - Iris channel -ch5 -
23	6 - Color channel - CH6-
24	7 - Gobo channel - CH7 -
25	8 - Shutter/Strobe channel - CH8 -
25	9 - Dimmer - ch 9 -24
26	10 - Gobo rotation - ch 10-
25	11 - Prisms - ch 11 -
26	12 - Prism Rotation - ch 12 -
27	13 - Electronic focus - ch 13 -
27	14 - Additional lenses - ch 14 -
27	15 - Color Filters - ch 15 -
28	16 - Frost - ch 16 -
28	17 - Mspeed - ch 17 -
28	18 - Lamp ignition and remote reset- ch 18 -

Introduction

Giotto Spot 1200 is an innovative professional SGM moving head fixture designed and built for use in large show events, theatres, TV studios and entertainment venues in general.

The result of SGM's many years' experience in mechanical and electronic design, thanks to its avant-garde performance, Giotto Spot 1200 is one of the world's top fixtures.

The use of an MSR 1200SA discharge lamp and a perfect optical system in fact make it one of the best fixtures on the market today as far as power and luminosity are concerned.

The lamp and electronics are powered by an electronic ballast entirely designed by the SGM Research & Development Centre which ensures flicker-free light, bright steady light beams and lower weight than fixtures with traditional ballasts. Movement precision and speed are guaranteed by stepper motors, controlled by no less than 5 microprocessors. An ingenious system allows the fixture to be automatically repositioned in the event of accidental head movement.

Thanks to its truly innovative technical features, Giotto Spot 1200 is a fixture able to offer Lighting Designers excellent solutions to all their needs.



Main features

Lamp

Giotto Spots use a Philips MSR 1200SA 6500°K discharge lamp, without doubt the ideal light source for this type of fixture, as it combines reliability and long life (approximately 500) with astonishing luminous power.

Effects

- Iris
- Linear 0÷100% dimmer
- Shutter/Strobe from 1-10 fps - can run in music sync
- Electronic focus
- 72 colors + effects wheel
- Colorchanger with music sync and/or blackout
- 4 rotary indexed gobos + 4 fixed (all interchangeable)
- 24 gobo combinations obtainable by superimposing the two wheels
- Gobo change with music sync and/or blackout
- 2 rotary prisms with adjustable speed in both directions
- 1 variable filter frost
- 1 frost filter with adjustable beam
- 1 3,200°K color conversion filter (full CTO)
- 1 half CTO conversion filter

Movement

- 540° Pan (3.8 sec.) and 270° Tilt (2.4 sec.)
- 8/16 bit movement resolution
- Automatic repositioning in the event of accidental head movement
- invertible Pan/Tilt movement
- Adjustable Pan/Tilt offset
- Adjustable acceleration and speed parameters

Electronic Ballast

Supplied as standard with every fixture

- Automatic universal 90/245V 50/60Hz power supply
- Flicker-free
- Reduction of lamp power in the event of fixture overheating
- Power Factor Correction
- Automatic energy saving if the beam is blacked out
- Automatic lamp re-strike

Optics

- High luminous efficiency optics
- 4 beam angles - 9°, 12°, 15° and 18°

Display/Microcomputer

- Personalization of the fixture according to installations: test functions for all effects; enabling of remote lamp On/Off via DMX; enabling of fixture reset via DMX; fixture addressing; display "flip" function (rotation through 180°); dimmable display, and more: Display of data such as: lamp elapsed time and number of strikes, fixture operating time, software version supported.

Control signal

Input signal DMX 512 – RS 232

Clamping system

- "Fast-Lock" clamp supplied as standard
- Several mounting points for clamps, enabling the fixture to be mounted on any type of truss
- Connection point for safety cable



Accessories

- Light Dome for outdoor protection cod: 0202406
- Single flight case cod: 0061741
- Double flight case cod: 0061744
- Optional clamp unit cod: 0202403

Technical specifications

LAMP:

MSR 1200SA GY16 -
COLOR TEMPERATURE: 6500K
LIGHT OUTPUT: 96000 LUMEN
LIFE: 500 HOURS

POWER SUPPLY:

ELECTRONICS AND LAMP ARE POWERED BY A SWITCHING POWER SUPPLY. THE FIXTURE CAN OPERATE AT ANY VOLTAGE BETWEEN 90V AND 240V 50Hz, 60Hz.

POWER ABSORBED:

1500W

OPTICAL SYSTEM: I

INTERNAL OPTICAL GROUP COMPRISING HIGH LUMINOUS EFFICIENCY POLISHED REFLECTOR AND DOUBLE CONDENSER; 4 BEAM ANGLES: 9° - 12° - 15° - 18°; ELECTRONIC FOCUS.

ELECTRONICS:

CS0276 (INPUT SIGNAL); CS0244 + CS0245 (ELECTRONIC BALLAST); CS 0252 (IGNITOR); CS 0268 (ELECTRONICS AND-MOTOR DRIVER CONTROL) CS0273(PAN/TILT MOTOR DRIVER CONTROL)

SETTING:

VIA BUILT-IN MICROCOMPUTER

CONTROL SIGNAL:

USITT DMX 512 OR RS-232

DMX CONTROL CHANNELS:

18 CH

AUTOMATIC REPOSITIONING:

VIA OPTICAL SENSORS CONSTANTLY CONTROLLING PAN AND TILT POSITION AND CORRECTING IT IN THE EVENT OF THE MOVING HEAD BEING ACCIDENTALLY MOVED.

COOLING:

FORCED VENTILATION BY MEANS OF TWO LOW-NOISE FANS WHOSE SPEED IS ELECTRONICALLY CONTROLLED ACCORDING TO CHANGES IN TEMPERATURE IN THE FIXTURE.

PROTECTION FUSES:

2x16A CF 6.3 x 32 TYPE FUSES

BODY:

SHEET METAL WITH POWDER PAINT FINISH AND EXTRUDED/DIE-CAST ALUMINIUM WITH POWDER PAINT FINISH.

DIMENSIONS:

(HxLxD) 77x53x47.5

WEIGHT:

Kg 30

SGM Elettronica reserves the right to improve or modify their products at any time without prior notice.

Always consult the handbook of the unit being used to avoid errors and differences between the actual functions and those shown in the book.

1 - installation

Before proceeding with fixture installation, make certain that the packing contains all the items shown in the following list and ensure that the fixture is undamaged.

If in doubt, don't use the fixture and contact an authorized SGM technical assistance centre and the freight company.

In fact, only the recipient can claim for any damage caused to the fixture during transport.

- Giotto spot 1200
- Warranty
- Instruction Manual
- 1 Male XLR 5 P connector
- 1 Female XLR 5 P connector
- 1 Power-con connector
- 2 Fast-Lock clamps

KEEP THE PACKING MATERIAL. Packing material (plastic bags, polystyrene foam, nails, etc.) is potentially hazardous, so must never be left within children's reach. Use the original packing in the event of having to return the fixture to the manufacturer for repair or maintenance: it's been designed specifically to protect the fixture during transport.

1.1- Locking and unlocking the mechanism

Giotto fixtures are fitted with a mechanical locking system for the moving parts.

The moving head and yoke must be locked every time the fixture is transported, using the appropriate flightcase or the original packing, which have an suitable shock-proof support system.

Remember to ALWAYS unlock the mechanism BEFORE switching on the fixture!!!

The fixture is locked and unlocked by turning the two knobs on the yoke, following the printed indications

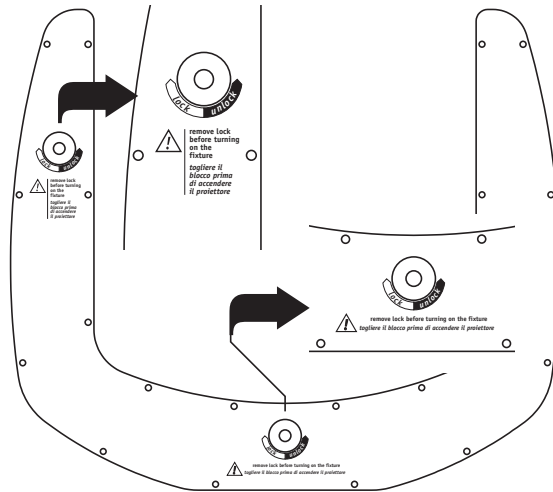

DANGER! high temperature - avoid contact with persons and things.

1.2 - Access to the inside

Giotto fixtures have a simple mechanism for opening the moving head.

To open the two covers, just turn the two locking screws shown in the illustration through 180°, then raise the cover.

Any work must ALWAYS be carried out by qualified technical personnel.

When work is finished, close the covers again, making certain that they are closed against the fixture body.

ATTENTION: make sure that the fixture is off and the temperature of the parts can't cause burns (wait for at least 30 minutes after switching off).

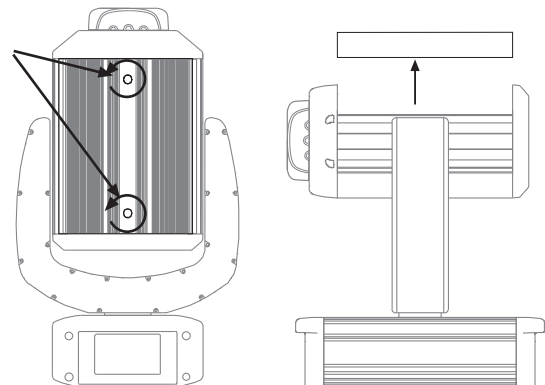

1.3 - Lamp installation



ATTENTION! This fixture is designed exclusively for use with Philips MSR 1200SA lamps. NEVER USE ANY OTHER TYPES OF LAMPS.

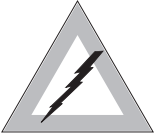

- Disconnect the power supply before carrying out any work on the fixture.
- Make certain that the fixture is off and the temperature of the components can't cause burns (wait at least 20 minutes after switching off).



- Never carry out any work if the fixture doesn't have its protective covers or its lenses are damaged. Discharge lamps can explode.
- Never look directly at the lamp when it's lit - discharge lamps emit UV rays which are dangerous for sight.

There's an optical group in the fixture's moving head. Follow these instructions when fitting or replacing the lamp.

1. Disconnect the power supply and wear protective gloves and glasses.
2. Remove the head's top cover
3. **(fig.1)** Unscrew the two locking screws (A) on the aluminium support which fix the lampholder base to the optical group
4. **(fig.2)** Raise the aluminium support and fit the lamp in the base. Avoid touching the lamp bulb with your fingers. Should this happen, clean it before use with a soft cloth and alcohol, then clean with a dry cloth.
5. **(fig.3)** Tighten the screws again, making certain that the lamp wires are positioned in the appropriate slots.
6. Close the cover again.

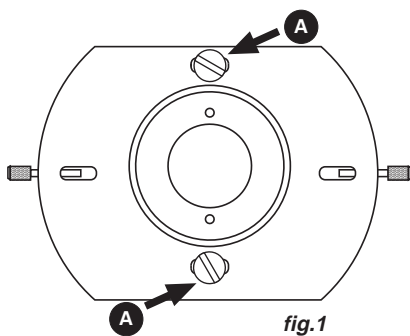

fig.1

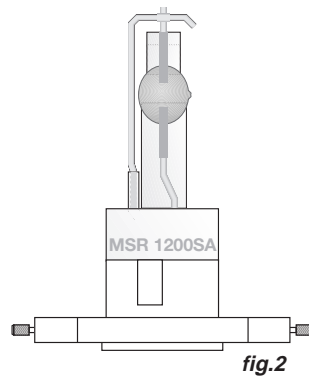

fig.2

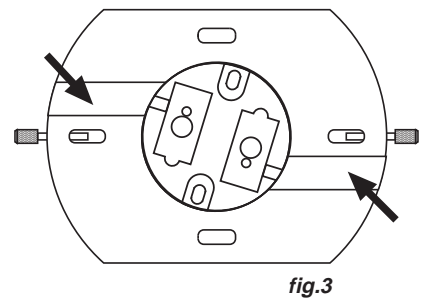

fig.3

1.4 - Lamp Alignment

After each relamping, it's important to align the lamp with the optical group in order to obtain maximum uniformity and light output.

1. Fit the new lamp, close the fixture and switch it on.
2. Connect the fixture to a lighting console.
3. Point the fixture at a flat surface (if possible light coloured) at a distance of at least 3metres.
4. Set the control channels in such a way as to obtain the projection of a white beam. Then: IRIS open, DIMMER at maximum luminosity, suitable FOCUS, no GOBO or COLOR projected.
5. **(Fig.4)** Loosen the two fastening screws (A) and use the knobs on the sides to align the lamp horizontally.
6. **(Fig.5)** Use the large centre brass ferrule to align the lamp vertically with respect to the optical group.
7. The lamp is aligned correctly when a uniform beam is obtained, without any shadows or zones which are brighter than others.
8. **(Fig.6)** Tighten the fastening screws and close the cover again

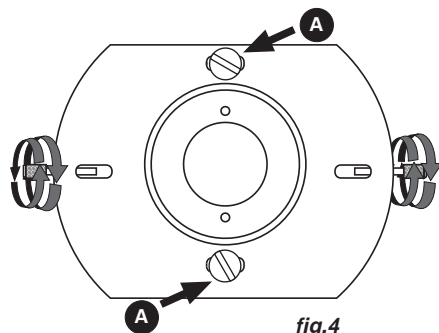

fig.4

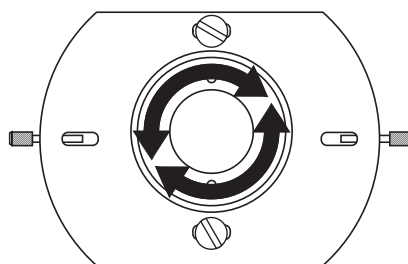

fig.5

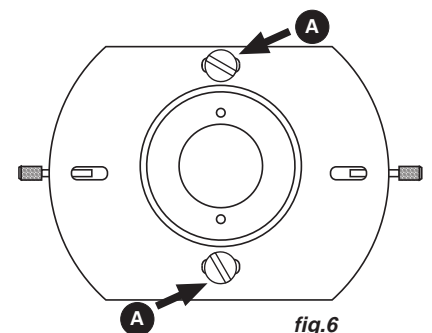

fig.6

1.5-Power cable construction



DANGER! ELECTRICAL SHOCK HAZARD

- **Electrical work necessary for installing the fixture must be carried out by a qualified electrician or an experienced person.**
- **The fixture must be suitably earthed. Failure to comply with this automatically invalidates the guarantee.**

The POWER-CON type connector supplied along with the Giotto is indispensable for connecting the fixture to the power supply. The following design shows how to connect the connector to the cable, whereas the table shows the symbols normally used to indicate connections.

When in doubt, consult a qualified electrician.

CABLES	PIN	TYPICAL	US	UK
Brown	Phase	"L"	Yellow/Copper	Red
Blue	Neutral	"N"	Silver	Black
Yellow/Green	Ground		Green	Green

Conductors' cross-section

Power supply	Minimum cross-section
230 V	3x1,5
120 V	3x2,5

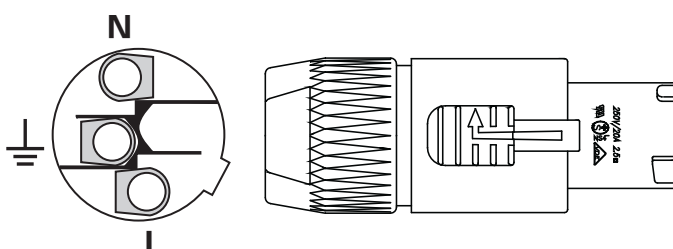

1.6 - Giotto Spot's power supply



ATTENTION!!

- Don't power the Giotto with a dimmer circuit - this could damage the electronic ballast.
- Before connecting the fixture, make certain that the data on the fixture's plate correspond with those of the local main power supply.
- The fixture must be connected to a cut-off circuit with the following characteristics:

Cut-off circuit

Power supply	in	id
230 V	16A	0,03A
120 V	32A	0,03A

1.7- Installing the fixture on a support structure

Read the following safety information before proceeding with the installation of the fixture:

- Fixture not for domestic use.
- Do not install the fixture near sources of heat.
- Install the fixture in a well ventilated place.
- Avoid blocking air intakes and outputs.
- Do not use the fixture:
 - In places subject to vibrations or bumps
 - In places with excessive humidity
 - In places subject to temperatures of more than 45° or less than 2°C
- Protect the fixture from excessive humidity (ideal values are between 35 and 1'80%).
- Avoid inflammable liquids, water or metallic objects entering the fixture .
- Keep any inflammable material at a distance of at least 1.5m from the fixture.
- Position the fixture at least 1.5m. from the surface to be lit.
- Don't lift the fixture holding it by the moving part (the head).

1.8 - Positioning the fixture

Can be installed in any position.

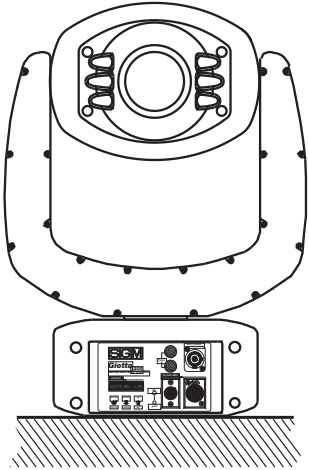

OK

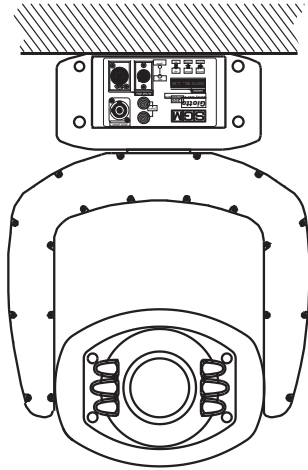

OK

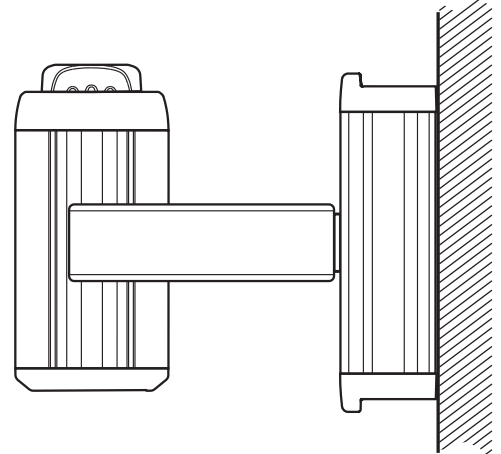

OK

1.9 - Fitting clamps

- Always use two clamps to hang the fixture.
- Fix the fixture to the support structure using safety chains fitted to the 2 holes on the underside of the fixture's base.
- Don't fix the safety chain to the handles.
- Remember to unlock the PAN and TILT locking system once the fixture is mounted on the support structure.

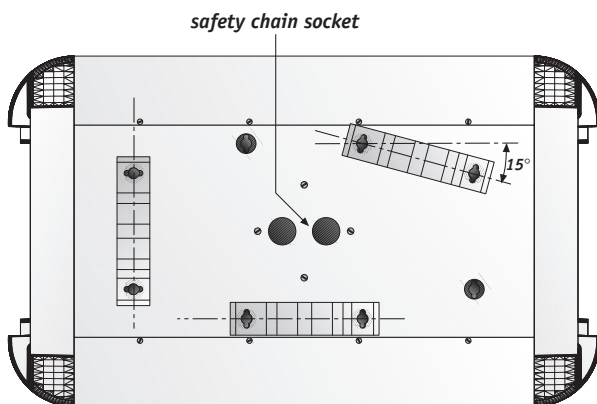

2.0-Construction of the signal cable

Giotto 1200 has a DMX 512 input fitted with standard 5-pin XLR connectors. Screened cables in compliance with EIA RS-485 specifications and the following characteristics must be used for connections:

- 2 conductors plus screen
- 120Ohm impedance
- low capacitance
- max. transmission rate 250kbaud.

Cable connections:

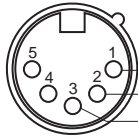

COMMON
DMX-
DMX+

see illustration, taking care with the screen, which must be connected to Pin 1



ATTENTION: the screened parts of the cable (sleeve) must NEVER be connected to the system's earth, as this would cause faulty fixture and controller operation.

Example of connection of the DMX line

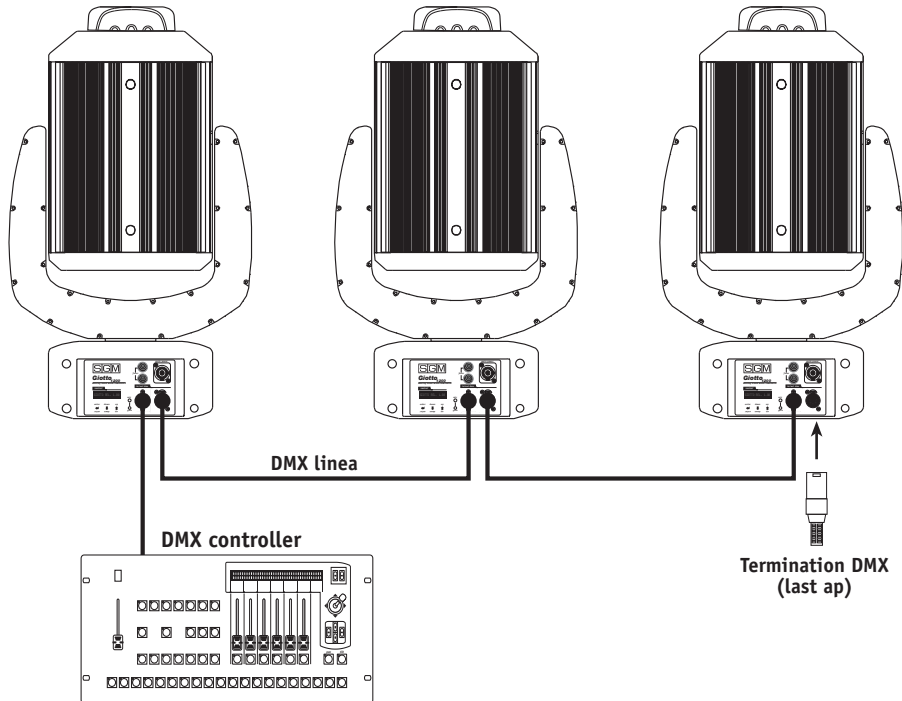

To avoid the risk of faulty operation, follow these indications:

Maximum cable length: 500 metres

Max. N° of fixtures connected: 32

Cable runs: Avoid running cables alongside power supply lines.

Termination: A 120Ohm resistor between Pins 2 and 3 on the last fixture.

2.1- Construction of the DMX termination

The termination avoids the risk of DMX 512 signals being reflected back along the cable when they reaches the end of the line: under certain conditions and with certain cable lengths, this could cause them to cancel the original signals. The termination is prepared by soldering a 120Ohm 1/4 W resistor between pins 2 and 3 of the 5-pin male XLR connector (see diagram).

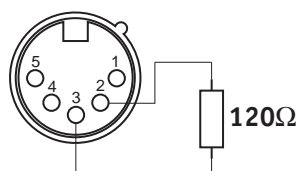

2.2-RS232 connection

For this connection, use good quality screened coax cable (RG58 50Ohms) to avoid problems with signal transmission and faulty fixture operation.

Connectors must always be 5-pin XLRs. Refer to the diagram for wiring.

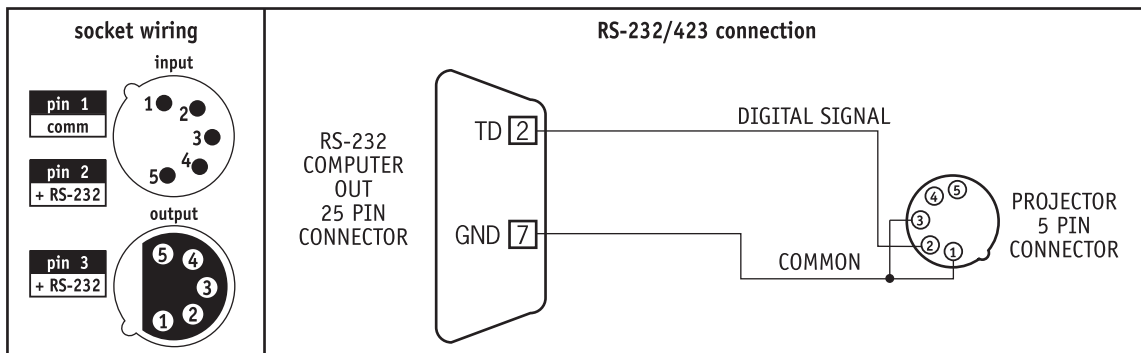

3.0 - "Control" microcomputer

Giotto Spot 1200 is equipped with a microcomputer which allows to customize the fixture to suite the type of installation. In fact, it's possible to assign the start address; obtain information regarding lamp life and fixture operation time; run test programs to check correct fixture operation and customize some parameters.

3.1- Navigating in the menu

When it's switched on, the fixture runs a start-up reset procedure and the display indicates if there's an input signal or not.

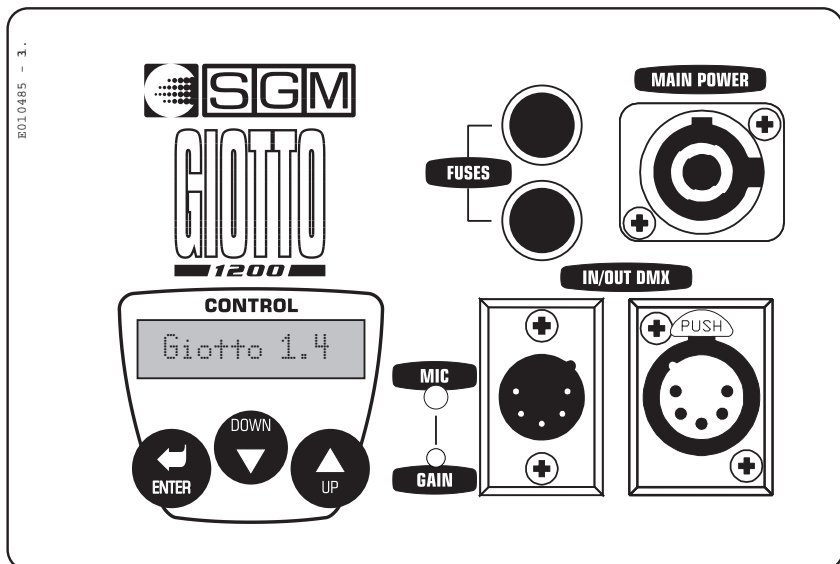

The 3 keys under the display are for selecting and using the various submenus which make up the main menu.

- **UP/DOWN** keys: used to scroll the various items in the menu. In the selected menu, used to change the required parameters.
- **ENTER** key: used to access to the selected menu and, once the necessary changes have been made, is used to confirm them.

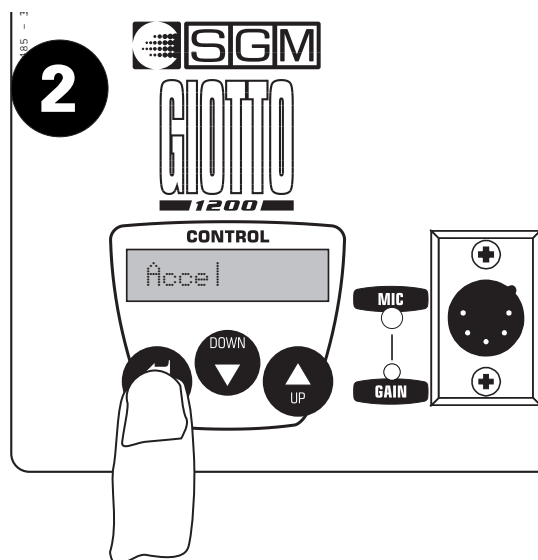
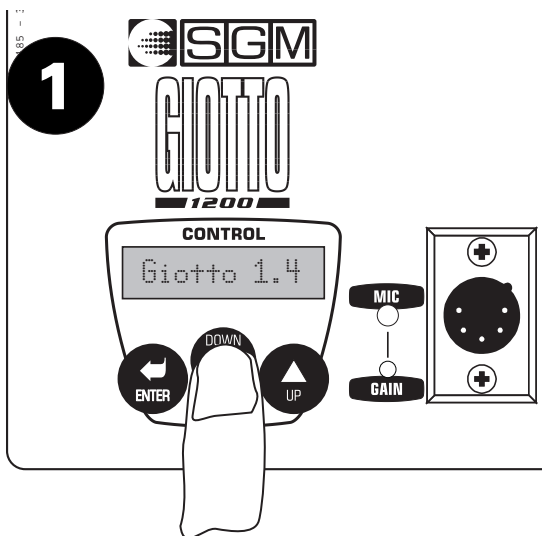

Menu	Options	Description (Default configurations are shown in bold text)
Addr=xxx	Range 001-487	Addressing the fixture
Pmove	NORM	Normal control of Pan from left to right
	REV	Control of Pan inverted - from right to left.
PP_min	Range 000-540	Sets Pan starting angle. Default Configuration = 000 degrees
PP_max	Range 000-540	Range 000-540 Sets Pan ending angle. Default Configuration = 000 degrees
Tmove	NORM	Normal control of Tilt from up to down.
	REV	Control of Tilt inverted, from bottom to top.
TP_min	Range 000-270	Range 000-270 Set Tilt starting angle. Default Configuration = 000 degrees
TP_max	Range 000-270	Range 000-270 Sets Tilt ending angle Default Configuration = 000 degrees
Swap	ON	Pan is controlled by Tilt commands and vice versa
	OFF	Normal control of Pan and Tilt
Lmp_H		Read-only menu. Records the elapsed time of the lamp. Can be reset.
Lmp_st		Read-only menu. Records the number of lamp strikes. Can be reset.
SCN_h		Read-only menu. Records total fixture operating time.
SIGN	DMX	Signal DMX selected
	RS-232	Signal RS-232 selected
SMD	16 bit	Allows to select movement resolution. Default configuration = 16-bit
	8 bit	
LMP_ctr	EN	Remote control of lamp ignition enabled.
	DS	Remote control of lamp ignition disabled.
RST_ctr	EN	Remote control of reset enabled.
	DS	Remote control of reset disabled.
Speed	100% - 92% 84% - 76%	Possibility of slowing the maximum speed of PAN and TILT movement. Default configuration = 100%
Accel	Fast	Optimizes speed performance.
	Slow	Optimizes performance for the smooth movement
Bright	100-53-40-27-20-13-6-0 (%)	Allows to regulate the brightness of the display. Default configuration=40%
DspIFlip		Inverts the reading position of the display. Used according to the position of the fixture.
DMXdly	Range 8-998 sec	It's possible to decide for how many seconds the fixture's last operating status must be held when there's no DMX signal (default =20sec.).
UNL		it maintains always the last condition of job independently from how much time lacks the dmx
SLLF	ON	Energy saving enabled
	OFF	Energy saving disabled
TEST		
Reserved		
Giotto 1.4		Read-only menu giving information on the software version supported by the fixture.

3.2 - Allocating the first addressed channel

In order to receive the commands necessary to operate from a lighting console, each fixture has to be allocated a start address. This address normally indicates the first channel used (start channel) and can be allocated following a different criterion from that used to connect the signal line. Giotto Spot uses 18 controls channels, so during allocation, this quantity must be borne in mind to avoid possible overlapping of other fixtures' channels, which would cause problems with the perfect control of all the available functions. Should it be necessary, it's possible to allocate the same start channel to several fixtures, in this case the fixtures will all follow the same commands, but can't be controlled separately.

To address fixtures correctly, proceed as follows:

1. Connect Giotto Spot to the power supply, wait until it has completed reset operations and "DMX signal" appears on the display.
2. Use the **UP/DOWN** keys to find the "Addr" menu
3. Press **ENTER** to confirm. The message on the display starts to flash.
4. Use the **UP/DOWN** keys to select the channel required.
5. Press **ENTER** to confirm.

Fixture N.	Start Address	Fixture N.	Start Address	Fixture N.	Start Address	Fixture N.	Start Address
1	001	8	127	15	253	22	379
2	019	9	145	16	271	23	397
3	037	10	163	17	289	24	415
4	055	11	181	18	307	25	433
5	073	12	199	19	325	26	451
6	091	13	217	20	343	27	469
7	109	14	235	21	361	28	487

3.3 - Direction of Pan movement

This function allows to decide the direction in which the Giotto's moving head pans, indispensable when several fixtures are installed in order that fixtures installed opposite each other move in the same direction when they receive a command.

To modify Pan movement, proceed as follows:

1. Connect the Giotto Spot to the power supply, wait till it has completed reset operations and "DMX signal" appears on the display.
2. Use the UP/DOWN keys to find the "Pmove" menu
3. Press ENTER to confirm. The message on the display will start to flash.
4. Use the UP/DOWN keys to select which of the two available options is required (see table pag.15).
5. Press ENTER to confirm.

3.31 - Setting Pan starting angle

The Giotto fixture has a Pan movement range of 540° (a revolution and a half). If the entire excursion doesn't have to be used, two parameters allow to set the starting angle (PP_min) and ending angle (PP_max). The only limit is the minimum difference between starting (MIN) and ending angle (MAX), which is 4°.

To limit Pan movement, proceed as follows:

1. Connect Giotto Spot to the power supply, wait till it has completed reset operations and "DMX signal" appears on the display.
2. Use the UP/DOWN keys to find the "PP_min" menu if the starting angle has to be modified. If the ending angle has to be modified, find the "PP_max" menu.
3. Press ENTER to confirm. The message on the display will start to flash.
4. Use the UP/DOWN keys to select the new starting (or ending) angle.
5. Press ENTER to confirm.

3.4 - Direction of Tilt movement

This function allows to decide the direction in which the Giotto's moving head tilts, indispensable when several fixtures are installed in order that fixtures installed opposite each other move in the same direction when they receive a command.

To modify Tilt movement, proceed as follows

1. Connect Giotto Spot to the power supply, wait till it has completed reset operations and "DMX signal" appears on the display.
2. Use the UP/DOWN keys to find the "Tmove" menu
3. Press ENTER to confirm. The message on the display will start to flash.
4. Use the UP/DOWN keys to select which of the two available options is required (see table pag.15).
5. Press ENTER to confirm.

3.41-Limiting Tilt movement

The Giotto fixture has a Tilt movement range of 270° (3/4 of a revolution). If the entire excursion doesn't have to be used, two parameters allow to limit the starting angle (TP_min) and ending angle (TP_max). The only limit is the minimum difference between starting (MIN) and ending (MAX), which is 4°.

To limit the Tilt movement, proceed as follows:

1. Connect Giotto Spot to the power supply, wait till it has completed reset operations and "DMX signal" appears on the display.
2. Use the UP/DOWN keys to find the "TP_min" menu if the starting angle is to be modified. If the ending angle is to be changed, find the "TP_max" menu.
3. Press ENTER to confirm. The message on the display will start to flash.
4. Use the UP/DOWN keys to select the new starting (or ending) angle.
5. Press ENTER to confirm.

3.5 - Pan/Tilt inversion

This function also allows to optimize the movement of the Giotto's moving head in relation to the operator's position, in order to simplify all positioning procedure.

When SWAP is enabled (ON), this means that the lighting console sends the data regarding Pan to the Tilt controls and vice versa.

To invert PAN and TILT movement, proceed as follows:

1. Connect Giotto Spot to the power supply, wait till it has completed reset operations and "DMX signal" appears on the display.
2. Use the UP/DOWN keys to find the "SWAP" menu.
3. Press ENTER to confirm. The message on the display will start to flash.
4. Use the UP/DOWN keys to select which of the two available options is required (see table pag.15)
5. Press ENTER to confirm.

3.6 - Lamp elapsed time meter

The Giotto microcomputer stores various data, including that relative to the number of hours the lamp is lit (elapsed time). This is necessary to know in advance when it's almost time for relamping: lamp life is approximately 750 hours.

To see how many hours a lamp has been used, proceed as follows:

1. Connect Giotto Spot to the power supply, wait till it has completed reset operations and "DMX signal" appears on the display.
2. Use the UP/DOWN keys to find the ""Lmp_H" menu. The total number of hours the lamp has been lit will be displayed automatically.

3.61 - Resetting the lamp elapsed time meter

Each time a new lamp is fitted, it's possible to reset the meter indicating the elapsed time in order to have the real elapsed time for the lamp about to be fitted.

To reset the elapsed time meter, proceed as follows:

1. Connect Giotto Spot to the power supply, wait till it has completed reset operations and "DMX signal" appears on the display.
2. Use the UP/DOWN keys to find the ""Lmp_H" menu.
3. Press ENTER to confirm. The message on the display will start to flash.
4. The DOWN key can be used to reset the meter.
5. On the contrary, pressing the UP key restores the previous value.
6. Press ENTER to confirm the changes.

3.7 - Lamp strike meter

The Giotto's microcomputer stores various data, including those relative to the number of lamp strikes. This information is important because needless lamp strikes causes stress to materials and components, so can contribute to reducing lamp life.

To know how many times a lamp has been ignited:

1. Connect Giotto Spot to the power supply, wait till it has completed reset operations and "DMX signal" appears on the display.
2. Use the UP/DOWN keys to find the ""Lmp_st" menu. The number of lamp strikes will be displayed automatically.

3.71- Resetting the lamp strike meter

Each time the fixture is relamped, it's possible to reset the meter which counts the strikes, in order to have number of actual strikes for the lamp about to be installed.

To reset the meter, proceed as follows:

1. Connect Giotto Spot to the power supply, wait till it has completed reset operations and "DMX signal" appears on the display.
2. Use the UP/DOWN keys to find the ""Lmp_st" menu.
3. Press ENTER to confirm. The message on the display will start to flash.
4. The DOWN key can be used to reset the meter.
5. On the contrary, pressing the UP key restores the previous value.
6. Press ENTER to confirm the modifications.

3.8 - Fixture operating time meter

This function allows to see for how many hours the fixture has been operating. This meter cannot be reset. To see for how many hours the fixture has been used, proceed as follows:

1. Connect Giotto Spot to the power supply, wait till it has completed reset operations and "DMX signal" appears on the display.
2. Use the UP/DOWN keys to find the "Scn_H" menu. The number of fixture operating hours will be displayed automatically.

3.9 - Input signal

This function allows to choose the type of input signal to be used: DMX 512 or RS-232.

To select the required signal, proceed as follows:

1. Connect Giotto Spot to the power supply, wait till it has completed reset operations and "DMX signal" appears on the display.
2. Use the UP/DOWN keys to find the "Sign=DMX" menu.
3. Press ENTER to confirm. The message on the display will start to flash.
4. Use the UP/DOWN keys to select the type of signal to be used.
5. Press ENTER to confirm the changes.

3.10 - Pan/ Tilt movement resolution

This function allows to define the movement resolution (16 or 8 bit). The difference is in the number of steps in which the range of head movement is divided.

In 16-bit mode, 540° of Pan and 270° of Tilt are divided into 65,536 steps, ensuring very smooth precision even at very low speeds. In 8-bit mode, the number of steps is 256, which nevertheless allow precise movements.

1. Connect Giotto Spot to the power supply, wait till it has completed reset operations and "DMX signal" appears on the display.
2. Use the UP/DOWN keys to find the "SMD" menu.
3. Press ENTER to confirm. The message on the display will start to flash.
4. Use the UP/DOWN keys to select the type of resolution required.
5. Press ENTER to confirm the modifications.

3.11- Remote control of lamp ignition

Operators can decide if the ignition of the Giotto's lamp is to be controlled from a lighting console or be automatic.

To access this function, proceed as follows:

1. Connect Giotto Spot to the power supply, wait till it has completed reset operations and "DMX signal" appears on the display.
2. Use the UP/DOWN keys to find the "LMP_ctr" menu.
3. Press ENTER to confirm. The message on the display will start to flash.
4. Use the UP/DOWN keys to select the required option.
5. Press ENTER to confirm the modifications.

3.12 - Remote control of fixture reset

Using this menu, it's possible to decide whether to reset the fixture via remote control or not.

To enable this function , proceed as follows:

1. Connect Giotto Spot to the power supply, wait till it has completed reset operations and "DMX signal" appears on the display.
2. Use the UP/DOWN keys to find the "RST_ctr" menu.
3. Press ENTER to confirm. The message on the display will start to flash.
4. Use the UP/DOWN keys to select the required option.
5. Press ENTER to confirm the changes.

3.13 - Display brightness

Operators can select one of the brightness levels available for the Giotto display, which can be standard or very low. This option is intended for theatre and television use, where excessive brightness can be troublesome.

To change display brightness, proceed as follows:

1. Connect Giotto Spot to the power supply, wait till it has completed reset operations and "DMX signal" appears on the display.
2. Use the UP/DOWN keys to find the "Bright" menu.
3. Press ENTER to confirm. The message on the display will start to flash.
4. Use the UP/DOWN keys to select the required option from those available.
5. Press ENTER to confirm the modifications.

3.14 - Display reading position

When the fixture is mounted "upside down" on a structure, operators can turn the display through 180°, thus greatly facilitating the reading of the menus on the display.

To change the reading position, proceed as follows:

1. Connect Giotto Spot to the power supply, wait till it has completed reset operations and "DMX signal" appears on the display.
2. Use the UP/DOWN keys to find the "Dspl Flip" menu
3. Press ENTER to confirm. The message on the display will start to flash.
4. Use the UP/DOWN keys to select the required option.
5. Press ENTER to confirm the modifications.

3.15 - Test functions

Test programs can be used in the event of it being necessary to check the correct operation of the fixture or some of its parts.

To selection the required test program, proceed as follows:

1. Connect Giotto Spot to the power supply, wait till it has completed reset operations and "DMX signal" appears on the display.
2. Use the UP/DOWN keys to find the "Test" menu.
3. Press ENTER and hold it down for a few seconds to confirm. The message on the display will start to flash.
4. Use the UP/DOWN keys to select the program corresponding to the part of the fixture to be tested.
5. Press ENTER to run the test program.
6. To quit the test functions, press ENTER once, then press it again for a few seconds until "Test" re-appears on the display.

3.16-Control of the acceleration of movement speed

Movement can be optimized by changing the speed (SPEED) and acceleration (ACCEL) parameters, obtaining smooth fast or slow movements as required.

To optimize movement, proceed as follows:

1. Connect Giotto Spot to the power supply, wait till it has completed reset operations and "DMX signal" appears on the display.
2. Use the UP/DOWN keys to find the "Speed" or "Accel" menu.
3. Press ENTER to confirm. The message on the display will start to flash.
4. Use the UP/DOWN keys to select the required option.
5. Press ENTER to confirm the changes.

3.17-dmx dly

This allows to set the for how many seconds the fixture's last operating settings are maintained should there be no DMX signal.

This function is indispensable in those cases in which there is an accidental DMX failure.

To set the required time, proceed as follows:

1. Connect Giotto Spot to the power supply, wait till it has completed reset operations and "DMX signal" appears on the display.
2. Use the UP/DOWN to find the "DMXDLY" menu.
3. Press ENTER to confirm. The message on the display will start to flash.
4. Use the UP/DOWN keys to select the required time.
5. Press ENTER to confirm changes.

3.18 - SLLF

This is an energy-saving function. If the function is enabled (SLLF=ON), the fixture reduces lamp power by dimming it electronically after the shutter has been closed for 30 seconds.

Maximum power will automatically be restored as soon as the shutter is reopened.

To enable this function, proceed as follows:

1. Connect Giotto Spot to the power supply, wait till it has completed reset operations and "DMX signal" appears on the display.
2. Use the UP/DOWN keys to find the "SLLF" menu.
3. Press "Enter" to confirm. The message on the display will start to flash.
4. Use the UP/DOWN keys to select the required option.
5. Press "Enter" to confirm changes.

3.19 - Reserved functions

Some fixture functions can't be accessed by operators as they regard software sections as yet to be defined in this firmware release. When RESERVED appears on the display, you're in this section. Access is forbidden.

4.0 - GIOTTO SPOT 1200 CONTROL CHANNELS

DMX Channel	Functions	Description	
Ch1	Pan MSB	Pan High byte in 8-bit operation Only this byte is sent	
Ch2	Pan LSB	Pan Low byte for 16-bit positioning	
Ch3	Tilt MSB	Tilt High byte in 8-bit Operation Only this byte is sent	
Ch4	Tilt LSB	Tilt Low byte for 16-bit positioning	
Ch5	Iris	Iris aperture control	Linear range 0 – 255
Ch6	Color	24 combinations of color + rainbow + music change	See table
Ch7	Gobos	2 4-position wheel for 25 combination, gobo wheel rotation, music change	See table
Ch8	Shutter/ Strobe	Shutter and strobe with music sync Black –out gobo and colour change	See table
Ch9	Dimmer	The dimmer is partially electronic and partially mechanical	Linear range 0 – 255
Ch10	Rotation Gobos	Indexed position and rotation in both directions at adjustable speed See table	See table
Ch11	Prisms	Allows to insert one of the two rotary prisms or neither See table	See table
Ch12	Rotation Prisms	Control of the prisms' rotation speed in one direction or the other See table	See table
Ch13	Electronic Focus	Allows to focus the image Linear range	Linear range 0 - 255
Ch14	Lenses	Allows to insert lenses for obtaining 4 beam angles See table	See table
Ch15	Filters	Conversion filters + Effects See table	See table
Ch16	Frost	Variable frost filter Range 0 - 255	Range 0 - 255
Ch17	Mspeed	Movement speed Controlled cross-fade Slowest vel. min Fastest vel.max	See table
Ch18	Reset/Lamp		See table

5.0-IRIS CHANNEL - CH 5-

Adjustable by channel 5, it allows the linear regulation of amplitude of the luminous bundle beam.
Peculiar characteristics of the diaphragm are the high speed of opening / closing (100 mS) and low noise.

DMX512 Level range 0-- 255	FUNCTION
0	MINIMAL OPENING
000-255	LINEAR REGULATION
255	MAXIMUM OPENING

6.0 - COLOR CHANNEL - CH 6-

Giotto Spot 1200 is fitted with an exclusive color generation system comprising 12 frames containing dichroic colour filters. Color changes are controlled by Channel 6, allowing to select 24 different colors which, combined with the two colour conversion filters, produce 72 different tones. As well as selecting the colour, it's also possible to use some functions with great visual impact, such as running the colourchanger in sync with the music or continuous rotation of all the colours available at 3 different speeds (rainbow effect). By using the colour channel in combination with the strobe channel, an "autoshade" effect can be obtained, which blacks out projection for a moment when colours are changed.

DMX VALUE	CENTRAL VALUE	FUNCTION
0 - 7	3	WHITE
8 - 14	11	PINK
15 - 21	18	MAGENTA
22 - 28	25	LAVENDER
29 - 35	32	BLU LIGHT
36 - 42	39	AZURE
42 - 49	46	CYAN
50 - 56	53	YELLOW
57 - 63	60	AMBER
64 - 70	67	FLAME RED
71 - 77	74	WOOD
78 - 84	81	PRIMARY RED
85 - 91	88	LIGHT GREEN
92 - 98	95	GREEN AZURE
99 - 105	102	GREEN AMBER
106 - 112	109	YELLOW GREEN
113 - 119	116	GREEN CYAN
120 - 126	123	GREEN YELLOW
127 - 133	130	DARK RED
134 - 140	137	LIGHT MEDIUM BLUE
141 - 147	144	GREEN
148 - 154	151	MEDIUM BLUE
155 - 161	158	MEDIUM RED
162 - 168	165	ORANGE
169 - 175	172	DARK PURPLE
176 - 182	179	RAINBOW SPEED 1 SLOW
186 - 189	186	RAINBOW SPEED 2
190 - 196	193	RAINBOW SPEED 3
197 - 203	200	RAINBOW SPEED 4 FAST
204 - 210	207	MUSIC CHANGE AT EACH BASS BEAT
211 - 217	214	MUSIC CHANGE EVERY TWO 2 BASS BEATS
218 - 224	221	MUSIC CHANGE EVERY 3 BASS BEATS
225 - 255	236	MUSIC CHANGE EVERY 4 BASS BEATS

7.0- GOBO CHANNEL - CH 7

Gobo selection is controlled by Channel 7. The gobo group comprises two independent wheels, each with four images and a blank position.

The gobos are interchangeable and superimposing the two wheels enables 25 different combinations to be obtained. Changeover from one gobo to another can be done rapidly and directly, or blacked out: this function is controlled by channel 8 (shutter/strobe) using the strobe/shutter's "Autoshade on Gobo" function. It's also possible to synchronize gobo changes with a musical bass beat, in which case, gobo selection is random and in any case not synchronized on the various fixtures.

The gobos on the rotary wheel can rotate both clockwise and counterclockwise and the position can be stored if required.

DMX VALUE	CENTRAL VALUE	FUNCTION
0 -- 8	4	WHITE - A WHITE - B
9 -- 17	13	WHITE - A WHITE 1B
18 -- 26	22	WHITE - A GOBO 2B
27 -- 35	31	WHITE - A GOBO 3B
36 -- 44	40	WHITE - A GOBO 4B
45 -- 53	49	GOBO - 4B WHITE - B
54 -- 62	58	GOBO - 3B WHITE - B
63 -- 71	67	GOBO - 2B WHITE - B
72 -- 80	76	GOBO - 1B WHITE - B
81 -- 89	85	GOBO - 1A GOBO - 1B
90 -- 98	94	GOBO - 2A GOBO - 1B
99 -- 107	103	GOBO - 3A GOBO - 1B
108 -- 116	112	GOBO - 4A GOBO - 1B
117 -- 125	121	GOBO - 4A GOBO - 2B
126 -- 134	130	GOBO - 3A GOBO - 2B
135 -- 143	139	GOBO - 2A GOBO - 2B
144 -- 152	148	GOBO - 1A GOBO - 2B
153 -- 161	157	GOBO - 1A GOBO - 3B
162 -- 170	166	GOBO - 2A GOBO - 3B
171 -- 179	175	GOBO - 3A GOBO - 3B
180 -- 188	184	GOBO - 4A GOBO - 3B
189 -- 197	193	GOBO - 4A GOBO - 4B
198 -- 206	202	GOBO - 3A GOBO - 4B
207 -- 215	211	GOBO - 2A GOBO - 4B
216 -- 225	220	GOBO - 1A GOBO - 4B
226 -- 232	230	RAINBOW A SPEED 1
233 -- 240	237	RAINBOW A SPEED 2
241 -- 248	245	RAINBOW A SPEED 3
249 -- 255	253	MUSIC CHANGE GOBOS

8.0-CHANNEL SHUTTER/ STROBE CH - 8

The Shutter/Strobe is controlled by Channel 8. The mechanism which enables the strobe effect to be generated is the same as that used for dimming the light beam, however it's also possible to control the light's intensity while the strobe's enabled. This ensures instant beam blackout without any light spill.

High-impact visual effects, such as the strobe effect running in sync with the bass beat and the light blackout during color and gobo changes can be enabled directly with this channel.

DMX VALUE	CENTRAL VALUE	FUNCTION
0 – 7	4	Closed
8 – 15	12	Strobe at a frequency of 1 Hz
16 – 23	20	Strobe at a frequency of 1,38 Hz
24 – 31	28	Strobe at a frequency of 1,6 Hz
32 – 39	36	Strobe at a frequency of 1,9 Hz
40 – 47	44	Strobe at a frequency of 2,3 Hz
48 – 55	52	Strobe at a frequency of 2,7 Hz
56 – 63	60	Strobe at a frequency of 3,4 Hz
64 – 71	68	Strobe at a frequency of 4 Hz
72 – 79	76	Strobe at a frequency of di 5 Hz
80 – 87	84	Strobe at a frequency of 6 Hz
88 – 95	92	Strobe at a frequency of di 7 Hz
96 – 103	100	Strobe at a frequency of 8 Hz
104 – 111	108	Strobe at a frequency of 9 Hz
112 – 119	116	Strobe at a frequency of 10 Hz
120 – 136	128	Shutter strobe low strobe effect at maximum flash rate in sync with the bass beat
137 – 153	145	Music flash low
154 – 170	162	Open autoshade on the gobo
171 – 187	179	Open autoshade on the colors
188 – 204	196	Open autoshade on the gobo and on the colors
205 – 221	213	Open with slow gobo change
222 – 255		Open

9.0-Dimmer -ch 9-

Controlled by Channel 9 - enables linear control of light output.

Giotto's dimmer is partially mechanical and partially electronic and allows to obtain good linear regulation as well as high operating speed and very low noise.

DMX512 Level range 0-- 255	FUNCTION
0	CLOSED
000-255	LINEAR REGULATION
255	OPEN

10- GOBO ROTATION - CH 10

This channel is used to control the speed or positioning of the rotary gobos. Rotation can be in either direction at a speed which can be regulated from a minimum of 1.5rpm to a maximum of 40rpm, whereas a gobo's position can be set in a range of 360°.

The exclusive gobo rotation system ensures absolutely smooth rotation and at the same time protects the entire system from the damage caused by dust and humidity on the movement mechanism.

DMX512 Level range 0-- 255	FUNCTION
0 . . 127	POSITIONING 0 – 360°
128 . . 175	ROTATION DOWN MAX ROTATION DOWN MIN
176 – 202	STOPPED
203 . . 255	ROTATION UP MIN ROTTION UP MAX

11-PRISMS - CH 11

This channel is used to select the fixture's two rotary prisms. The prisms multiply projected images by 4 or 9, obtaining eye-catching graphic/decorative effects.

The prisms cannot be superimposed, so must be selected singly.

Lastly, the prism system is completely independent from the gobo system, enabling them to be combined, leaving light designers wide creative freedom.

DMX512 Level range 0-- 255	FUNCTION
0 – 84	NO PRISM INSERTED
85 – 170	4 - FACED PRISM
171 – 255	9 - FACED PRISM

12-PRISM ROTATION -CH 12-

This channel is used to control the speed of the fixture's two rotary prisms.

DMX512 Level range 0-- 255	FUNCTION
0 . . 111	ROTATION DOWN MAX ROTATION DOWN MIN
112 – 143	STOPPED
144 . . 255	ROTATION UP MIN ROTATION UP MAX

13-ELECTRONIC FOCUS -CH 13-

This channel gives smooth precise focus control, obtaining clear projections at any distance or suggestive out-of-focus effects.

DMX 512 <i>level Range 0-255</i>	FUNCTION
000 - 255	Linear Regulation

14-ADDITIONAL LENSES -CH 14-

By means of this channel it's possible to choose projection angle from those available (see table). It's thus possible to obtain wide-angle projections at a short distance or long-throw projections.

DMX VALUE	CENTRAL VALUE	FUNCTION
0 – 42	21	9,6 Degree lens
43 – 85	64	No lens
86 – 128	107	14,5 Degree lens
129 – 171	150	17,7 Degree lens
172 – 214	193	Multi-focal
215 – 255	235	Frost

15-COLOR FILTERS -CH 15-

By means of this channel it's possible to select the two-tone dichroic filters and the color conversion filters (D46CTO and D46 $\frac{1}{2}$ CTO). It's possible to superimpose these filters with the 24 possible colors available, thus obtaining two-tone projections in various shades.

DMX VALUE	CENTRAL VALUE	FUNCTION
0 – 36	18	White
37 – 73	55	Yellow/Cyan dichroic filter
74 – 110	92	Green/Red dichroic filter
111 – 147	129	White/Yellow dichroic filter
148 – 184	166	White/Cyan dichroic filter
185 – 221	203	D46 CTO TC3256 conversion filter
222 – 255	238	D46 $\frac{1}{2}$ CTO TC32LT conversion filter

16 -FROST -CH 16-

Adjustable from channel 16, the linear regulation of the frost concurs.

DMX 512 <i>level Range 0-255</i>	FUNCTION
0	NO Frost inserted
000 - 255	Linear Regulation
255	Frost inserted

17-MSPEED -CH 17-

Mspeed controls PAN and TILT and is intended as the time required to complete a movement from one position to another. This means that fixtures with the same Mspeed value will reach their destination at exactly the same moment. It's therefore possible to set movement times for each fixture which are independent from the times sent by the lighting console.

DMX values between 000-003 allow the lighting console to control the movement, whereas from DMX value 004 it's possible to allocate the movements a movement time.

To determine Mspeed time, refer to the conversion table.

DMX VALUE	FUNCTION
0 – 3	Controller cross fade
4	Slowest
.	.
255	Fastest

18-REMOTE LAMP IGNITION AND RESET- Ch 18 -

The lamp can be switched on (and off) can be controlled via DMX by means of a lighting console. In fact, after the Giotto has been powered up, the lamp will remain off until the "lamp ignition" command is sent.

This function has no effect if it's not enabled by means of the fixture's built-in microcomputer. In this case, the lamp will ignite automatically without waiting to receive the command from the lighting console.

In the event of the lamp being switched off accidentally, it's advisable to wait at least 5 minutes before sending the ignition command. Nevertheless, if the command is sent earlier, Giotto Spot carry out lamp ignition, automatically carrying out restrike attempts at regular intervals of 3 minutes.

Lastly, Giotto Spot 1200 has another function which automatically reduces the power of the lamp by 50% every time the shutter or dimmer are closed. This function ensures considerable improvement in fixture cooling and increases lamp life. The lamp obviously immediately returns to full power as soon as the shutter or dimmer is opened again.

Should any problems arise, a reset command can be sent to the fixture so that all the motors return to the starting position before beginning to carry out the commands received from the lighting console.

DMX512 Level range 0-- 255	FUNCTION	
0 – 60	Off	LAMP
61 – 129	Hysteresis	
130 – 179	On	
180 – 239	Hysteresis	RESET
240 – 255	Reset	

CONVERSION TABLE

DMX VALUE	MSPEED SEC.	DMX VALUE	MSPEED SEC.	DMX VALUE	MSPEED SEC.	DMX VALUE	MSPEED SEC.	DMX VALUE	MSPEEDS SEC.	DMX VALUE
1	0,2	46	176	91	116	136	64	181	25	219
2	0,2	47	175	92	115	137	63	182	24	220
3	0,2	48	173	93	114	138	62	183	23	221
4	243	49	172	94	112	139	61	184	23	222
5	241	50	171	95	111	140	60	185	22	223
6	240	51	169	96	110	141	59	186	22	224
7	238	52	168	97	109	142	58	187	21	225
8	236	53	166	98	108	143	57	188	20	226
9	234	54	165	99	106	144	56	189	20	227
10	233	55	164	100	105	145	55	190	19	228
11	231	56	162	101	104	146	54	191	19	229
12	229	57	161	102	103	147	53	192	18	230
13	227	58	159	103	101	148	52	193	17	231
14	226	59	158	104	100	149	51	194	17	232
15	224	60	157	105	99	150	50	195	16	233
16	222	61	155	106	98	151	49	196	16	234
17	221	62	154	107	97	152	48	197	15	235
18	219	63	153	108	95	153	47	198	15	236
19	217	64	151	109	94	154	46	199	14	237
20	216	65	150	110	93	155	45	200	14	238
21	214	66	149	111	92	156	45	201	13	239
22	213	67	147	112	91	157	44	202	13	240
23	211	68	146	113	90	158	43	203	12	241
24	209	69	145	114	88	159	42	204	12	242
25	208	70	143	115	87	160	41	205	12	243
26	206	71	142	116	86	161	40	206	11	244
27	205	72	141	117	85	162	39	207	11	245
28	203	73	139	118	84	163	38	208	10	246
29	202	74	138	119	83	164	38	209	10	247
30	200	75	137	120	82	165	37	210	10	248
31	199	76	135	121	80	166	36	211	9	249
32	197	77	134	122	79	167	35	212	9	250
33	195	78	133	123	78	168	34	213	9	251
34	194	79	131	124	77	169	34	214	8	252
35	192	80	130	125	76	170	33	215	8	253
36	191	81	129	126	75	171	32	216	8	254
37	189	82	128	127	74	172	31	217	7	255
38	188	83	126	128	73	173	30	218	7	
39	187	84	125	129	72	174	30			
40	185	85	124	130	70	175	29			
41	184	86	122	131	69	176	28			
42	182	87	121	132	68	177	28			
43	181	88	120	133	67	178	27			
44	179	89	119	134	66	179	26			
45	178	90	117	135	65	180	25			

M 001235



SGM Elettronica srl
Via Pio La Torre, 1 • 61010 Tavullia (PS), Italy
Tel. +39 0721 476477 • Fax +39 0721 476170
e-mail: info@sgm.it • <http://www.sgm.it>