

IDEA BEAM 300

MOVING HEADS

- GB
- I
- D
- F
- E
- P



Vi ringraziamo per aver acquistato un prodotto SGM.

Per ottenere i migliori risultati dal suo utilizzo, vi preghiamo di leggere attentamente questo manuale di istruzioni. Al suo interno troverete le informazioni tecniche e le specifiche d'uso del prodotto. Nelle pagine in appendice troverete inoltre schemi e diagrammi destinati all'assistenza tecnica.

Nell'ottica di qualità SGM, è possibile che l'Azienda apporti migliorie ai suoi prodotti, per cui consigliamo di allegare il manuale al prodotto stesso e di trascrivere il numero di serie nell'ultima pagina della copertina: utilizzando il presente manuale con un apparecchio fabbricato prima o dopo la sua stampa, potrebbero esserci discrepanze fra l'apparecchio e quanto riportato nel manuale stesso.

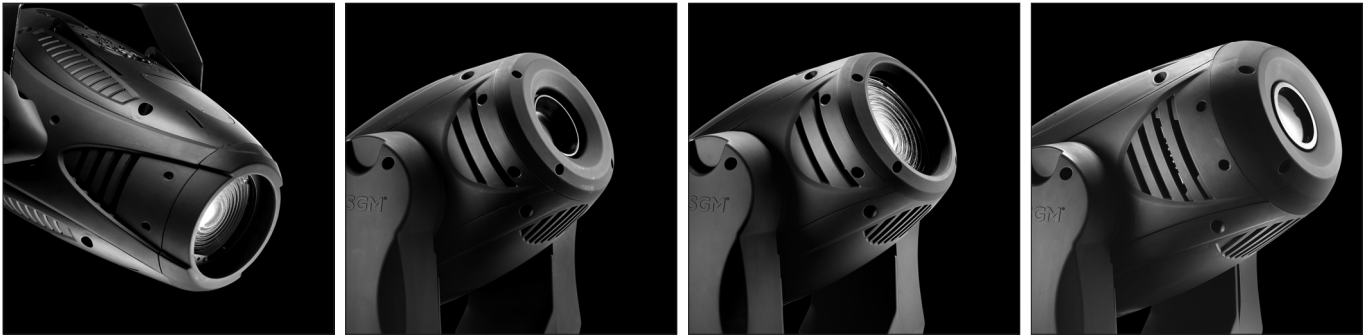

Thank you for buying an SGM product.

To obtain the best results, please carefully read this instruction manual in which you will find technical information and specifications for use of the product, as well as diagrams for technical service in the appendix.

In light of SGM quality, the company may make improvements to its products. Therefore, we recommend that the manual be attached to the product and the serial number copied onto the back cover: using this manual with equipment manufactured before or after its printing, might show discrepancies between the equipment and the information listed in the manual.

Wir danken Ihnen für den Kauf eines Produkts von SGM.

Zur Erzielung der besten Resultate bei der Benutzung bitten wir Sie, die vorliegende Bedienungsanleitung aufmerksam zu lesen. Darin finden Sie die technischen Informationen sowie die Anweisungen für die Benutzung des Produkts. Im Anhang befinden sich außerdem die Schaltpläne und Diagramme für den Kundendienst.

SGM behält sich das Recht vor, Verbesserungen an den Produkten vorzunehmen und deshalb empfehlen wir, die Bedienungsanleitung dem Produkt stets beizulegen und die Seriennummer auf der letzten Seite des Umschlags einzutragen. Bei der Verwendung dieses Handbuches mit einem Gerät, das vor oder nach der Drucklegung produziert wurde, können sich Abweichungen zwischen Gerät und dem Inhalt des Handbuches ergeben.

Nous vous remercions d'avoir acheté un produit SGM.

Pour optimiser son utilisation, nous vous prions de bien vouloir lire attentivement cette notice où vous trouverez les informations techniques et les caractéristiques d'utilisation du produit. En outre, vous trouverez également, dans les pages en appendice, les schémas et les diagrammes concernant l'assistance technique.

Le concept de qualité SGM, lui permet d'améliorer continuellement ses produits et c'est pourquoi nous vous conseillons de joindre la notice au produit et d'inscrire le numéro de série sur la page de couverture. En effet, si on l'utilise avec un appareil fabriqué avant ou après son impression, il peut y avoir des différences entre l'appareil et ce qui figure dans la notice.

Les estamos sumamente agradecidos por haber elegido un producto SGM.

Para obtener los mejores resultados, les rogamos leer detenidamente el presente manual de instrucciones. El mismo contiene las informaciones técnicas y las indicaciones de uso del producto. Las páginas anexas contienen además los esquemas y diagramas necesarios para la asistencia técnica.

Para mantener la calidad SGM, es posible que la Empresa aporte mejoras sus productos, por ello les aconsejamos conservar el manual junto con el aparato correspondiente y escribir su número de serie en la última página del manual; si en cambio se utiliza el presente manual con un aparato frabricado antes o después de su impresión, es probable que existan discrepancias entre el aparato y las indicaciones del mismo.



Table of Contents:

INTRODUCTION: 2
 Features: 2
 OVERVIEW 3
 SAFETY INSTRUCTIONS 4
 GENERAL GUIDELINES..... 5
 INSTALLATION INSTRUCTIONS 5
 Installing or replacing the lamp 5
 Mounting the device..... 7
 Installation method via clamp..... 8
 DMX-512 control connection..... 8
 Control Board..... 1 1
 FUNCTION MODE 1 3
 DMX address setting 1 3
 Slave setting 1 3
 Auto Program..... 1 3
 Music control..... 1 3
 INFORMATION 1 3
 Time information 1 3
 Temp. Info. 1 4
 Software version 1 4
 LAMP CONTROL..... 1 4
 PERSONALITY 1 5
 RESET-FUNCTIONS 1 6
 EFFECT ADJUST 1 6
 USERS MODE SET 1 6
 EDIT PROGRAM..... 1 6
 INSTRUCTIONS ON USE..... 1 9
 ERROR MESSAGE 2 3
 CLEANING AND MAINTENANCE 2 3
 TECHNICAL SPECIFICATIONS 2 4

KEEP THIS MANUAL FOR FUTURE NEEDS

Thank you for your patronage. We are confident that our excellent products and service can satisfy you. For your own safety, please read this user manual carefully before installing the device.

CAUTION !

Keep this device away from rain and moisture!



Unplug mains lead before opening the housing

In order to install , operate, and maintain the lighting safety and correctly. We suggest that the installation and operation should be done by the verified technician and follow the instruction strictly.

INTRODUCTION:

Thank you for having chosen this professional moving head. You will see you have acquired a powerful and versatile device.

Unpack the device. Inside the box you should find: the fixture device, an XLR connection cable, two omega clamps and a safety rope and this manual. Please check carefully that there is no damage caused by transportation. Should there be any, consult your dealer and don't install this device.

Features:

- Lamp: Philips MSR GOLD 300 FASTFIT
- 3 Control channel modes: 16/18/26 channels
- Pan/tilt movement:
 - 8 bit and 16 bit resolution
 - For smooth and precise resolution
 - Pan: 540°/630° optional, Tilt: 246°movement
 - High speed of pan/tilt movement, speed of pan/tilt movement is adjustable
 - Scan position memory, auto reposition after unexpected movement
- CMY color mixture to get indefinite color effects
- 30 CMY and color wheel MACROS and Random CMY
- Motorized color wheel with 8 dichroic filters and open, rainbow-effect with adjustable speed in both directions
- One gobo rotation wheel with 6 rotating gobos plus open each, with different speed of gobo shaking and rainbow effect, and gobo indexing
- Linear dimmer in precise speed from 0~100%
- Stepless frost, 0%~100% linear change frost
- Strobe effect with 13 flashes per second or random strobe via shutter
- Friendly blue LCD display
- Local and remote lamp on/off

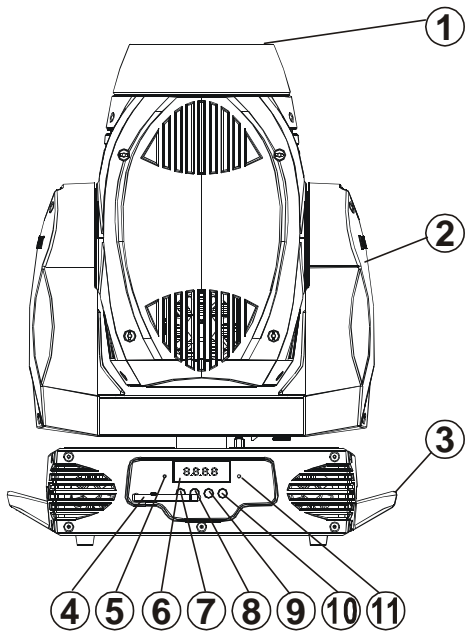

1. Lens
2. Yoke
3. Carrying handle
4. Antenna – Wireless DMX
5. Wireless indicator
6. LCD-Display
7. Mode/esc-button
8. Up-button
9. Down-button
10. Enter-button
11. Microphone

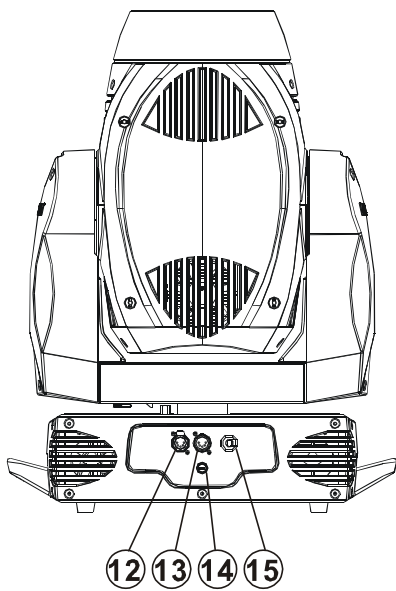

12. 5-PIN DMX output socket
13. 5-PIN DMX input socket
14. Fuse
15. Power supply

SAFETY INSTRUCTIONS

CAUTION



Be careful with your operations. With a dangerous voltage you can suffer a dangerous electric shock when touching wires!

This device has left the factory in perfect condition. In order to maintain this condition and to ensure a safe operation, it is absolutely necessary for the user to follow the safety instructions and warning notes written in this user manual.

IMPORTANT

Damages caused by the disregard of this user manual are not subject to warranty. The dealer will not accept liability for any resulting defects or problems.

If the device has been exposed to temperature changes due to environmental changes, do not switch it on immediately. The arising condensation could damage the device. Leave the device switched off until it has reached room temperature.

This device falls under protection-class I. Therefore it is essential that the device be earthed. The electric connection must be carried out by a qualified person.

The device shall only be used with rated voltage and frequency. Make sure that the available voltage is not higher than stated at the end of this manual.

Make sure the power cord is never crimped or damaged by sharp edges. If this would be the case, replacement of the cable must be done by an authorized dealer.

Always disconnect from the mains, when the device is not in use or before cleaning it. Only handle the power cord by the plug. Never pull out the plug by tugging the power cord.

During initial start-up some smoke or smell may arise. This is a normal process and does not necessarily mean that the device is defective, it should decrease gradually.

Please don't project the beam onto combustible substances.

Fixtures cannot be installed on combustible substances, keep more than 50cm distance with wall for smooth air flow, so there should be no shelter for fans and ventilation for heat radiation.

CAUTION



Never touch device during operation!
The housing may heat up.



Never look directly into the light source,
as sensitive persons may suffer an epileptic shock.

Please be aware that damages caused by manual modifications to the device are not subject to warranty. Keep away from children and non-professionals.

GENERAL GUIDELINES

This device is a lighting effect for professional use on stages, in discotheques, theatres, etc. This fixture is only allowed to be operated with the max alternating current which stated in the technical specifications in the last page of this manual, the device was designed for indoor use only. Lighting effects are not designed for permanent operation. Consistent operational breaks may ensure that the device will function properly for a long time. Do not shake the device. Avoid brute force when installing or operating the device. The device shall only be used complete with its protective shield.

While choosing the installation-spot, please make sure that the device is not exposed to extreme heat, moisture or dust. The minimum distance between light-output from the projector and the illuminated surface must be more than 0.5 meter.

Always fix the fixture with an appropriate safety cable if you use the quick lock cam in hanging up the fixture, please make sure the 4 quick lock fasteners turned in the quick lock holes correctly.

If you use the quick lock cam in hanging up the fixture, please make sure the 4 quick lock fasteners turned in the quick lock holes correctly.

Lighting can not be installed where there is combustible. Keeping 50cm or above away from the wall. Ensure a good ventilation. No barrier in the radiator fan and vent.

Operate the device only after having familiarized with its functions. Do not permit operation by persons not qualified for operating the device. Most damages are the result of unprofessional operation.



Please use the original packaging if the device is to be transported. For safety reasons, please be aware that all modifications on the device are forbidden.

If the external flexible cable or cord of this luminaire is damaged, it shall be exclusively replaced by the manufacturer or his service agent or a similar qualified person in order to avoid a hazard.

If this device will be operated in any way different to the one described in this manual, the product may suffer damages and the guarantee becomes void. Furthermore, any other operation may lead to short-circuit, burns, electric shock, lamp explosion, crash, etc.

INSTALLATION INSTRUCTIONS

Installing or replacing the lamp

| CAUTION | |
|---|---|
|  | Only install the lamp with the device unplugged from the mains. |
|  | The lamp has to be replaced when it is damaged or deformed. |

Before replacing the lamp let the lamp cool down, because during operation, the lamp can reach very high temperature.

During the installation of halogen lamps do not touch the glass bulbs bare handed. Always use a cloth to handle the lamps during insertion and removal. Do not install lamps with a higher wattage. They generate higher temperatures than which the device was designed for.

For the installation, you need one Philips MSR GOLD 300 FASTFIT

Procedure:

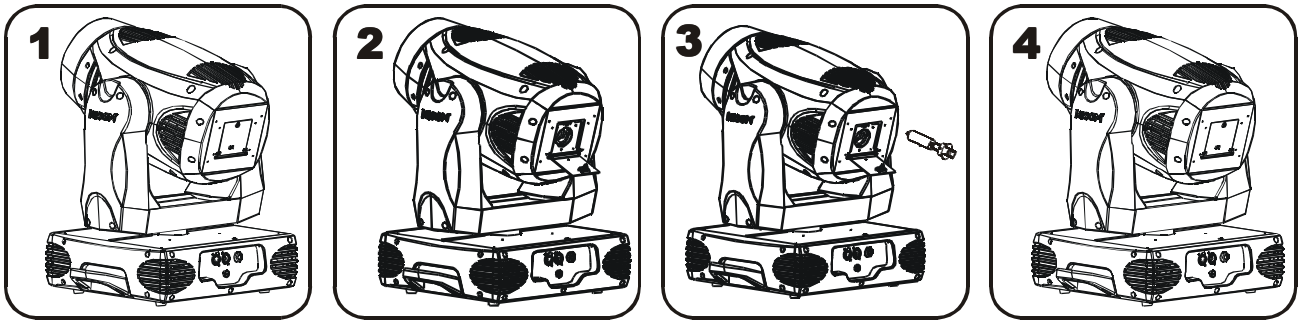

1. Center the hot-spot (the brightest part of the beam) using the 3 adjustment screws located under the lamp cover labeled A, B, and C as illustrated on the next page. Turn one screw at a time to drag the hot-spot diagonally across the projected image. If you cannot detect a hot-spot, adjust the lamp until the light is even.
2. To reduce a hot-spot, pull the lamp in by turning all three screws clockwise a 1/4-turn at a time until the light is evenly distributed.

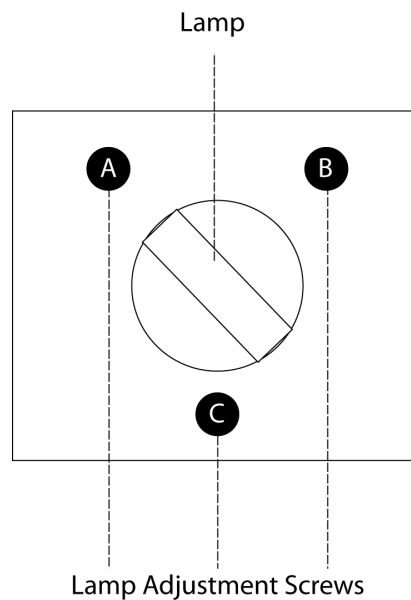

Please remember the lamp is not a hot-restrike type, you must wait for approximately 15 minutes after having turned off the lamp before you can turn it back on again.

CAUTION



Do not operate this device with open cover.

Mounting the device



CAUTION

Please consider the EN 60598-2-17 and the other respective national norms during the installation. The installation must only be carried out by a qualified person.

The applicable temperature for the lighting is between -25°C ~ 45°C . Do not use the lighting under or above the temperature.

The installation of the effect has to be built and constructed in a way that it can hold 10 times the weight for 1 hour without any harming deformation.

The installation must always be secured with a secondary safety attachment, e.g. an appropriate safety cable.

Never stand directly below the device when mounting, removing or servicing the fixture.

The operator has to make sure the safety relating and machine technical installations are approved by an expert before taking the device into operation for the first time.

These installations have to be approved by a skilled person once a year.



CAUTION

Before taking into operation for the first time, the installation has to be approved by an expert.

Cautions:

The effect should be installed outside areas where persons may reach it, walk by or be seated.



CAUTION

When installing the device, make sure there is no highly inflammable material within a distance of min. 0,5m

Overhead mounting requires extensive experience, including amongst others calculating working load limits, installation material being used, and periodic safety inspection of all installation material and the device. If you lack these qualifications, do not attempt the installation yourself. Improper installation can result in bodily injury.



CAUTION

The electric connection must only be carried out by a qualified electrician.

Before mounting make sure that the installation area can hold a minimum point load of 10 times the device's weight.

Connect the fixture to the mains with the power plug.

Installation method via clamp

Please refer to the picture below:

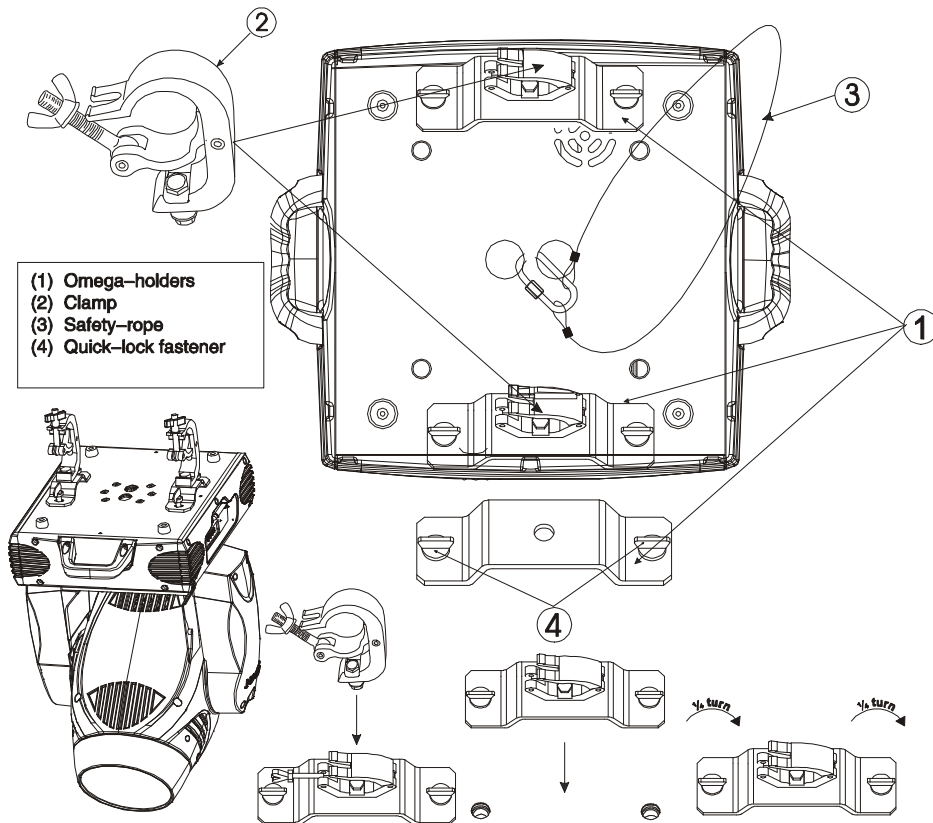

Screw one clamp each via a M12 screw and nut onto the Omega holders.
 Insert the quick-lock fasteners of the first Omega holder into the respective holes on the bottom of the device. Tighten the quick-lock fasteners fully clockwise. Install the second Omega holder.
Pull the safety-rope through the holes on the bottom of the base and over the trussing system or a safe fixation spot. Insert the end in the carabine and tighten the safety screw.

DMX-512 control connection

Connect the provided XLR cable to the female 3-pin XLR output of your controller and the other side to the male 3-pin XLR input of the moving head. You can chain multiple Moving head together through serial linking. The cable needed should be two core, screened cable with XLR input and output connectors. Please refer to the diagram below.

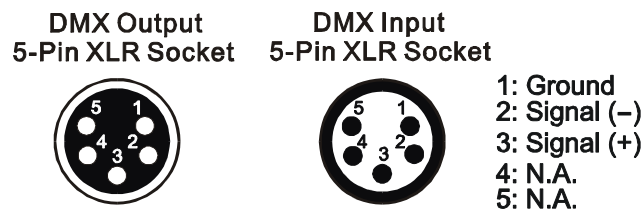

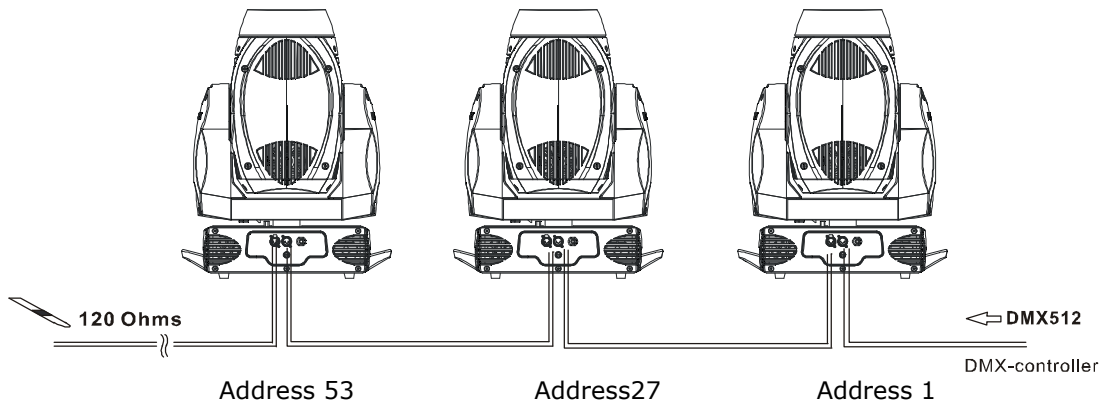

DMX-512 connection with DMX terminator

For installations where the DMX cable has to run a long distance or is in an electrically noisy environment, such as in a discotheque, it is recommended to use a DMX terminator. This helps in preventing corruption of the digital control signal by electrical noise. The DMX terminator is simply an XLR plug with a 120 Ω resistor connected between pins 2 and 3, which is then plugged into the output XLR socket of the last fixture in the chain. Please see illustrations below.

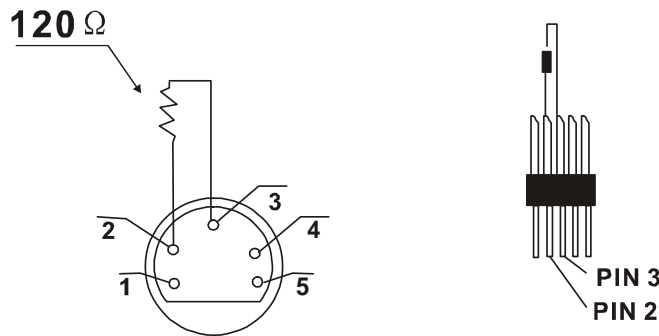

Projector DMX starting address selection

All fixtures should be given a DMX starting address when using a DMX signal, so that the correct fixture responds to the correct control signals. This digital starting address is the channel number from which the fixture starts to “listen” to the digital control information sent out from the DMX controller. The allocation of this starting address is achieved by setting the correct number on the display located on the base of the device.

You can set the same starting address for all fixtures or a group of fixtures, or make different address for each fixture individually.

If you set the same address, all the units will start to “listen” to the same control signal from the same channel number. In other words, changing the settings of one channel will affect all the fixtures simultaneously.

If you set a different address, each unit will start to “listen” to the channel number you have set, based on the quantity of control channels of the unit. That means changing the settings of one channel will affect only the selected fixture.

In the case of the moving head, which is 26 channels fixture when you select the standard channel mode, you should set the starting address of the first unit to 1, the second unit to 27(26 + 1), the third unit to 53 (27+ 26), and so on.

Operating instructions of the internal DMX wireless system

1. Equipments:
DMX 512 controller, wireless transmitter, and the fixtures with wireless receiver.
 2. Message from the LED indicator:
 1. Rapid flashing red/Green: logging in to a transmitter
 2. Slow flashing Red/Green: Logged on a transmitter and the DMX line is idle (No DMX is connected to transmitter).
 3. Solid Green: Logged on to a transmitter and receiving DMX data.
 4. Solid Red: Not logged on to a transmitter (free)
 3. WDMX in the menu of the fixture:
On a fixture installed with wireless system, in order to switch between wireless control system and traditional DMX control (with cable), a new menu WDMX is added to the display board.
ON: (Activate WDMX)
 1. When the fixture is on power, and the WDMX is activated to ON status, but did not connect to the controller and did not log in to the transmitter, the fixture will search for the DMX signal source. If the fixture is connected to the DMX controller it can be controlled by DMX controller; if it is log in to the wireless transmitter, it can be controlled by the Transmitter
 2. When the fixture is power off, and the WDMX is in ON status, if the fixture is connected to DMX controller. After the fixture is power on, it can be controlled only by the DMX controller which connected. The fixture can log in the wireless transmitter, and receive only radio signal from transmitter, but not DMX from the transmitter.
OFF: (De-activate WDMX)
In this status, wireless system is not activated, so the fixture can not log in the transmitter.
REST: (reset WDMX memory);
Can remove the fixture from the connection with the transmitter, the fixture become free and ready to log in any transmitter.
 4. Setup the wireless system:
 1. Connect the transmitter with the DMX controller
 2. To make the fixture installed with wireless receiver log in to the transmitter
 - a) Initially, the indicator on the receiver fixture should be in Solid red
 - b) Press and hold the configuration button on transmitter for less than 3 seconds the red/green LEDs on the transmitter and the receiver fixture will flash rapidly for about 5~ 10 seconds while the system goes through its setup procedure.
 - c) Once the receiver fixture is logged in to the transmitter (T1), the fixture with wireless receiver will keep the memory, even if restart the power, this unit will log in the transmitter (T1) automatically.
 3. Use the DMX 512 to control the fixture
 5. Remove the receivers from transmitter (T1) and to log in to another transmitter (T2)

Case 1: Remove a receiver:

 - a) On the control board of the fixture, enter menu to activated the function of REST;
 - b) The LED for wireless on the fixture should turn to Solid red; the receiver can log out from the transmitter (T1);
 - c) press the configuration button on transmitter(T2) for less than 3 second, then the fixture will start to connect with the transmitter(T2)

Case 2: Remove all receivers from a transmitter (T1) to log in to T2;

 - a) Press and hold the configuration button on the T1 as least 5 seconds, can clear the connection with all the fixtures.
 - b) All the red/green LEDs on the receiver fixtures will turn to Solid red to indicate that the receivers are unassigned and removed from the transmitter (T1);
 - c) Press and hold the configuration button on the T2 less then less than 3 second , the fixtures will connect with the T2
- PS:
1. Please log the receivers out from the transmitter after every job, so that the receivers are in free un assigned state and ready to be assigned to a transmitter.
 2. Do not connect the fixture which is under the communication of wireless system to the DMX controller, otherwise it will cause interference from the DMX controller.

Control Board

The Control Board offers several features: you can simply set the starting address, switch on and off the lamp, run the pre-programmed program or make a reset.

The main menu is accessed by pressing the **Mode/esc**-button until the display starts flashing. Browse through the menu by pressing the **Up**-button or **Down**-button. Press the **Enter**-button in order to select the desired menu. You can change the selection by pressing the **Up**-button or **Down**-button. Confirm every selection by pressing the **Enter**-button. You can leave every mode by pressing the **Mode/esc**-button. The functions provided are described in the following sections.

To access display Menu via the internal battery, press the UP & DOWN buttons simultaneously. Display will automatically switch off after about 10 seconds from last button press.

Default settings shaded

| | | | | |
|------------------|-------------------|-------------------------------|-------------------------------|--------------------------|
| Function Mode | Set Dmx Address | A001~AXXX | DMX address setting | |
| | Value Display | PAN..... | DMX value display | |
| | Set To Slave | Slave1,Slave2,Slave3 | Slave setting | |
| | Auto Program | Master / Alone | Auto program | |
| | Music Control | Master / Alone | Music control | |
| Information | Time Information | Current Time | XXXX(Hours) | Power on running time |
| | | Total Life Hours | XXXX(Hours) | Fixture running time |
| | | Last Run Hours | XXXX(Hours) | Fixture Last times clear |
| Lamp Hours | | XXXX(Hours) | Lamp running time | |
| Lamp Off Time | | XXXX(Minute) | Lamp off time | |
| Timer Password | | Password=XXX | Timer Password 038 | |
| Clear Last Run | | ON/OFF | Clear Fixture Last time | |
| L-Timer Password | | Password=XXX | Lamp Password | |
| Clear Lamp Time | | ON/OFF | Code="038" Clear lamp time | |
| Temperature Info | Head Temperature | XXX□/□ | Temperature in the head | |
| Software Version | Ver1.0..... | | Software version of each IC | |
| Lamp Control | Lamp On or Off | ON/OFF | Lamp on/off | |
| | Automatic La-On | ON/OFF | Lamp on/off when Power on | |
| | Lamp On Via DMX | ON/OFF | Lamp on via DMX | |
| | Lamp Off Via DMX | ON/OFF | Lamp off via DMX | |
| | Lamp Off No DMX | OFF, OFF~19M | Lamp off if no DMX | |
| | Lamp On at Temp. | 20~79□, 45□ /68~174□ 113□ | Lamp restart at temp. | |
| | Lamp Off at Temp. | 80~139□, 130□ /176~282□, 266□ | Lamp off at temp. | |
| Personality | Status Settings | Address via DMX | ON/OFF | Add. via DMX |
| | | No DMX Status | Close/Hold/Auto/Music | Auto run if no DMX |
| | | Pan Reverse | ON/OFF | Pan Reverse movement |
| | | Tilt Reverse | ON/OFF | Tilt Reverse movement |
| | | Pan Degree | 630/540 | Pan Degree Select |
| | | Feedback | ON/OFF | Movement Feedback switch |
| | | Movement Speed | Speed 1~ 4 | Movement Mode Select |
| | Mic Sensitivity | 0~99% | Sensitivity of Mic. | |
| | Service Setting | Service Password | Password=XXX | Service Code"=050" |
| Fan Voltage | | High/Low | Fan Voltage Select | |
| Gobo Speed | | Quick/Slow | Gobo Change Speed | |
| Fans Control | Auto Fans Speed | | Fans Speed Mode Select | |
| | High Fans Speed | | | |
| | Low Fans Speed | | | |



| | | | | | |
|----------------|---|---|---|---|---|
| | Display Setting | Shutoff Time | | Display shutoff time | |
| | Temperature C/F | Celsius Fahrenheit | | Temperature switch between □/□ | |
| | Initial Effect | PAN..... | PAN =XXX | Initial effect position | |
| | Wireless DMX | De-Act WDMX Activate WDMX Act & Data Out Rest WDMX Mem | | De-activate WDMX Activate WDMX Act & Data Out Reset Wireless DMX Mem | |
| | Reset Default | ON/OFF | | Restore factory set. | |
| Reset Function | Reset All Reset Pan&Tilt Reset Colors Reset Gobos Reset Shutter Reset Others | | | Reset all motors Reset Pan/Tilt Reset color wheel Reset gobos Reset shutter and/or dimmer Reset other motors | |
| Effect Adjust | Test Channel | PAN | | Test function | |
| | Manual Control | PAN : | PAN =XXX : | Fine adjustment of the lamp | |
| | Calibrate Values | --Password-- Color wheel : | Password=XXX Color wheel=XXX : | Calbrate and adjust the effects to standard/right position Password "050" | |
| Users Mode Set | User Mode | Standard Mode Basic Mode Extended Mode User Mode A User Mode B User Mode C | | User's mode to change channel numbers | |
| | Edit User Mode | Max Channel PAN : | Max Channel = XX PAN = CH01 : | Preset User modes | |
| Edit Program | Select Programs | Auto Pro Part 1 Auto Pro Part 2 Auto Pro Part 3 | Program 1 ~ 10 Program 1 ~ 10 Program 1 ~ 10 | Program 1 Program 2 Program 3 | Select programs to be run |
| | Edit Program | Program 1 : Program 10 | Program Test Step 01=SCxxx Step 64=SCxxx | ("STEP XX") | Testing program Program in loop Save and exit |
| | Edit Scenes | Edit Scene 001 ~ Edit Scene 250 | Pan,Tilt,..... --Secne Time-- Input By Outside | Pan=xxx..... TIME=xx.xs | Save and automatically return manual scenes edit |
| | Rec. Controller | XX~XX | | | Automat. scenes rec |

FUNCTION MODE

DMX address setting

With this function, you can adjust the desired DMX-address via the Control Board.

- Select **"Set DMX address"** via the encoder.
- Press the encoder, adjust the DMX address by turning the encoder.
- Press the encoder to confirm.
- Press the Mode/Esc-button in order return to the main menu.

Display the DMX 512 value of each channel

With this function you can display the DMX 512 value of each channel. The display automatically shows the channel with a value changing.

Slave setting

With this function, you can define the device as slave.

Auto Program

With this function, you can run the internal program. You can select the desired program under **"Select program"**. You can set the number of steps under **"Edit program"**. You can edit the individual scenes under **"Edit scenes"**. With this function, you can run the individual scenes either automatically, i.e. with the adjusted Step-Time.

Music control

With this function, you can run the internal program sound-controlled.

INFORMATION

Time information

Current Time

With this function, you can display the temporary running time of the device from the last power on. The display shows "XXXX", "XXXX" stands for the number of hours. The counter is resetted after turning the device off.

Total life Hours

With this function, you can display the running time of the device. The display shows "XXXX", "XXXX" stands for the number of hours.

Last Run Hours

With this function, you can display last the running time of the lamp. The display shows "XXXX", "XXXX" stands for the number of hours.

Lamp Hours

With this function, you can display the running time of the lamp. The display shows "XXXX", "XXXX" stands for the number of hours.

Lamp off time

With this function, you can display the temporary running time of the lamp from the last lamp on. The display

Shows "XXXX", "XXXX" stands for the number of hours. The counter is resetted after turning the lamp off.

Time Password

With this function, you can display the timer password. The time password is 038.

Clear Last Run

With this function, you can clear last run time of the fixture. The display shows "ON" or "OFF", Press "Enter" to confirm.

L-Time Password

With this function, you can display the timer password. The time password is 038.

Clear lamp time

With this function you can clear the running time of the lamp. Please clear the lamp time every time you replace the lamp.

- Select "**Clear lamp time**" by turning the encoder.
- Press the encoder, the display shows "ON" or "OFF".
- Press the encoder to confirm.
- Press the Mode/Esc-button in order to return to the main menu.

Temp. Info.**Head Temp**

With this function you can display the temperature on the display board of the base (near CMY-filter) in Celsius.

Software version

With this function, you can display the software version of the device.

- Select "**Software version**" by turning the encoder.
- Press the encoder, the display shows "**V-X.X**", "X.X" stands for the version number, e.g. "V-1.0", "V-2.6".
- Turn the encoder in order to read the version of every individual IC.
- Press the Mode/Esc-button in order to return to the main menu.

LAMP CONTROL

When the real temperature around the lamp is higher than the preset value, the lamp will be shut down in 5 minutes automatically.

When the LCD display shows "Off", it means the lamp must be turned on again manually;

When the LCD display shows "Hot", it means the actual temperature around the lamp is still higher than the preset value, so even the lamp can not be striked even the menu Lamp is turned to ON, as the lamp switch is compelled to turned off.

When the temperature unit after the temperature value come to lowercase letter "c" or "f", it means menu Lamp is turned to ON, but the lamp is not full dimming up.

When the temperature unit after the temperature value come to capital letter "C" or "F", it menu Lamp is turned to ON, and the lamp is full intensity.

Lamp on/off

With this function you can switch the lamp on or off via the Control Board.

- Select "**Lamp on/off**" by turning the encoder.
- Press the encoder, the display shows "**ON**" or "**OFF**".
- Turn the encoder to select "**ON**" if you wish to strike the lamp or "**OFF**" in order to switch it off.
- Press the encoder to confirm.
- Press the Mode/Esc-button in order to return to the main menu.

Remark: The menu Lamp On/Off is the software command only, the lamp can be striked successfully only when the menu Lamp is set to ON and the actual temperature is lower than the limited value.

Lamp on/off when power on

With this function you can select if the lamp will be switched on when switching the power on. Select "**ON**" by turning the encoder if you wish to enable this function or "**OFF**" if you don't.

Lamp on via external controller

With this function you can select if you can switch the lamp on via an external controller (DMX-channel of internal programs, value 64-79). Select "**ON**" by turning the encoder if you wish to enable this function or "**OFF**" if you don't.

Lamp off via external controller

With this function you can select if you can switch the lamp off via an external controller (DMX-channel of internal programs, value 224-239). Select "**ON**" by turning the encoder if you wish to enable this function or "**OFF**" if you don't.

Lamp Off if no DMX

With this function you can select to switch off the lamp off automatically if there is no DMX signal). Select "**OFF**" by turning the encoder if you wish to switch off the lamp automatically at once, Select "**19M**" by turning the encoder if you wish to postpone to 19 minutes switch off the lamp automatically.

Lamp on at temp.

With this function you can set the inside temperature from which the projector will restrike the lamp after automatic lamp shut off.

Lamp off at temp.

With this function you can set the inside temperature at which the projector will automatically switch the lamp off. Turn the encoder to select the maximum inside temperature between 60° C and 159° C. Inside temperatures below 90° C are not critical. 90° C and more should lead to the lamp being switched off. Please note that the outside temperature should not exceed 45° C.

When the temperature around the lamp is higher than the preset value continuously up to 5 minutes, the lamp will be shut off automatically.

If the lamp be shut off automatically due to over heat, it can not be striked again automatically, it must be turned on again by manually.

PERSONALITY

Status Settings

Address via DMX

With this function, you can adjust the desired DMX-address via an external controller.

- Select "**Address via DMX**" by turning the encoder.
- Press the encoder, the display shows "ON" or "OFF".
- Turn the encoder to select "ON" if you wish to enable this function or "OFF" if you don't.
- Press the encoder to confirm.
- Press the Mode/Esc-button in order to return to the main menu.
- On the controller, set the DMX-value of channel 1 to "7".
- Set the DMX-value of channel 2 to "7" or "8". When set to "7" you can adjust the starting address between 1 and 255. When set to "8" you can adjust the starting address between 256 and 511.
- Set the DMX-value of channel 3 to the desired starting address. If you want to set the starting address to 57, set channel 1 to "7", channel 2 to "7" and channel 3 to "57". If you want to set the starting address to 420, set channel 1 to "7", channel 2 to "8" and channel 3 to "164" (256+164=420).
- Wait for approx. 20 seconds and the unit will carry out a reset. After that, the new starting address is set.

No DMX Status

With this function, when the drive is not DMX signal, it runs automatism, close, hold and music, the default is hold.

Pan Reverse

With this function you can reverse the Pan-movement.

Tilt Reverse

With this function you can reverse the Tilt-movement.

Pan Degree

With this function, you can select pan degree for 630 or 540.

Feedback

With this function, you can feedback switch of pan movement or tilt movement.

Movement Speed

With this function, you can select scan mode from 1 to 4.

Mic Sensitivity

With this function, the default is 70%, you can select the desired microphone sensitivity from 0 % to 99 %.

Service setting

Service Password

With this function, you can set the service password.

Fan Voltage

With this function, you can select fan voltage for high or low, the default is low

Attention: The model is not recommended when ambient temperature is higher than 15 Celsius degree.

Gobo speed

With this function, you can select GOBO speed for quick or slow, the default is slow.

Fans Control

With this function, you can set the speed of the running fans. The selections have Auto, high and low.

Display Setting**Shut off time**

With this function you can shut off the LCD display after 2 to 59 minutes. Turn the encoder in order to select the desired shut off time.

Temperature C/F

With this function, Display the temperature for Celsius or Fahrenheit.

Initial effect

With this function, Display initial effect position.

Wireless DMX

From factory, this projector is prepared for wireless data transmission (W-DMX). If you wish to de-activate W-DMX control, you can select the function "De-activate WDMX" by turning the encoder. With the function "rest", you can log out the projector from the wireless sender.

Reset Default

With this function, you can select restore factory set for ON or OFF, the default is OFF.

RESET-FUNCTIONS

With this function you can reset the device via the Control Board. You can select the different reset functions by turning the encoder.

EFFECT ADJUST**Test function of each channel**

With this function you can test each channel on its (correct) function.

Lamp adjustment

With this function, you can adjust the lamp more easily. All effects will be canceled, the shutter opens and the dimmer intensity will be set to 100 %. With the individual functions, you can focus the light on a flat surface (wall) and perform the fine lamp adjustment.

Calibrate values

With this function, you can calibrate and adjust the effect wheels to their correct positions. The password of calibrate values is 050.

USERS MODE SET

In this menu, user can select different channels list by different sequence:

For example, after the user enter this manual, if select Auto Program = CH 22, means in this User's mode, the "Dimmer" is in Channel 16.

User mode

With this function, you can create user defined channel orders.

Preset User mode

With this function, you can adjust the rest user defined channel order.

EDIT PROGRAM**Select program**

With this function, you can select the program for the Program Run.

Edit program

With this function, you can edit the internal programs.

Edit scenes

With this function, you can edit the scenes of the internal programs.

Auto scenes rec.

The moving head features an integrated DMX-recorder by which you can transmit the programmed scenes from your DMX-controller to the moving head. Adjust the desired scene numbers via the encoder (from – to). When you call up the scenes at your controller, they will automatically be transmitted to the moving head.

Excursion:

A Master unit can send up to 3 different data groups to the Slave units, i.e. a Master unit can start 3 different Slave units, which run 3 different programs. The Master unit sends the 3 program parts in a continuous loop.

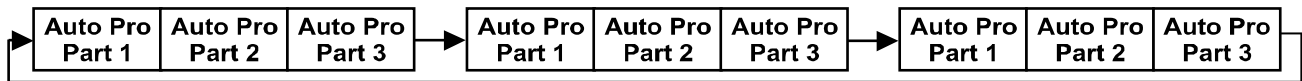

The Slave unit receives data from the Master unit according to the group which the Slave unit was assigned to. If e.g. a Slave unit is set to "Slave 1" in the menu "Set to Slave", the Master unit sends "Auto Program Part 1" to the Slave unit. If set to "Slave 2", the Slave unit receives "Auto Program Part 2".

To start a Auto Program please proceed as follows:

1. Slave-Setting

- Select "Function Mode" by turning the encoder.
- Press the Enter button to confirm.
- Select "Set to slave" by turning the encoder.
- Press the Enter button to confirm.
- Turn the encoder to select "Slave 1", "Slave 2" or "Slave 3".
- Press the Enter button to confirm.
- Press the Mode/Esc button in order to return to the main menu.

2. Automatic Program Run

- Select "Function Mode" by turning the encoder.
- Press the Enter button to confirm.
- Select "Auto Program" by turning the encoder.
- Press the Enter button to confirm.
- Turn the encoder to select "Master" or "Alone". The selection "Alone" means Stand Alone-mode and "Master" that the device is defined as master.
- Press the Enter button to confirm.
- Press the Mode/Esc button in order to return to the main menu.

3. Program selection for Auto Pro Part

- Select "Edit program" by turning the encoder.
- Press the Enter button to confirm.
- Select "Select programs" by turning the encoder.
- Press the Enter button to confirm.
- Turn the encoder to select "Auto Pro Part 1", "Auto Pro Part 2" or "Auto Pro Part 3", and thus select which Slave program is to be sent. Selection "Part 1" means, that the Slave unit runs the same program as the master units.
- Press the Enter button to confirm.
- Press the Mode/Esc button in order to return to the main menu.

4. Program selection for Edit Program

- Select "Edit program" by turning the encoder.
- Press the Enter button to confirm.
- Select "Edit program" by turning the encoder.
- Press the Enter button to confirm.
- Turn the encoder to select the desired program. With this function you can edit specific scenes into a specific program.
- Press the Enter button to confirm.
- Press the Mode/Esc button in order to return to the main menu.

5. Automatic Scene Recording

- Select "Edit program" by turning the encoder.
- Press the Enter button to confirm.
- Select "Edit scenes" by turning the encoder.
- Turn the encoder to select the desired scene numbers. You can program a maximum number of 250 • Turn the encoder to select the desired scene numbers. You can program a maximum number of 250 scenes.
- Press the Enter button to confirm.
- Press the Mode/Esc button in order to return to the main menu.

Example:

Program 2 includes scenes: 10, 11, 12, 13

Program 4 includes scenes: 8, 9, 10

Program 6 includes scenes: 12, 13, 14, 15, 16

Auto Pro Part 1 is Program 2;

Auto Pro Part 2 is Program 3;

Auto Pro Part 3 is Program 6

The 3 Slave groups run the Auto Program in certain time segments, as shown in the following picture:

Part 1:

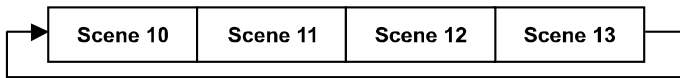

Part 2:

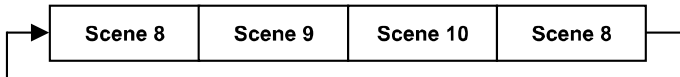

Part 3:

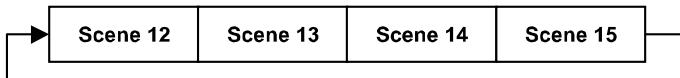

INSTRUCTIONS ON USE



| DMX channel 's functions and their values (26 DMX channels): | | | | |
|--|--|----|---------|--|
| Mode/Channel | | | Value | Function |
| St | Ba | Ex | | |
| 1 | 1 | 1 | | <u>PAN Movement 8bit :</u> |
| | | | 0-255 | Pan Movement |
| 2 | | 2 | | <u>Pan Fine 16bit</u> |
| | | | 0-255 | Fine control of Pan movement |
| 3 | 2 | 3 | | <u>TILT Movement 8bit :</u> |
| | | | 0-255 | Tilt Movement |
| 4 | | 4 | | <u>Tilt Fine 16bit</u> |
| | | | 0-255 | Fine control of Tilt movement |
| 5 | 3 | 5 | | <u>Speed Pan/Tilt movement:</u> |
| | | | 0-225 | max to min speed |
| | | | 226-235 | blackout by movement |
| | | | 236-245 | blackout by all wheel changing |
| | | | 246-255 | no function |
| 6 | 4 | 6 | | <u>Color Wheel:</u> |
| | | | 0-13 | Open / white |
| | | | 14-27 | Color 1 |
| | | | 28-41 | Color 2 |
| | | | 42-55 | Color 3 |
| | | | 56-69 | Color 4 |
| | | | 70-83 | Color 5 |
| | | | 84-97 | Color 6 |
| | | | 98-111 | Color 7 |
| | | | 112-127 | Color 8 |
| | | | 128-189 | Forwards rainbow effect from fast to slow |
| | | | 190-193 | No rotation |
| 194-255 | Backwards rainbow effect from slow to fast | | | |
| | | 7 | | <u>Color Wheel Fine :</u> |
| | | | 0-255 | Color Wheel colour change to any position Fine |
| 7 | 5 | 8 | | <u>Cyan Color :</u> |
| | | | 0-255 | Cyan (0-white, 255-100% Cyan) |
| | | 9 | | <u>Cyan Color Fine :</u> |
| | | | 0-255 | Cyan Fine |
| 8 | 6 | 10 | | <u>Magenta Color :</u> |
| | | | 0-255 | Magenta (0-white, 255-100% magenta) |
| | | 11 | | <u>Magenta Color Fine :</u> |
| | | | 0-255 | Magenta Fine |
| 9 | 7 | 12 | | <u>Yellow Color :</u> |
| | | | 0-255 | Yellow (0-white, 255-100% Yellow) |
| | | 13 | | <u>Yellow Color Fine :</u> |
| | | | 0-255 | Yellow Fine |

| | | | | |
|---------|---|----|---------|--|
| 10 | 8 | 14 | | <u>Rotating gobos, cont. rotation:</u> |
| | | | 0-9 | Open |
| | | | 10-19 | Rot. gobo 1 |
| | | | 20-29 | Rot. gobo 2 |
| | | | 30-39 | Rot. gobo 3 |
| | | | 40-49 | Rot. gobo 4 |
| | | | 50-59 | Rot. gobo 5 |
| | | | 60-69 | Rot. gobo 6 |
| | | | 70-89 | Gobo 1 shake slow to fast |
| | | | 90-109 | Gobo 2 shake slow to fast |
| | | | 110-129 | Gobo 3 shake slow to fast |
| | | | 130-149 | Gobo 4 shake slow to fast |
| | | | 150-169 | Gobo 5 shake slow to fast |
| | | | 170-189 | Gobo 6 shake slow to fast |
| 190-255 | Rot. gobo wheel cont. rotation slow to fast | | | |
| 11 | 9 | 15 | | <u>Rotating gobo index, rotating gobo rotation :</u> |
| | | | 0-127 | Gobo indexing |
| | | | 128-189 | Forwards gobo rotation from fast to slow |
| | | | 190-193 | No rotation |
| | | | 194-255 | Backwards gobo rotation from slow to fast |
| | | 16 | | <u>Rotating gobo indexing Fine</u> |
| | | | 0-255 | Fine indexing |
| 12 | 10 | 17 | | <u>Shutter, strobe:</u> |
| | | | 0-31 | Shutter closed |
| | | | 32-63 | No function (shutter open) |
| | | | 64-95 | Strobe effect slow to fast |
| | | | 96-127 | No function (shutter open) |
| | | | 128-159 | Pulse-effect in sequences |
| | | | 160-191 | No function (shutter open) |
| | | | 192-223 | Random strobe effect slow to fast |
| 224-255 | No function (shutter open) | | | |
| 13 | 11 | 18 | | <u>Dimmer intensity:</u> |
| | | | 0-255 | Intensity 0 to 100% |
| | | 19 | | <u>Fine Dimmer intensity:</u> |
| | | | 0-255 | Dimmer intensity fine |
| 14 | 12 | 20 | | <u>Rotating Effect index, rotating Effect rotation:</u> |
| | | | 0-3 | NO Effect |
| | | | 4-127 | Effect indexing |
| | | | 128-189 | Forwards prism rotation from fast to slow |
| | | | 190-193 | No rotation |
| | | | 194-255 | Backwards prism rotation from slow to fast |
| | | 21 | | <u>Rotating Effect indexing Fine</u> |
| | | | 0-255 | Fine indexing |
| 15 | 13 | 22 | | <u>Frost:</u> |

| | | | | |
|----|----|----|---------|---|
| | | | 0-255 | Frost 0~100% |
| | | 23 | | Frost Fine: |
| | | | 0-255 | Frost Fine |
| 16 | 14 | 24 | | Speed Of CMY & Colour macro Speed: |
| | | | 0-255 | Speed Max →Min |
| | | | | Colour macros - CMY and colour wheel: |
| | | | 0-7 | OFF |
| | | | 8-15 | Macro1 |
| | | | 16-23 | Macro2 |
| | | | 24-31 | Macro3 |
| | | | 32-39 | Macro4 |
| | | | 40-47 | Macro5 |
| | | | 48-55 | Macro6 |
| | | | 56-63 | Macro7 |
| | | | 64-71 | Macro8 |
| | | | 72-79 | Macro9 |
| | | | 80-87 | Macro10 |
| | | | 88-95 | Macro11 |
| | | | 96-103 | Macro12 |
| | | | 104-111 | Macro13 |
| | | | 112-119 | Macro14 |
| 17 | 15 | 25 | 120-127 | Macro15 |
| | | | 128-135 | Macro16 |
| | | | 136-143 | Macro17 |
| | | | 144-151 | Macro18 |
| | | | 152-159 | Macro19 |
| | | | 160-167 | Macro20 |
| | | | 168-175 | Macro21 |
| | | | 176-183 | Macro22 |
| | | | 184-191 | Macro23 |
| | | | 192-199 | Macro24 |
| | | | 200-207 | Macro25 |
| | | | 208-215 | Macro26 |
| | | | 216-223 | Macro27 |
| | | | 224-231 | Macro28 |
| | | | 232-239 | Macro29 |
| | | | 240-247 | Macro30 |
| | | | 248-255 | Random CMY |
| 18 | 16 | 26 | | Lamp on/off, reset, internal programs: |
| | | | 0-19 | colour & gobo change normal |
| | | | 20-29 | colour change to any position |
| | | | 30-39 | colour & gobo change to any position |
| | | | 40-59 | Lamp on |
| | | | 60-79 | Lamp switch off |

| | | |
|--|---------|---|
| | 80-84 | All motor reset |
| | 85-87 | Scan motor reset |
| | 88-90 | Colors motor reset |
| | 91-93 | Gobo motor reset |
| | 94-96 | Shutter & Dimmer motor reset |
| | 97-99 | Other motor reset |
| | 100-119 | Internal program 1 (secne1~8 of EEPROM) |
| | 120-139 | Internal program 2 (secne9~16 of EEPROM) |
| | 140-159 | Internal program 3 (secne17~24 of EEPROM) |
| | 160-179 | Internal program 4 (secne25~32 of EEPROM) |
| | 180-199 | Internal program 5 (secne33~40 of EEPROM) |
| | 200-219 | Internal program 6 (secne41~48 of EEPROM) |
| | 220-239 | Internal program 7 (secne49~56 of EEPROM) |
| | 240-255 | Music Control (secne of Program 1) |

ERROR MESSAGE

When you turn on the fixture, it will make a reset first. The display may show "XXer" while there are problems with one or more channels. "XX" stands for channel 1, 2, 3, etc who has the testing sensor for positioning.

For example, when the display shows "Cyan color Er", it means there is some error in channel 1. If there are some errors on channel 1, channel 2, channel 5 at the same time, you may see the error message "Cyan Color Er", "Cyan Color Fine Er", "PAN Movement 8bit Er" flash repeated for 5 times, and then the fixture will generate a reset signal, all the stepper reset. If the fixture remain error message after performing reset more than 3 times, it will detect whether the fixture has more than 3 errors. If the fixture has more than 3 errors (including 3 errors), all the channels can not work properly; but if the fixture has less than 3 errors, only the channels which have errors can not work properly, others can work as usual.

Color wheel Er

(Color wheel- error) This message will appear after the reset of the fixture if the magnetic-indexing circuit malfunction (sensor failed or magnet missing) or the stepping-motor is defective (or its driving IC on the main PCB). The color wheel is not located in the default position after the reset.

PAN- movement Er

(PAN-yoke movement error) This message will appear after the reset of the fixture if the yoke's magnetic-indexing circuit malfunction (sensor failed or magnet missing) or the stepping-motor is defective (or its driving IC on the main PCB). The PAN- movement is not located in the default position after the reset.

TILT- movement Er

(TILT-head movement error) This message will appear after the reset of the fixture if the head's magnetic-indexing circuit malfunctions (sensor failed or magnet missing) or the stepping-motor is defective (or its driving IC on the main PCB). The TILT- movement is not located in the default position after the reset.

Gobo wheel 1 Er

(Gobo wheel 1 - error) This message will appear after the reset of the fixture if the magnetic-indexing circuit malfunction (sensor failed or magnet missing) or the stepping-motor is defective (or its driving IC on the main PCB). The Gobo wheel 1 is not located in the default position after the reset.

Gobo Rot 1 Er

(Gobo Rot 1- error) This message will appear after the reset of the fixture if the magnetic-indexing circuit malfunction (sensor failed or magnet missing) or the stepping-motor is defective (or its driving IC on the main PCB). The Gobo Rot 1 is not located in the default position after the reset.

Effect Er

(Zoom-error) This message will appear after the reset of the fixture if the magnetic-indexing circuit malfunction (sensor failed or magnet missing) or the stepping-motor is defective (or its driving IC on the main PCB). The Effect is not located in the default position after the reset.

CLEANING AND MAINTENANCE

The following points have to be considered during the inspection:

1. All screws for installing the devices or parts of the device have to be tightly connected and must not be corroded.
2. There must not be any deformations on the housing, color lenses, fixations and installation spots (ceiling, suspension, trussing).
3. Mechanically moved parts must not show any traces of wearing and must not rotate with unbalances.
4. The electric power supply cables must not show any damage, material fatigue or sediments.

Further instructions depending on the installation spot and usage have to be adhered by a skilled installer and any safety problems have to be removed.

CAUTION



Disconnect from mains before starting maintenance operation.

We recommend a frequent cleaning of the device. Please use a moist, lint- free cloth. Never use alcohol or solvents.

There are no serviceable parts inside the device except for the lamp. Please refer to the instructions under "Installation instructions".

Should you need any spare parts, please order genuine parts from your local dealer.

TECHNICAL SPECIFICATIONS

Power supply: - AC 100V~ 50Hz; - AC 120V~ 50Hz; - AC 208V~ 50Hz;
- AC 220V~ 50Hz; - AC 230V~ 50Hz; - AC 240 V~ 50Hz;
- AC 100V~ 60Hz; - AC 120V~ 60Hz; - AC 208V~ 60Hz;
- AC 220V~ 60Hz; - AC 230V~ 60Hz; - AC 240 V~ 60Hz;

Power consumption: max. 400W

Lamp: Philips MSR GOLD 300 FASTFIT

Packing dimensions: 74x45.5x55cm

Net weight: 25.6KGS

Gross weight: 30.4KGS

Ballast type: - Magnetic ballast; - Electronic ballast

Remark: errors and omissions for every information given in this manual excepted. All information is subject to change without prior notice.



