

MOVING HEAD™

OBV-3

# User manual



**CAUTION!**

Risk of electric shock  
Read instructions before installing  
or connecting to power

# **contents**

<b>Features</b> .....	1
<b>Description of the appearance</b> .....	2
<b>Inspection</b> .....	3
<b>Safety instructions</b> .....	4
<b>Lamp Installation</b> .....	5
<b>Rigging</b> .....	6
<b>Connection with the mains</b> .....	7
<b>Linking</b> .....	7
<b>Instruction for gobo replacement</b> .....	8
<b>DMX Channel Chart</b> .....	9
<b>Control Board</b> .....	13
<b>Maintenance</b> .....	14
<b>Replacing the Fuse</b> .....	15
<b>Appendix A</b> .....	15
<b>Product Specifications</b> .....	16

## **Congratulations!**

Thank you for purchasing OBY Series that elaborate manufactured by Geni abundant experience of stage-lights. Hereafter you can get high quality and low breakdown products on the market from *Geni Electronics Co., Ltd.*; OBY Series concentrated unexpectedly lighting effects for animating stages.

If any question or suggestion you have, please offer the precious recommendation for improving our products and designs better; and create perspective and expectancy about future lighting.

# **Features**

## **Ideal & powerful effects**

- Smooth and silent revolving of a big range of 570-degree in X axis and 270-degree in Y axis, automatic electronic sensor to zero.
- 11 sharp dichroic colors + white.
- 6+1 easily replaceable rotating gobos.
- Various kinds of glass gobos are available for clients' choices.
- Rotating three facet prism.
- 1-7Hz fast flashing and 0-100% linear dimmer.
- Remote-controlled focus.
- Remote-controlled lamp switch ON/OFF.

## **Attractively smooth design**

- Stylish, high impact resistant polymer shell, which is lighter than any one else of the same class in the market.
- Solid square base is convenient set on the TRUSS, or directly stand on the ground or stage for uses.
- Systematic modular construction design has all inner function wheels and PCBs modularized, which allows version update or customization more convenient.
- Sophisticated optical system makes light output more bright and sharp.

## **Simple and easy operation**

- Standard USITT DMX512 protocol, 13 or 11 DMX Channel.
- High-torque stepper motors, smooth and precise micro-stepping control.
- LED screen controls DMX coding and built-in functions' election, as well as also display lamp's time usage.

# Description of the appearance



- 1. Projector-head
- 2. Yoke
- 3. Left side panel
- 4. Base
- 5. Control Board
- 6. Right side panel
- 7. Carrying handles

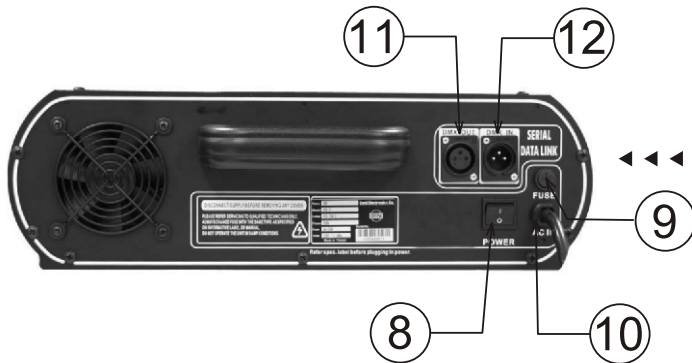

- Left side panel:*
- 8. Power-switch
  - 9. Fuse-holder
  - 10. Powercord
  - 11. DMX-output
  - 12. DMX-input



- Right side panel:*

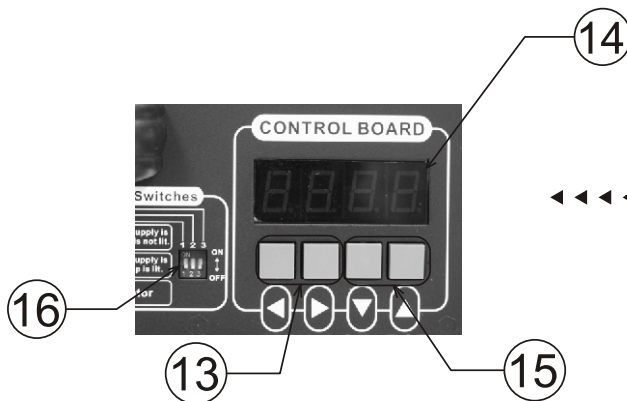

- Control Board:*
- 13. MENU (Function buttons)
  - 14. Display
  - 15. SELECT (ON/OFF or address number)
  - 16. DIP Switch

## **Inspection**

Carefully unpack the carton, and make sure if any damage or loss caused by transportation.

Contact your Geni dealer to assure your right by telephone or facsimile immediately if damage has occurred or if something is missing.

### **Packing List:**

**A. OBY-3 Moving Head**

**B. Operating Manual**

**C. Bracket**

**D. GOBO**

**E. Lamps (Optional)**

## **Safety instructions**

- This appliance must be earthed (grounded).
- Disconnect power before removing covers or servicing.
- Keep case closed while operating.
- OBY-3 contains no user serviceable parts. Refer servicing to qualified technicians only.
- Lamp and components become hot during operation. Allow time to cool before handling.
- Keep flammable material at least one meter away from unit.
- Do not operate in wet conditions or near liquids.
- Keep air vents clear to avoid overheating.
- Lamp produces hazardous UV light. Do not look directly at lamp when lit.
- Replace any blown or damaged fuses only with those of identical values.

## Lamp Installation

**! Warning !**  
Remove the power cord before installing the lamp.



Remove the power cord and set the unit as to the figure. Loosen the screws with appropriate tools and extract A. (See the figure.)



Loosen the screws with appropriate tools then extract B.



Please glove your hand to remove the lamp from the package in order to keep the lamp life. Insert the lamp in the lampholder securely and then put back B and A for the complete installation.

If you want to change the lamp, please extract the used lamp firstly, then execute the above-mentioned processes.

## **Rigging:**

Oby-3 can be set on the flat stage floor directly or use clamp to mount on any kinds of trusses for fitting the mobility of various venues.

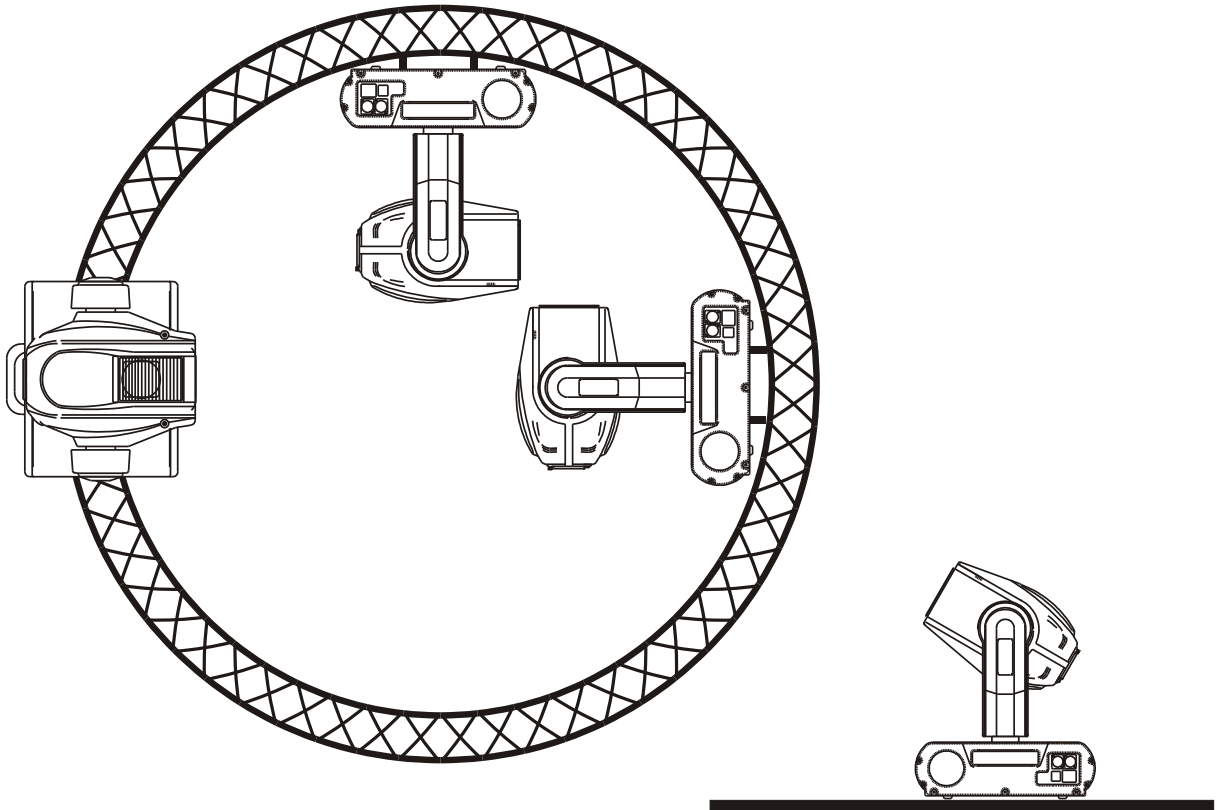

Mount two attached brackets(a) on the bottom (See Figure ), and collocate the appropriate clamps(b) to rig with trusses. Must use the safety ropes that can hold the ten times as heavy as the fixture through the eye bolts(c) on the bottom of the base and trusses; then join the safety ropes with screw-on carabines(d).

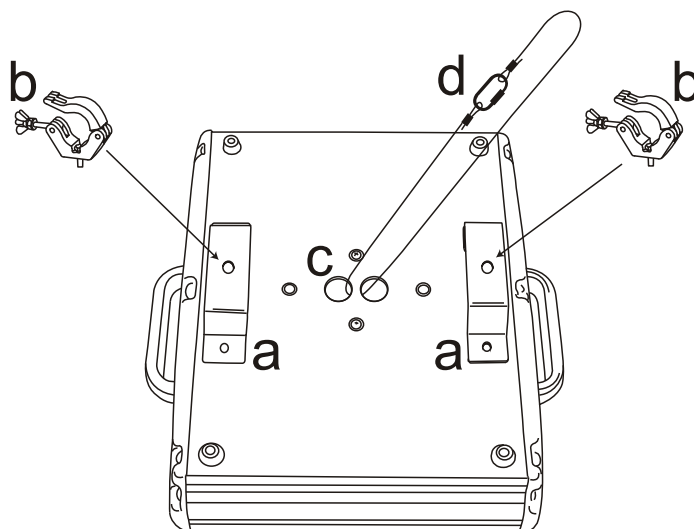



## Connection with the mains

Connect the device to the mains with the power-plug.  
*The occupation of the connection-cables is as follows:*

Cable	Pin	International
Brown	Live	L
Blue	Neutral	N
Yellow/Green	Earth	

The earth has to be connected! In general, lighting effects should not be connected to dimming-packs.

## Linking

Use 3-pin XLR data cables to link the controller to DMX lighting equipment.

**3-pin XLR connectors are follows:**

DMX-output  
XLR mounting-socket:

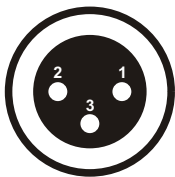

1:Ground  
2:Signal(-)  
3:Signal(+)

DMX-input  
XLR mounting-plug:

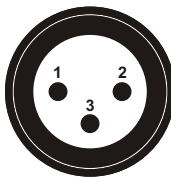

1:Ground  
2:Signal(-)  
3:Signal(+)

**Building a serial DMX-chain:**



Connect the DMX output of the first fixture with the DMX input of the next fixture. And execute all the setups following the above-mentioned instruction.

Flip the DIP SWITCH #3 of last fixture to ON position for terminal confirmation.

## Instructions for gobo replacement



Please choose the suitable gobo dimensions of this fixture. (Appendix A)

### Rotating GOBO wheel

1. Loosen the arrow-indicated screws in order with appropriate tools.

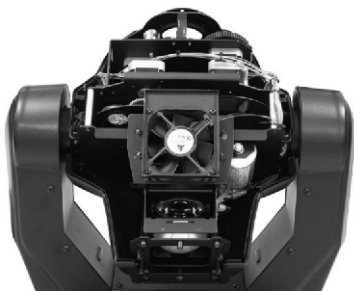
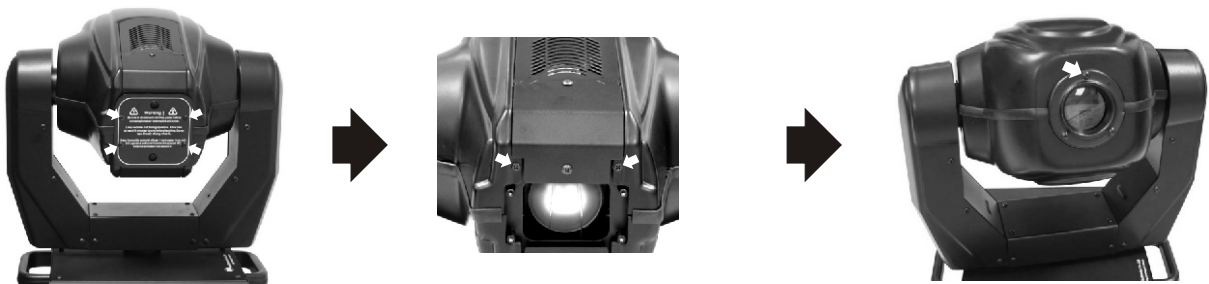

2. Open the top cover.



3. Push GOBO & the spring ring out with the fingers carefully. (\*Caution: Avoid falling the spring ring into the fixture.)

4. Insert the new GOBO and the spring ring (\*Press the spring ring tight with the appropriate tools in order to keep GOBO compact), screw up the top cover.

# DMX Channel chart

## Function of the control channels - 16 bit protocol

### Channel 1 - Dimmer intensity

<b>CH 1</b> Dimmer	
0-255	Gradual adjustment of the dimmer intensity from 0 to 100 %









### Channel 2 - Shutter, Strobe

<b>CH 2</b> Shut	
0-7	Shutter closed
8-255	Strobe-effect from slow to fast (max. 7 flashes/second)



### Channel 3 - Colorwheel 1

<b>CH 3</b> Color	0-13	14-27	28-41	42-55	56-69	70-83	84-97	98-111	112-125	126-139	140-153	154-167	168-255
	0 - 13	14 - 27	28 - 41	42 - 55	56 - 69	70 - 83	84 - 97	98 - 111	112 - 125	126 - 139	140 - 153	154 - 167	168 - 255
	Open/white	Steel Blue	Orange	Green Blue	Bright Blue	Bright Pink	Red	Deep Blue	Yellow	Dark Pink	Moss Green	Light Blue	Color wheel rotation slow to fast

## Channel 4 - Rotating gobo wheel



<b>CH 4</b> Gobo	0-23 	24-47 	48-71 	72-95 	96-119 	120-143 	144-167 	168-255 
---------------------	---	--	--	--	---	--	--	--

## Channel 5 - indexing & Rotating gobo rotation

<b>CH 5</b> Gobo Rotate	0 0°	Gobo Angle	127 360°	128	Rotate Clockwise	191	192	Rotate Counterclockwise	255
				Low Speed		High Speed	High Speed		Low Speed

- 0 – 127 Rotating gobo angle adjustment from zero to 360 degrees.
- 128 – 191 Forwards gobo rotation from fast to slow
- 192 – 255 Backwards gobo rotation from slow to fast

## Channel 6 - Prism-wheel

<b>CH 6</b> Prism & Rotate	0	1	2	7	8	Rotate Clockwise	132	133	Rotate Counterclockwise	253	254 - 255
	Single Gobo	Triple Prism Static		Low Speed			High Speed	High Speed		Low Speed	Triple Prism Static

- 0 – 1 Open position
- 2 – 7 Triple prism static
- 8 – 132 Triple prism forwards rotation from fast to slow
- 133 – 253 Triple prism backwards rotation from slow to fast
- 254 – 255 Triple prism static

## Channel 7 - Focus

<b>CH 7</b> Focus	0 	127 	255 
----------------------	--	--	--

- 0 – 255 Focus adjustment from near to far

## Channel 8 - Pan reguration

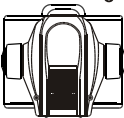
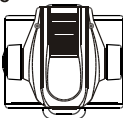
<b>CH 8</b> Pan Cors.	0 0° 	Pan Adjustment	255 570° 
--------------------------	--	----------------	--

- CH-11 The “head” of the unit is allowed to turn horizontally from zero to 570 degrees.

## Channel 9 Tilt reuration

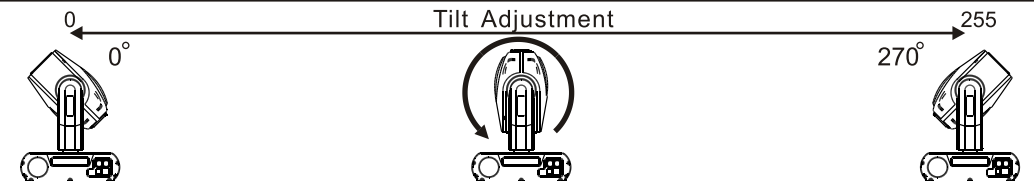
<b>CH 9</b> Tilt Cors.	 <p>The diagram illustrates the tilt adjustment range. It shows three views of the unit's head: one at 0° (pointing left), one in the center with a circular arrow indicating rotation, and one at 270° (pointing right). A horizontal line above the views is labeled 'Tilt Adjustment' with arrows pointing from 0 to 255. The 270° position is also labeled as 255.</p>
<p>The “head” of the unit is allowed to turn vertically from zero to 270 degrees</p>	

## Channel 10 Pan fine-tune

<b>CH 10</b> Pan Fine	<p>While rotating horizontally the “head” is allowed to be fine tuned from zero to 2.2 degrees.</p>
--------------------------	---

## Channel 11 Tilt fine-tune

<b>CH 11</b> Tilt Fine	<p>While rotating vertically the “head” is allowed to be fine tuned from zero to 1 degree.</p>
---------------------------	--

## Channel 12-Reset

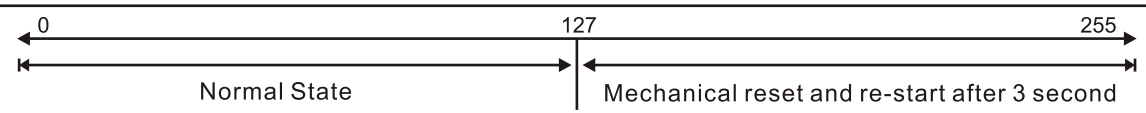
<b>CH 12</b> Reset	 <p>The diagram shows two horizontal arrows representing reset ranges. The first arrow starts at 0 and ends at 127, labeled 'Normal State'. The second arrow starts at 127 and ends at 255, labeled 'Mechanical reset and re-start after 3 second'.</p>
<p>0 – 127 Normal state 127 – 255 Mechanical reset and re-start after 3 seconds</p>	

## Channel 13-Lamp switch

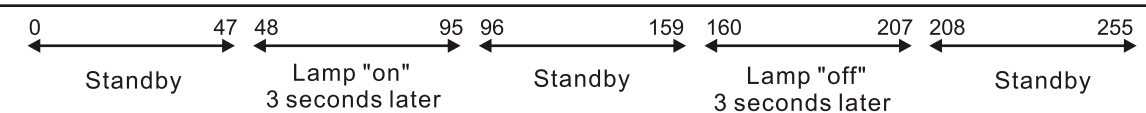
<b>CH 13</b> Lamp SW	 <p>The diagram shows five horizontal arrows representing lamp switch states. The first arrow (0-47) is labeled 'Standby'. The second arrow (48-95) is labeled 'Lamp "on" 3 seconds later'. The third arrow (96-159) is labeled 'Standby'. The fourth arrow (160-207) is labeled 'Lamp "off" 3 seconds later'. The fifth arrow (208-255) is labeled 'Standby'.</p>
<p>0 – 47 Standby 48 – 95 Lamp "on" 3 seconds later 96 – 159 Standby 160 – 207 Lamp "off" 3 seconds later 208 – 255 Standby</p>	

***Function of the control channels - 8 bit protocol***

DMX Channel	Function
1	DIMMER
2	SHUT
3	COLOR
4	GOBO
5	GOBO ROTATE
6	PRISM AND ROTATE
7	FOCUS
8	PAN COARSE
9	TILT COARSE
10	AUTO RESET
11	LAMP ON/OFF

## Control Board



<i>Addr</i>	Press ▲ to increase DMX Address; ▼ to decrease. Press ▲▼ simultaneously to zero DMX address.
<i>LP.T</i>	Used lamp time Press ▲▼ simultaneously to zero lamp time , unit: hour
<i>Shut</i>	Off : Normal On: Shutter closes during changing color 、 gobo or prism. Shutter opens after color 、 gobo and prism are properly positioned.
<i>Colo</i>	Off: Color wheel linear movement On: Color wheel fixed step advance
<i>Focu</i>	Off: Normal On: Focus adjustment
<i>r.PAn</i>	X-axis- Off: left to right On: right to left
<i>r.tilt</i>	Y-axis- Off: down to up On: up to down
<i>l.b.br</i>	Off: 8bit control model On: 16bit control model
<i>dENo</i>	Off: Normal On: Self-demonstration
<i>SoFT</i>	Off: Quick paced function demonstration. On: Slow paced function demonstration.
<i>dP.SE</i>	Off: Display off ; On: Display on While 'Off ', press any key to turn on the display
<i>r.SEt</i>	Off: Normal On: Self-zero all motors once
<i>dF.SE</i>	Off: Normal On: Reset the unit as ex-works. Default returns to "OFF" position.
<i>LAMP</i>	Off:Lamp off On:Lamp on

- ⊙ Press ◀▶ simultaneously returning to " Addr ".
- ⊙ Press ◀▶ simultaneously in advance before switching on the unit, release ◀▶ to erase all recorded data after switching the unit as ex-works.
- ⊙ Once operation stopped, the unit stores all data. When restarting the unit, it starts with the latest play of last operation before turning off the unit.

## **Maintenance**

Refer maintenance to qualified technicians. Please disconnect power and signal wire before maintaining fixtures.

In order to preserve OBY-3 in good condition, keep the routine maintenance by following date.

The Steps are as follows:

- The dichroic colour-filters, the metal gobo-wheel, the internal lenses and cooling fans should be cleaned with soft brush monthly.
- The interior of the fixture should be cleaned at least half-yearly using a vacuum-cleaner or an air-jet.  
**Caution: Be careful not to damage the interior mechanical structures or circuits when using the air-jet.**
- To ensure a proper function and smooth rotation of the gobo-wheel, we recommend lubrication in six-month intervals.  
**Caution: Avoid the damage of interior structures when fixtures rotated, do not use excess lubrication.**

Due to emit fog frequently, the optical lens and gobos would be oily; thus luminosity would be weak. We recommend using moist cloth or a trace of detergents to wipe them every two weeks. (Prohibit using the detergents consisted of alcohol and solvents.)



## **Replacing the Fuse**

If the fixture does not function, that may be the fuse was burned out. It may be time to replace the fuse of same type and specification for eliminating this fault.

Remove the electric power and flip the switch to " off " position before replacing the fuse.

Replace the fuse as follows:

Step 1: Unscrew the screw of the fuse holder on the housing counterclockwise with appropriate tools.

Step 2: Remove the broken fuse and then replace the new fuse.

Step 3: Reinsert and tighten the screw on the fuse-holder.

Step 4: Turn the power on for test.

Please contact with the dealer if the fixture still cannot work or the fuse burns out again.

## **Appendix A**

### GOBO Size

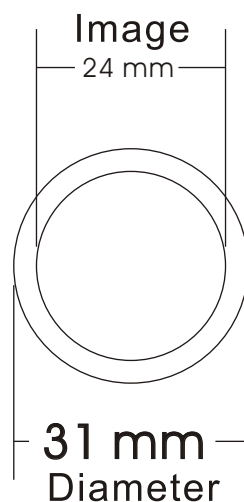

# Product Specifications

---

## **Construction**

Housing: High impact resistant polymer cover  
Colors: Black or white  
Metal finish: Electrostatic powder coating

---

## **Physical**

Dimension (L x W x H); 400 x 380 x 540 mm  
Weight: 24 kg

---

## **AC supply**

AC input: Certified power cord with plug or without plug  
Voltage: 100V, 120V, 220V, 230V, 240V 50/60Hz  
Fuse: 120V: 8A. 230V: 5A  
Power Consumption: 350VA

---

## **Control and programming**

Signal pin out: pin 1 shield, pin 2 (-), pin 3 (+)  
Setting and addressing: LED control pane)  
Protocol: USITT DMX-512  
Pan/tilt resolution: 8 or 16 bit  
DMX channels: 11-13  
Signal input: 3-pin XLR male  
Signal output: 3-pin XLR female

---

## **Source**

Lamp: 250 W discharge  
Base: GY9.5  
Approved models: Philips MSD-250/2 (2000 hr; 8500K)  
Philips MSD-250 (2000 hr; 6700K)  
Osram HSD-250/2 (2000 hr; 7800K)  
Osram HSD-250 (2000 hr; 6000K)  
Control: Automatic and DMX remote on/off

---

## **Electromechanical effects**

Color wheel : 11 dichroic colors + white  
Rotating gobo wheel: 6 replaceable gobos + white  
Gobo rotation: adjustable speed and direction  
Dimmer: 0-100 linear dimmer  
Strobe: 1-7Hz fast flashing  
Rotating 3-facet prism: in/out variable speed and direction

Focus: 2m - infinity  
Pan: 0°-570°  
Tilt: 0°-270°  
Wheel control: auto-electronic reset

---

## **Gobos**

Metal gobo: Diameter: 31 mm  
Maximum image diameter: 25 mm  
Metal type: white iron  
Glass gobo; Diameter: 31 mm  
Maximum image diameter: 25 mm  
Glass type: heat-resistant and intensify glass  
Glass coating; dichroic

---

## **Accessories**

Half-coupler clamp

---

