

Giotto spot 400 CMY

Professional Moving head



User's Manual rel. 1.0

General instructions

Read the instructions in this handbook carefully, as they give important information regarding safety during installation, use and maintenance.

Be sure to keep this instruction manual with the fixture, in order to consult it in the future. If the fixture is sold or given to another operator, make certain he or she also receives the manual, to be able to read about its operation and follow the relative instructions.



- THIS UNIT IS NOT FOR HOME USE, ONLY PROFESSIONAL APPLICATIONS
- AFTER HAVING REMOVED THE PACKAGING, CHECK THAT THE FIXTURE IS NOT DAMAGED IN ANY WAY. IF IN DOUBT, DON'T USE IT AND CONTACT AN AUTHORIZED SGM TECHNICAL SERVICE CENTRE.
- PACKAGING MATERIAL (PLASTIC BAGS, POLYSTYRENE FOAM, NAILS, ETC.) MUST NOT BE LEFT WITHIN CHILDREN'S REACH, AS IT CAN BE DANGEROUS.
- THIS FIXTURE MUST ONLY BE OPERATED BY ADULTS. DO NOT ALLOW CHILDREN TO TAMPER OR PLAY WITH IT.
- ELECTRICAL WORK NECESSARY FOR INSTALLING THE FIXTURE MUST BE CARRIED OUT BY A QUALIFIED ELECTRICIAN OR EXPERIENCED PERSON.



- NEVER USE THE FIXTURE UNDER THE FOLLOWING CONDITIONS:
 - IN PLACES SUBJECT TO EXCESSIVE HUMIDITY
 - IN PLACES SUBJECT TO VIBRATIONS OR BUMPS.
 - IN PLACES WITH A TEMPERATURE OF OVER 45°C OR LESS THAN 2°C
- PROTECT THE FIXTURE FROM EXCESSIVE DRYNESS OR HUMIDITY (IDEAL CONDITIONS ARE BETWEEN 35% AND 80%).
- DO NOT DISMANTLE OR MODIFY THE FIXTURE.



- MAKE CERTAIN THAT NO INFLAMMABLE LIQUIDS, WATER OR METAL OBJECTS ENTER THE FIXTURE.
- THE MINIMUM DISTANCE BETWEEN THE FIXTURE AND THE SURFACE TO BE LIT MUST BE NO LESS THAN 1.5 METRES
- SHOULD ANY LIQUID BE SPILLED ON THE FIXTURE, DISCONNECTED THE POWER SUPPLY TO THE FIXTURE IMMEDIATELY.
- IN THE EVENT OF SERIOUS OPERATING PROBLEMS, STOP USING THE FIXTURE IMMEDIATELY AND EITHER CONTACT THE NEAREST SGM SALES POINT FOR A CHECK OR CONTACT THE MANUFACTURER DIRECTLY.
- DO NOT OPEN THE FIXTURE - THERE ARE NO USER SERVICEABLE PARTS INSIDE.



- NEVER TRY TO REPAIR THE FIXTURE YOURSELF. REPAIRS BY UNQUALIFIED PEOPLE COULD CAUSE DAMAGE OR FAULTY OPERATION. CONTACT YOUR NEAREST AUTHORIZED SERVICE CENTRE.
- WHEN CARRYING OUT ANY WORK, ALWAYS COMPLY SCRUPULOUSLY WITH ALL THE NORMS (PARTICULARLY REGARDING SAFETY) CURRENTLY IN FORCE IN THE COUNTRY IN WHICH THE FIXTURE'S BEING USED.
- Do not place the unit on inflammable parts or material

Always insist on original spare parts being fitted.

General warranty conditions

- THE UNIT IS GUARANTEED FOR 24 MONTHS FROM THE DATE OF PURCHASE AGAINST MANUFACTURING MATERIAL DEFECTS. BREAKDOWN CAUSED BY CARELESSNESS AND IMPROPER USE OF THE FIXTURE IS EXCLUDED.
- THE GUARANTEE IS NO LONGER VALID IF THE UNIT HAS BEEN TAMPERED WITH OR REPAIRED BY UNAUTHORIZED PERSONNEL. REPLACEMENT OF THE FIXTURE IS NOT FORESEEN BY THE GUARANTEE.
- EXTERNAL PARTS, KNOBS, SWITCHES, REMOVABLE PARTS AND LAMPS ARE EXCLUDED FROM THE GUARANTEE: THESE ARE COVERED BY THEIR MANUFACTURERS' GUARANTEE CONDITIONS.
- TRANSPORT COSTS AND RELATED RISKS ARE BORNE BY THE FIXTURE'S OWNER.
- THE GUARANTEE IS VALID TO ALL EFFECTS ONLY ON PRESENTATION OF THE GUARANTEE CERTIFICATE TO THE MANUFACTURER OR THE NEAREST SGM TECHNICAL ASSISTANCE CENTRE.
- ALWAYS QUOTE THE UNIT'S SERIAL NUMBER AND MODEL WHEN CONTACTING YOUR RESELLER FOR INFORMATION OR ASSISTANCE.

Protect the environment: don't throw packing material into your garbage can return it to your SGM retailer or take it to the nearest special waste collection point.

index

GENERAL WARNINGS AND INSTRUCTIONS	1
GUARANTEE CONDITIONS	1
PRESENTATION	3
MAIN FEATURES	4
ACCESSORIES	5
SYMBOLS USED	5
ELECTRICAL SPECIFICATIONS	6
MECHANICAL FEATURES	6
1 INSTALLATION	7
1.2 ACCESS TO INTERNAL COMPONENTS	8
1.3 INSTALLING THE LAMP	9
1.4 LAMP ALIGNMENT	9
1.5 INSTALLING /REPLACING GOBOS	10
1.6 FITTING/REMOVAL ANIMATION WHEEL	10
1.7 INSTALLING /REPLACING COLOR FILTERS	12
1.8 CONSTRUCTING A POWER CORD	12
1.9 GIOTTO SPOT'S POWER SUPPLY	12
1.91 MOUNTING THE FIXTURE ON TRUSSING OR SIMILAR STRUCTURES	12
1.92 POSITIONING THE FIXTURE	13
1.93 INSTALLING THE CLAMPS	13
2 SIGNAL CABLE	14
2.1 DMX TERMINATION PLUG CONSTRUCTION	14
2.2 RS-232 CONNECTION	15
2.3 UPGRADING THE FIXTURE'S FIRMWARE	15
3 "CONTROL" MICROCOMPUTER	16
3.1 MENU NAVIGATION	16
3.2 ALLOCATING THE START CHANNEL (ADDRESSING)	18
3.3 PAN DIRECTION	18
3.31 LIMITING PAN	18
3.4 TILT DIRECTION	19
3.41 LIMITING TILT	19
3.5 INVERTING PAN/TILT	19
3.6 LAMP ELAPSED TIME COUNTER	19
3.61 RESETTING THE LAMP ELAPSED TIME COUNTER	19
3.7 LAMP STRIKE (IGNITION) COUNTER	20
3.71 RESETTING THE LAMP STRIKE COUNTER	20
3.8 FIXTURE OPERATING TIME COUNTER	20
3.9 INPUT SIGNAL	20
3.10 PAN/TILT MOVEMENT RESOLUTION	20
3.11 REMOTE CONTROLLED LAMP STRIKE (IGNITION)	20
3.12 REMOTE CONTROLLED FIXTURE RESET	21
3.13 CONTROLLING ACCELERATION AND SPEED	21
3.14 DISPLAY BRIGHTNESS	21
3.15 DISPLAY VIEWING POSITION	21
3.16 DMXDLY	21
3.17 LOCKING/UNLOCKING THE SHUTTER	22
3.18 SETTING DEFAULT PARAMETERS	22
3.19 RESTORING DEFAULT PARAMETERS	22
3.20 SETTING THE STARTING POSITION OF THE ROTATING GOBOS AND THE GOBO, COLORS,	22
3.21 TEST FUNCTIONS	23
3.22 RESERVED FUNCTIONS	23

Presentation

Giotto Spot cmy is SGM's innovative professional moving head spot, specifically manufactured for use in high profile shows, theatres, Television studios and entertainment venues in general.

Thanks to its cutting edge performance, the result of SGM's lengthy experience in mechanical and electronic design, Giotto Spot is one of the world's best.

Its use of an MSD 400HR discharge lamp and a perfect optical system makes it one of the best fixtures currently on the market.



***Made in Italy by SGM Technology for Lighting
Printed in December 2004 Rel. 1.00***

Main features

Lamp

Giotto Spots use a Philips MSD 400HR (6000°K) discharge lamp.

Effects

- Linear zoom (9° - 22°)
- Fast linear iris
- Automatic electronic focus
- Linear dimmer (0-100%)
- Shutter / strobe 12 fps with music sync
- 2 gobo wheel
- 1 Colour wheel with 6 positions + white, supplied as standard with 8 dichroic colours
- Advanced CMY colour mixing.
- Animation wheel.
- Variable speed gobo scrolling
- Gobo shake
- Rainbow effect on gobo wheel.
- Color change and gobo change with blackout
- Color change and gobo change with music sync
- 2-tone beam, analog color selection, 16-speed rainbow
- 1 4-facet rotating prism with adjustable speed in both directions
- Linear variable frost filter: from soft-edge to full-wash
- Linear CTO filter
- Automatic re-positioning with black-out
- Macros

Movement

- 540° Pan (2.8sec.) and 240° Tilt (1.7sec.)
- 8/16 bit movement resolution
- Automatic re-positioning in the event of accidental head movement
- Possibility of inverting Pan and Tilt movement
- Possibility of limiting Pan and Tilt range
- Variable acceleration and speed parameters

Electronic Ballast

Supplied as standard with every fixture

- Automatic universal power supply acceptance: 90-245V 50,60Hz
- Flicker-free
- Lamp power reduction in the event of fixture overheating
- Power Factor Correction
- Automatic energy saving in the event of beam black-out
- Hot re-strike.

Optics

- High luminous efficiency Optics
- Linear beam projection angle variation (9° - 22°)
- Motorized focus

Display/Microcomputer

- The fixture can be "customized" according to type of installation: function tests available for each effect; Lamp On/Off via DMX can be enabled; Fixture reset via DMX can be enabled; fixture addressing; display "flip" function (rotates through 180°); adjustable display brightness and more.
- Info displayed includes: lamp elapsed time and strike counters, fixture operating time counter, software version supported.

Control signal

Input signal DMX 512 - RS 232

Mounting System

- "Fast-Lock" clamps supplied as standard with fixture
- Several clamp mounting points to enable the fixture to be mounted on any type of truss
- Safety chain/cable mounting points

Accessories

- Single flight case
- Double flight case

cod:0061745
cod:0061746



Symbols used



THIS SYMBOL INDICATES A GENERAL RISK

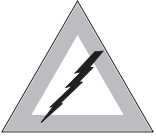

THIS SYMBOL INDICATES ELECTRIC SHOCK RISK



THIS SYMBOL INDICATES A HOT SURFACE



THIS SYMBOL MEANS "DO NOT PLACE THE UNIT ON INFLAMMABLE PARTS OR MATERIAL"

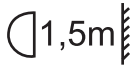

THIS SYMBOL INDICATES THAT THE MINIMUM DISTANCE BETWEEN THE FIXTURE AND THE SURFACE TO BE LIT MUST BE NO LESS THAN 1.5 METRES

ELECTRICAL SPECIFICATIONS



DANGER!! CLASS 1 FIXTURE. THIS UNIT MUST BE GROUNDED

POWER REQUIREMENTS: UNIVERSAL 90V-245 V 50Hz,60Hz.

POWER ABSORBED: 520W

FUSED 2PZ - 8A CT

LAMP SPECIFICATIONS

LAMP:	MSD 400HR
LUMINOUS EFFICACY	80 LM/W
COLOR COORDINATES	X,Y 328,323
COLOR TEMPERATURE	6000°K
LUMINOUS FLUX:	32000 LUMENS
AVERAGE LIFE (50%)	750 HR.
CAP/BASE	Gzz9,5

OPTICAL SYSTEM:

INTERNAL OPTICAL GROUP COMPRISING HIGH LUMINOUS EFFICIENCY DICHROIC REFLECTOR; LINEAR BEAM ANGLE ADJUSTMENT (9° - 22°) ELECTRONIC FOCUS.

METAL GOBO

DIAMETER:	30MM
IMAGE AREA:	24MM

DICHROIC GOBO

DIAMETER:	28MM
IMAGE AREA:	24MM
THICKNESS	1,1MM

COLOR FILTER

DIAMETER:	34MM
THICKNESS:	1,1MM

SETTING: VIA BUILT-IN MICRO-COMPUTER

CONTROL SIGNAL: USITT DMX 512 OR RS-232 CONTROL

CHANNELS REQUIRED: 32

Mechanical Features

BODY: STRUCTURE IN CAST ALUMINIUM, CASING IN MOULDED TERMOPLAST

WEIGHT: 33 KG.

DIMENSIONS (MM.)

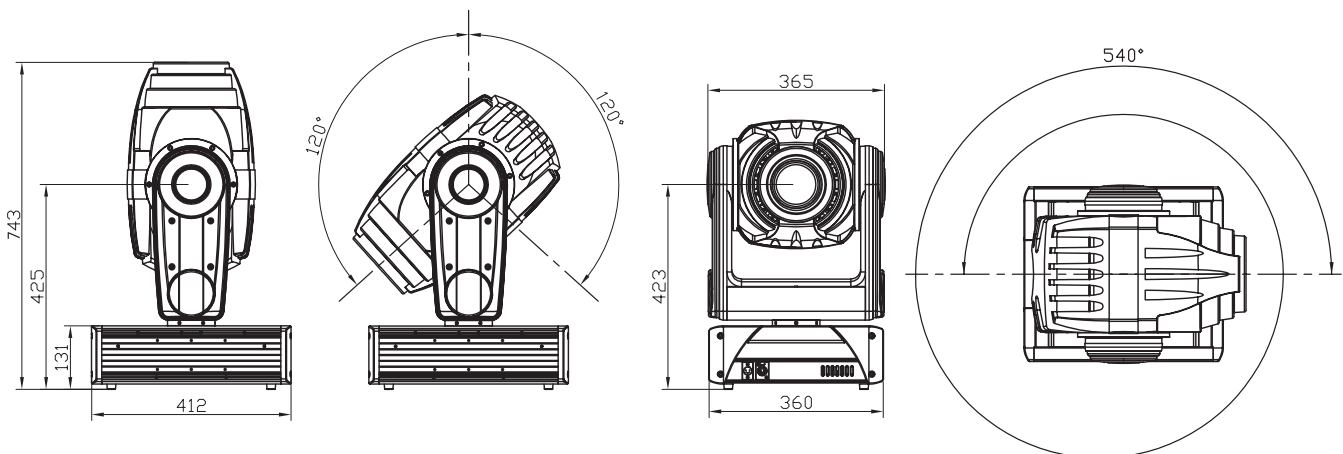

**SGM Elettronica reserves the right to improve or modify its products at any time.
Always refer to the manual supplied with the unit to
avoid any risk of mistakes or operation which
does not correspond to manual indications.**

Changes to this manual

SGM has an on-going product development policy, so the information printed in this manual may not be completely up to date. If any doubts arise regarding the topics covered in this manual or should any further help be required, our online services (internet-server www.sgm.it) are available 24 hours a day. In the FAQ section of the technical assistance zona, answers can be found to numerous common queries: fixtures, firmware and manuals can also be downloaded whenever required.



Items supplied

Before proceeding with fixture installation, make certain that the packing contains all the items shown in the following list and ensure that the fixture is undamaged.

If in doubt, don't use the fixture and contact an authorized SGM technical assistance centre and the freight company.

In fact, only the recipient can claim for any damage caused to the fixture during transport.

- GIOTTO SPOT 400 CMY
- WARRANTY
- INSTRUCTION MANUAL
- 1 MALE XLR 5 P CONNECTOR
- 1 FEMALE XLR 5 P CONNECTOR
- 1 POWER-CON CONNECTOR
- 2 FAST-LOCK CLAMPS
- 1 SAFETY CABLE

KEEP THE PACKING MATERIAL.

PACKING MATERIAL (PLASTIC BAGS, POLYSTYRENE FOAM, NAILS, ETC.) IS POTENTIALLY HAZARDOUS, SO MUST NEVER BE LEFT WITHIN CHILDREN'S REACH. USE THE ORIGINAL PACKING IN THE EVENT OF HAVING TO RETURN THE FIXTURE TO THE MANUFACTURER FOR REPAIR OR MAINTENANCE: IT'S BEEN DESIGNED SPECIFICALLY TO PROTECT THE FIXTURE DURING TRANSPORT.

1.2 Access to internal components

Giotto fixtures have a simple head opening mechanism.

All work must ALWAYS be carried out by qualified technical personnel.



ATTENTION: make certain that the fixture is switched off and that there is no risk of burns due to high component temperature (wait at least 30 minutes after switching off)

To access internal components, proceed as follows:

1. Loosen the two screws shown in Fig.1, Fig. 2 on both sides of the fixture
2. Remove the cover in the direction indicated by the arrow (Fig. 3)



Fig. 1



Fig. 2

3. Unscrew the two threaded pins (1)(2) as shown in Fig.4
4. Swivel the whole block downwards (Fig. 5)

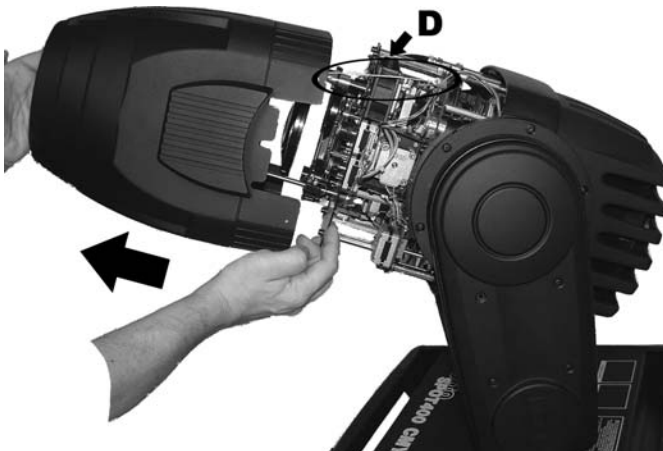

Fig. 3

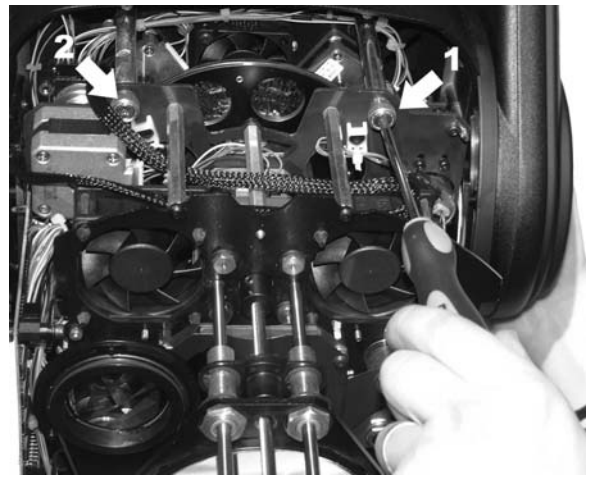

Fig. 4



Fig. 5

1.3 Installing the lamp



ATTENTION! This fixture is designed exclusively for use with Philips MSD 400HR lamps. NEVER USE ANY OTHER TYPES OF LAMPS.



- DISCONNECT THE POWER SUPPLY BEFORE CARRYING OUT ANY WORK ON THE FIXTURE.
- MAKE CERTAIN THAT THE FIXTURE IS OFF AND THE TEMPERATURE OF THE COMPONENTS CAN'T CAUSE BURNS (WAIT AT LEAST 30 MINUTES AFTER SWITCHING OFF).
- NEVER CARRY OUT ANY WORK IF THE FIXTURE DOESN'T HAVE ITS PROTECTIVE COVERS OR ITS LENSES ARE DAMAGED. DISCHARGE LAMPS CAN EXPLODE.
- NEVER LOOK DIRECTLY AT THE LAMP WHEN IT'S LIT - DISCHARGE LAMPS EMIT UV RAYS WHICH ARE DANGEROUS FOR SIGHT.



Inside the fixture's moving head, there is an optical system. Follow the following instructions when installing a lamp or relamping.

1. Disconnect the power supply, put on protective gloves and eyewear.
2. Open the fixture (see paragraph 1.2) and fit the lamp as shown in figures 4, 5, 6 and 7



Fig. 4



Fig. 5



ATTENTION!! When fitting a lamp, always use gloves or soft lint-free cloth - never touch it with your bare hands.



Fig. 6

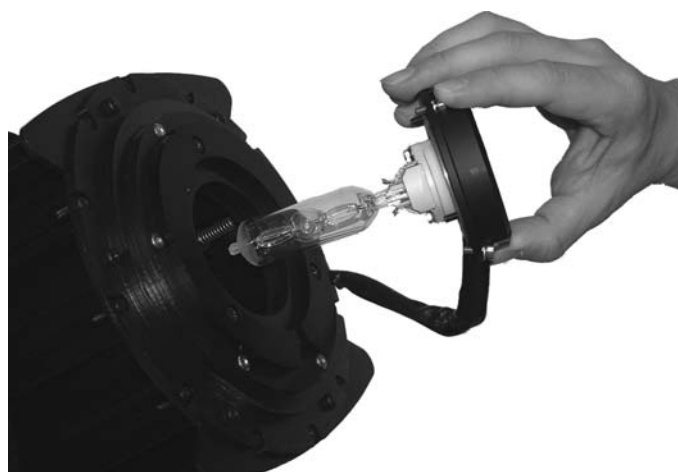

Fig. 7

1.4 Lamp alignment

Every time a new lamp is installed in the fixture, it must be aligned with the optical system to ensure optimum even light output from the unit.

1. Install the new lamp (par. 1.3), close the fixture and switch it on
2. Connect the fixture to a lighting console.
3. Point the fixture at a flat surface (if possible white or light colored) at least three metres from the fixture.
4. Set the control channels to obtain a white beam. Then open the IRIS, set the DIMMER fully open, FOCUS correctly and do NOT project GOBOS or COLORS.
6. Use screws 1, 2 and-3 to align the lamp until an evenly projected light beam is obtained, with no shadows or zones which are brighter than others.



1.5 Installing /replacing gobos

Metal: After opening the fixture, locate the gobo to be replaced, press delicately downwards (Fig.1) until the spring and the gobo come out, making sure they don't fall inside the fixture. Install the new gobo (1) as shown (Fig.2), followed by the locking spring (2).

Dichro: After opening the fixture, locate the gobo to be replaced, press delicately downwards (Fig.1) until the spring, ring and the gobo come out, making sure they don't fall inside the fixture. Install the new gobo (3) as shown (Fig.2), followed by the ring (4) and the locking spring (5).

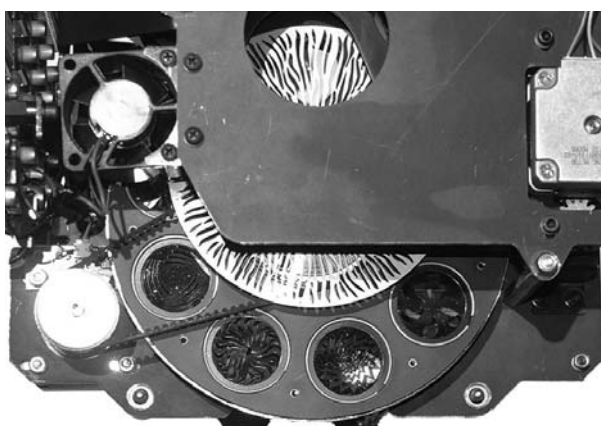

Fig.1

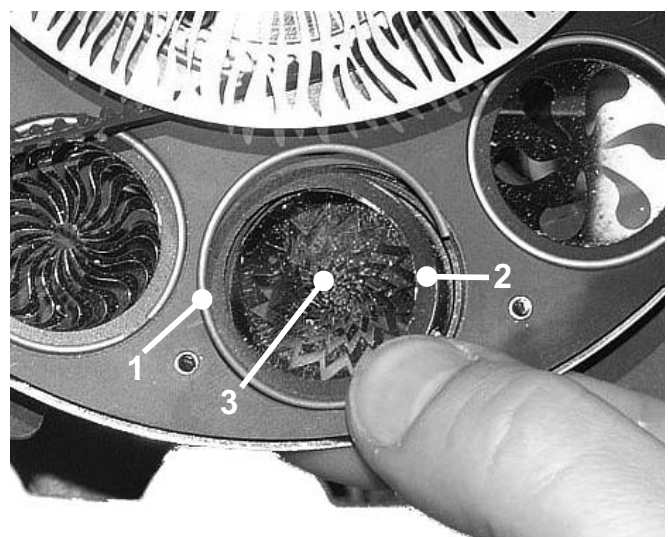

Fig 2



1.6 Fitting/removal Animation wheel

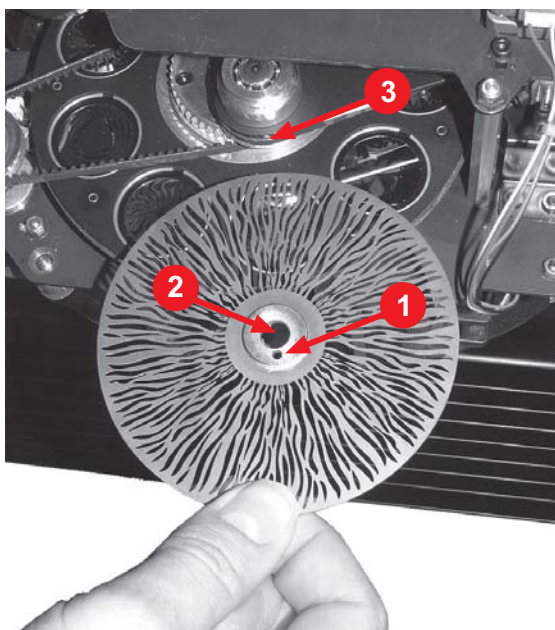

Fig.1

REMOVAL: Grip the Animation Wheel with both hands, pushing slightly downwards and at the same time pulling outwards (see the arrows in Fig. B) 2)

FITTING: Carry out the same procedure in the opposite order, making sure to align the hole (Fig 1) with the pin.

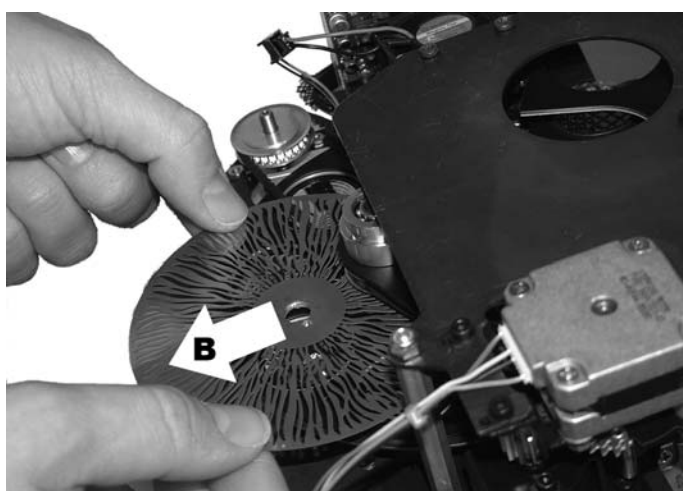
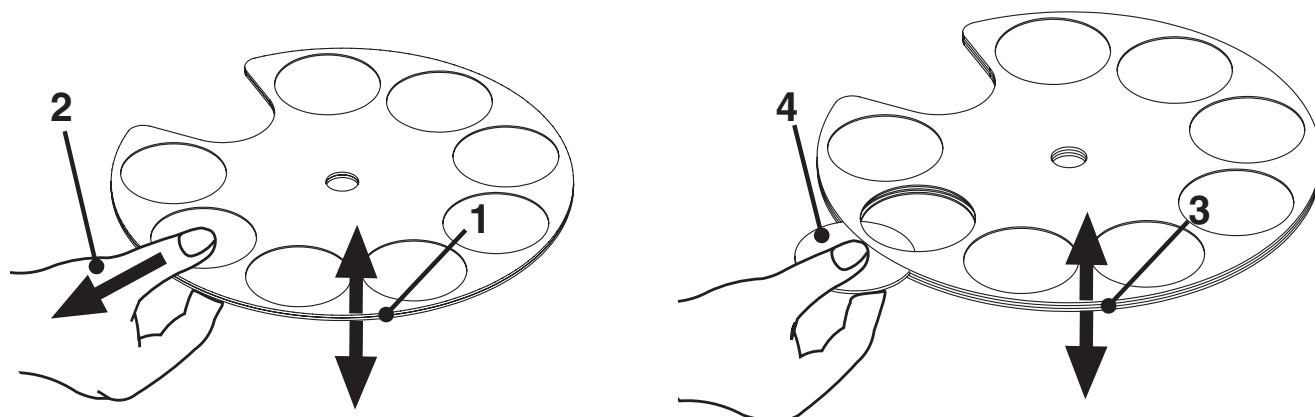

Fig. 2

1.7 Installing /replacing color filters

Choose which of the wheel's dichroic filters is to be replaced, grip it firmly between your fingers, carefully widen the discs (1), slide the filter out in the direction indicated by the arrow (2). Carefully widen the discs again (3) and slide the new filter in (4) until it fits into its engraved slot.



1.8 Power cable construction



DANGER! ELECTRICAL SHOCK HAZARD

- ELECTRICAL WORK NECESSARY FOR INSTALLING THE FIXTURE MUST BE CARRIED OUT BY A QUALIFIED PERSON.
- CLASS 1 DEVICE, THE FIXTURE MUST BE SUITABLY EARTHED.

The POWER-CON type connector supplied along with the Giotto is indispensable for connecting the fixture to the power supply. The following design shows how to connect the connector to the cable, whereas the table shows the symbols normally used to indicate connections.

When in doubt, consult a qualified electrician.

CABLES	PIN	TYPICAL	US	UK
Brown	Phase	"L"	Yellow/Copper	Red
Blue	Neutral	"N"	Silver	Black
Yellow/Green	Ground		Green	Green

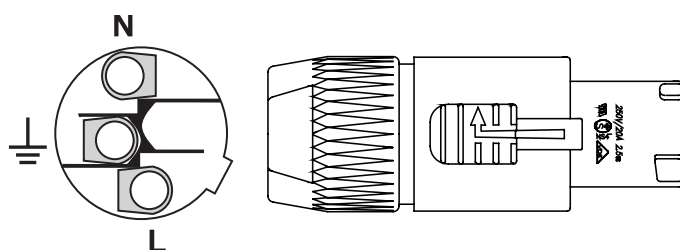

1.9 - Giotto Spot's power supply



ATTENTION!!

- DON'T POWER THE GIOTTO WITH A DIMMER CIRCUIT - THIS COULD DAMAGE THE ELECTRONIC BALLAST.
- BEFORE CONNECTING THE FIXTURE, MAKE CERTAIN THAT THE DATA ON THE FIXTURE'S PLATE CORRESPOND WITH THOSE OF THE LOCAL MAIN POWER SUPPLY.
- THE FIXTURE MUST BE CONNECTED TO A CUT-OFF CIRCUIT.

1.91- Installing the fixture on a support structure

READ THE FOLLOWING SAFETY INFORMATION BEFORE PROCEEDING WITH THE INSTALLATION OF THE FIXTURE:



- FIXTURE NOT FOR DOMESTIC USE.
- DO NOT INSTALL THE FIXTURE NEAR SOURCES OF HEAT.
- INSTALL THE FIXTURE IN A WELL VENTILATED PLACE.
- AVOID BLOCKING AIR INTAKES AND OUTPUTS.
- DO NOT USE THE FIXTURE:
 - IN PLACES SUBJECT TO VIBRATIONS OR BUMPS
 - IN PLACES WITH EXCESSIVE HUMIDITY
 - IN PLACES SUBJECT TO TEMPERATURES OF MORE THAN 45° OR LESS THAN 2°C



- DO NOT PLACE THE UNIT ON INFLAMMABLE PARTS OR MATERIAL
- PROTECT THE FIXTURE FROM EXCESSIVE HUMIDITY (IDEAL VALUES ARE BETWEEN 35 AND L'80%).
- AVOID INFLAMMABLE LIQUIDS, WATER OR METALLIC OBJECTS ENTERING THE FIXTURE .
- DON'T LIFT THE FIXTURE HOLDING IT BY THE MOVING PART (THE HEAD).

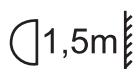

- POSITION THE FIXTURE AT LEAST 1.5M. FROM THE SURFACE TO BE LIT.
- KEEP ANY INFLAMMABLE MATERIAL AT A DISTANCE OF AT LEAST 1.5M FROM THE FIXTURE.

1.92 Positioning the fixture

The unit can be installed in any position.



1.93 Fitting clamps

- Always use two clamps to hang the fixture.
- Fix the fixture to the support structure using safety chains fitted to the 2 holes on the underside of the fixture's base (Fig.2).
- Don't fix the safety chain to the handles.

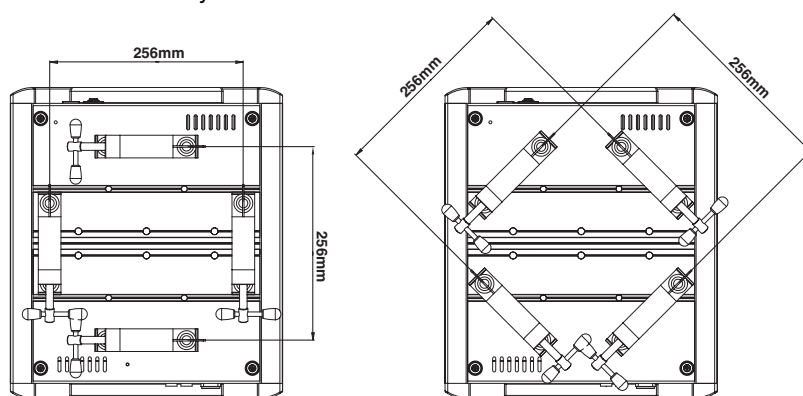

CLAMPS CAN BE USED AS FOLLOWS:

Fig. 1

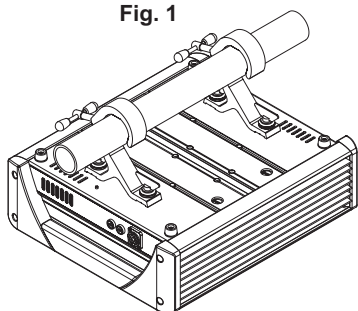

Fig. 2

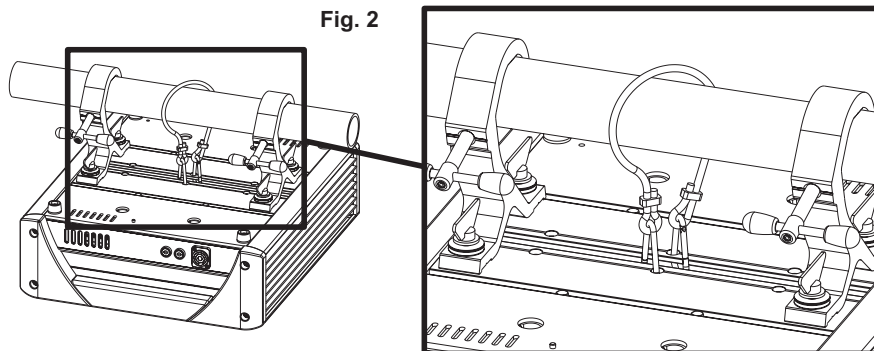

Fig. 3

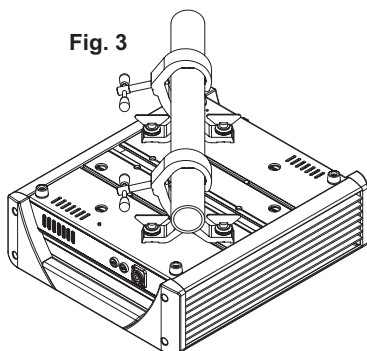
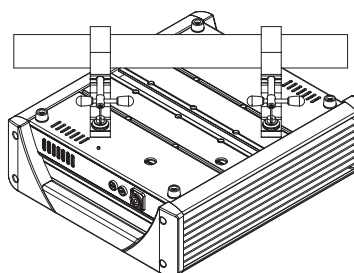

Fig. 4



2.0 - Construction of the signal cable

Giotto spot has a DMX 512 input fitted with standard 5-pin XLR connectors. Screened cables in compliance with EIA RS-485 specifications and the following characteristics must be used for connections:

- 2 conductors plus screen
- 120Ohm impedance
- low capacitance
- max. transmission rate 250kBaud.

Cable connections:

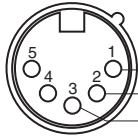

COMMON
DMX-
DMX+

see illustration, taking care with the screen, which must be connected to Pin 1



ATTENTION: the screened parts of the cable (sleeve) must NEVER be connected to the system's earth, as this would cause faulty fixture and controller operation.

Example of connection of the DMX line

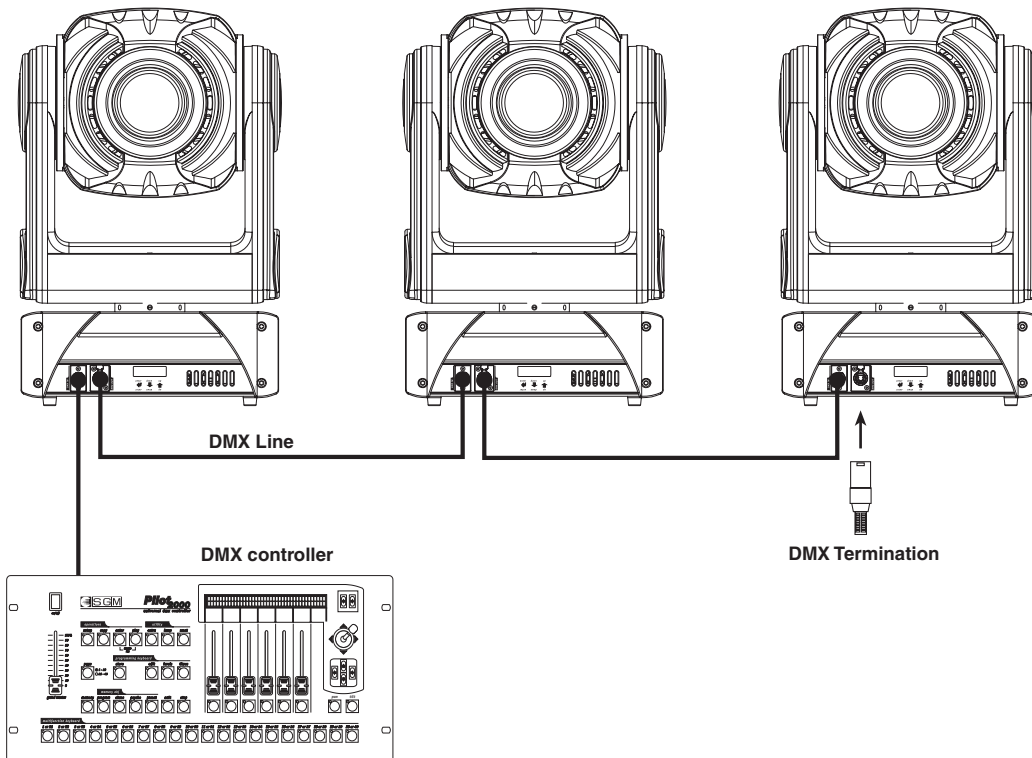

To avoid the risk of faulty operation, follow these indications:

Maximum cable length: 500 metres

Max. N° of fixtures connected: 32

Cable runs: Avoid running cables alongside power supply lines.

Termination: A 120Ohm resistor between Pins 2 and 3 on the last fixture.

2.1- Construction of the DMX termination

The termination avoids the risk of DMX 512 signals being reflected back along the cable when they reaches the end of the line: under certain conditions and with certain cable lengths, this could cause them to cancel the original signals.

The termination is prepared by soldering a 120Ohm 1/4 W resistor between pins 2 and 3 of the 5-pin male XLR connector (see diagram).

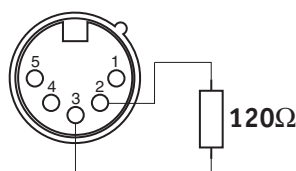

2.2 RS232 connection

For this connection, use good quality screened coax cable (RG58 50Ohms) to avoid problems with signal transmission and faulty fixture operation.

Connectors must always be 5-pin XLRs. Refer to the diagram for wiring.

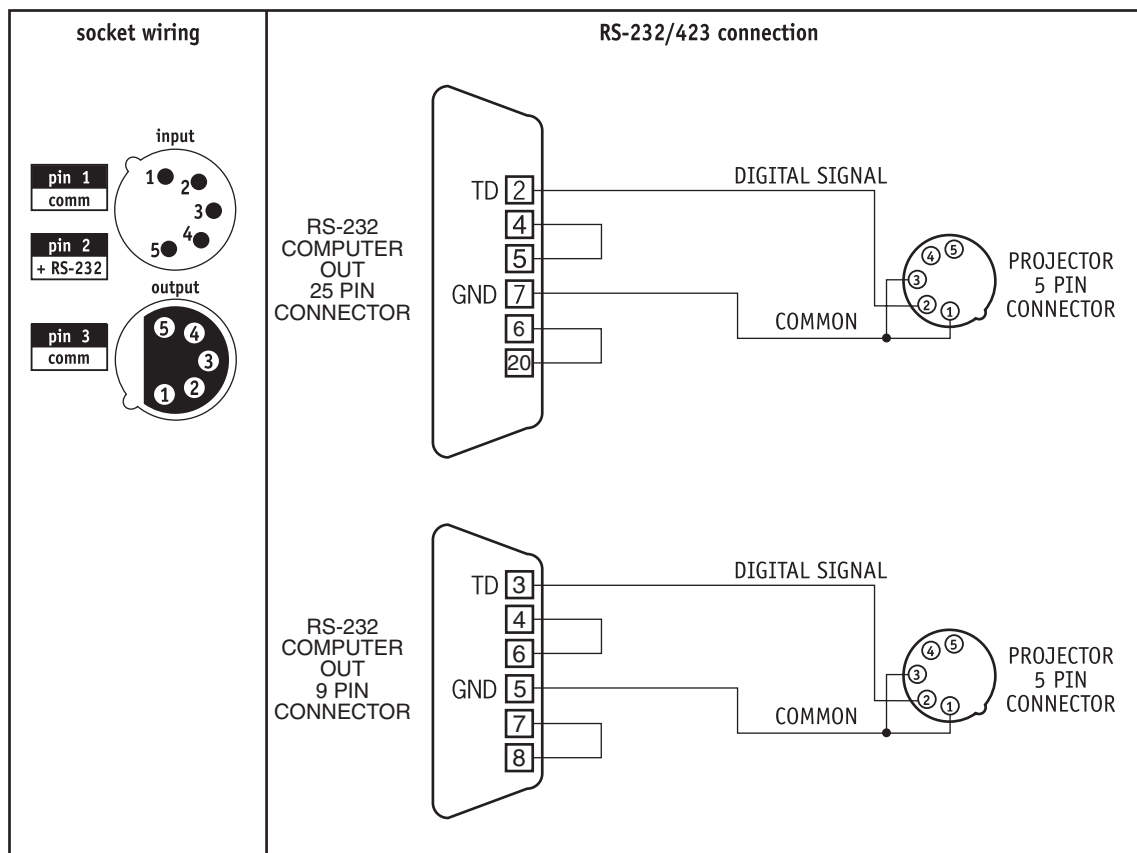

2.3 Upgrading the fixture's firmware

To carry out this procedure, the uploader kit connected to a PC and the file containing the software upgrade are required. Up to eight fixtures can be upgraded simultaneously.

3.0 "Control" Microcomputer

Giotto Spot is equipped with a microcomputer which allows to customize the fixture to suite the type of installation. In fact, it's possible to assign the start address; obtain information regarding lamp life and fixture operation time; run test programs to check correct fixture operation and customize some parameters.

3.1 Navigating in the menu

When it's switched on, the fixture runs a start-up reset procedure and the display indicates if there's an input signal or not.

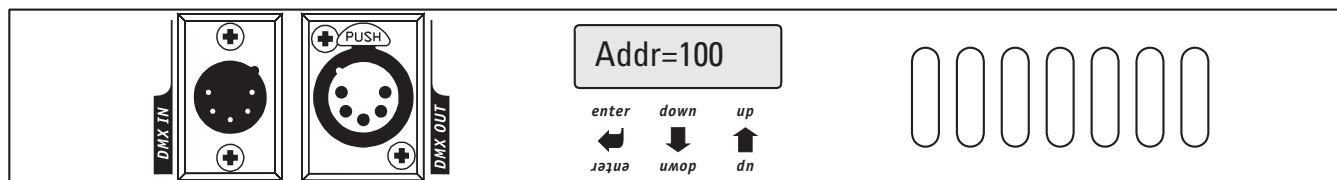

The 3 keys under the display are for selecting and using the various submenus which make up the main menu.

- **UP/DOWN** keys: used to scroll the various items in the menu. In the selected menu, used to change the required parameters.
- **ENTER** key: used to access to the selected menu and, once the necessary changes have been made, is used to confirm them.

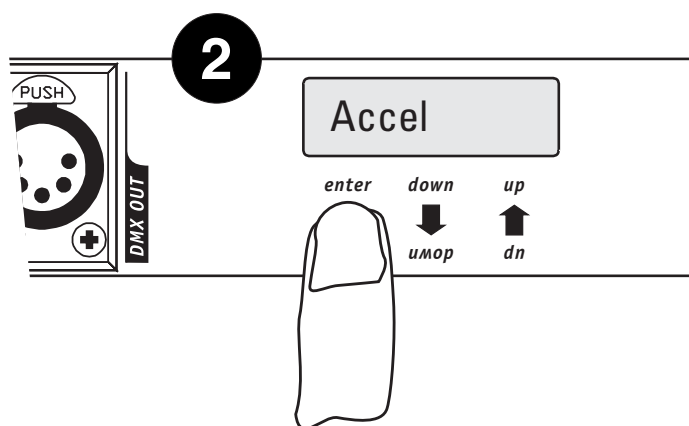
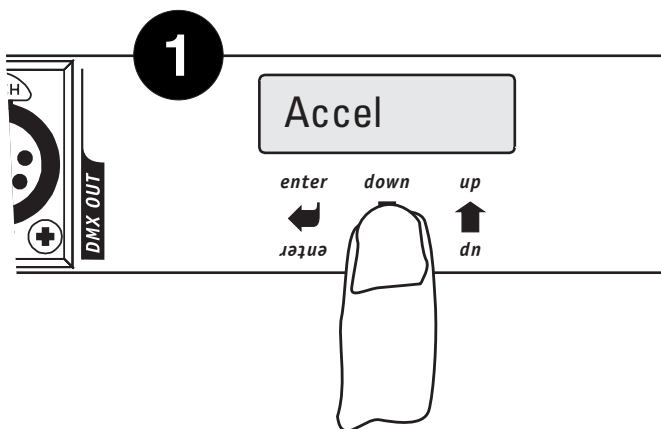



Menu	Options	Description
Addr=xxxx	Range 001-480	Fixture addressing
Pmove	NORM	Normal PAN control of left to right PAN movement.
	REV	Inverted PAN movement control (from right to left).
PP_min	Range 000-536	Sets PAN movement start position. Default configuration = 000 degrees
PP_max	Range 004-540	Sets PAN movement stop position. Default configuration = 000 degrees
Tmove	NORM	Normal control of TILT from up to down.
	REV	Inverted TILT movement control (from down to up).
TP_min	Range 000-236	Sets TILT movement start position. Default configuration = 000 degrees
TP_max	Range 004-270	Sets TILT movement stop position. Default configuration = 000 degrees
Swap	ON	Data regarding Pan controls Tilt and vice versa.
	OFF	Normal control of Pan and Tilt movement.
Lmp_H	-	Read-only Menu. Stores lamp elapsed time. Can be reset.
Lmp_st	-	Read-only Menu. Stores the number of lamp strike. Can be reset.
SCN_h	-	Read-only Menu. Stores fixture operating time.
SIGN	DMX	DMX signal selected
	RS-232	RS-232 signal selected
SMD	16 bit 8 bit	Enables selection of movement resolution. Default configuration = 16 bit
GMD	16 bit 8 bit	Enables selection gobo indexing resolution. Default configuration = 8 bit
LMP_ctr	EN	Remote lamp ignition enabled.
	DS	Remote lamp ignition disabled.
RST_ctr	EN	Remote reset enabled.
	DS	Remote reset disabled.
Speed	100% - 92%	Allows to slow maximum Pan and Tilt speed. Default configuration = 100%
	84% - 76%	
Accel	Fast	Optimises speed performance.
	Slow	Optimises smooth movement
Bright	100-53-40-27 20-13-6-0(%)	Allows adjustment of display brightness. Default configuration =40%
Dsp1Flip	-	Inverts display reading position. Used according to the position in which the fixture is installed.
DMXdly	Range 8-998sec	It's possible to set the number of second for which the fixture's last operating status must be held when there is no DMX signal. (default =UNL)
	UNL	Always maintains the fixture's last operating status no matter for how long there is no DMX signal.
CSHUTT	CSHUTT=DS	Disables shutter closure in the event of loss of position
	CSHUTT=EN	Enables shutter closure in the event of loss of position
FACT	FACT=SET	Enables to set default parameters
	FACT=OFF	FACT Value during normal operation
PREV	PREV=SET	Enables to restore the values of the parameters set immediately before FACT=SET procedure
	PREV=OFF	PREV value during normal operation
SETTING	COL=1200	Enables to set the offset for calibrating the starting position of the colour wheel
	GOB1=2000	Enables to set the offset for calibrating the starting position of the gobo wheel 1
	GOB2=2000	Enables to set the offset for calibrating the starting position of the gobo wheel 2
	RGOB1=1100	Enables to set the offset for calibrating the starting position of the rotating gobos
	RGOB2=1100	Enables to set the offset for calibrating the starting position of the rotating gobos
TEST	TEST=RESET	Fixture RESET.
	TEST=ALL	
	TEST=PAN	
	TEST=TILT	
	TEST=COLOR	
	TEST=GOB01	
	TEST=GOB02	
	TEST=RGOB1	
	TEST=RGOB2	
	TEST=SHUTT	
	TEST=DI MM	
	TEST=FR0ST	
	TEST=FOCUS	
TEST=ZOOM		

Menu	Options	Description
TEST	TEST=GSHK1	
	TEST=GSHK2	
	TEST=ANWHE	
	TEST=CYANO	
	TEST=MAGEN	
	TEST=YELLW	
	TEST=CTO	
Reserved	-	-
temperatur	INPT 28 °C	
	INPT 82 °F	
	HEAD 28 °C	
	HEAD 82 °F	
	CMY __ °C	
	CMY __ °F	
Version	INPT 1.0	
	HEAD 1.0	
	CMY 1.0	
ADDR=100	-	Under normal operating conditions, the display shows this message (100 is the DMX 512 channel on which the first channel set)

3.2 Allocating the first addressed channel

Addr=xxx

In order to receive the commands necessary to operate from a lighting console, each fixture has to be allocated a start address. This address normally indicates the first channel used (start channel) and can be allocated following a different criterion from that used to connect the signal line. Giotto uses 33 controls channels, so during allocation, this quantity must be kept in mind to avoid possible overlapping of other fixtures' channels, which would cause problems with the perfect control of all the available functions. Should it be necessary, it's possible to allocate the same start channel to several fixtures, in this case the fixtures will all follow the same commands, but can't be controlled separately. To address fixtures correctly, proceed as follows:

1. Connect Giotto Spot to the power supply, wait until it has completed reset operations and "DMX signal" appears on the display.
2. Use the UP/DOWN keys to find the "Addr" menu
3. Press ENTER to confirm. The message on the display starts to flash.
4. Use the UP/DOWN keys to select the channel required.
5. Press ENTER to confirm.

Fixture N.	Start Channel	Fixture N.	Start Channel	Fixture N.	Start Channel	Fixture N.	Start Channel
1	001	8	239	15	477		
2	035	9	273	16	511		
3	069	10	307	17			
4	103	11	341	18			
5	137	12	375	19			
6	171	13	409	20			
7	205	14	443	21			

3.3 Direction of Pan movement

Pmove=NORM

This function allows to decide the direction in which the Giotto's moving head pans, indispensable when several fixtures are installed in order that fixtures installed opposite each other move in the same direction when they receive a command.

To modify Pan movement, proceed as follows:

1. Connect the Giotto Spot to the power supply, wait till it has completed reset operations and "DMX signal" appears on the display.
2. Use the UP/DOWN keys to find the "Pmove" menu
3. Press ENTER to confirm. The message on the display will start to flash.
4. Use the UP/DOWN keys to select which of the two available options is required (see table pag. 17).
5. Press ENTER to confirm.

3.31 Setting Pan starting angle

PPmin=000

The Giotto fixture has a Pan movement range of 540° (a revolution and a half). If the entire excursion doesn't have to be used, two parameters allow to set the starting angle (PP_min) and ending angle (PP_max). The only limit is the minimum difference between starting (MIN) and ending angle (MAX), which is 4°.

PPmax=004

To limit Pan movement, proceed as follows:

1. Connect Giotto Spot to the power supply, wait till it has completed reset operations and "DMX signal" appears on the display.
2. Use the UP/DOWN keys to find the "PP_min" menu if the starting angle has to be modified. If the ending angle has to be modified, find the "PP_max" menu.
3. Press ENTER to confirm. The message on the display will start to flash.
4. Use the UP/DOWN keys to select the new starting (or ending) angle.
5. Press ENTER to confirm.

3.4 Direction of Tilt movement

Tmove=NORM

This function allows to decide the direction in which the Giotto's moving head tilts, indispensable when several fixtures are installed in order that fixtures installed opposite each other move in the same direction when they receive a command.

To modify Tilt movement, proceed as follows

1. Connect Giotto Spot to the power supply, wait till it has completed reset operations and "DMX signal" appears on the display.
2. Use the UP/DOWN keys to find the "Tmove" menu
3. Press ENTER to confirm. The message on the display will start to flash.
4. Use the UP/DOWN keys to select which of the two available options is required (see table pag.17).
5. Press ENTER to confirm.

3.41 Limiting Tilt movement

TPmin=000

The Giotto fixture has a Tilt movement range of 270° (3/4 of a revolution). If the entire excursion doesn't have to be used, two parameters allow to limit the starting angle (TP_min) and ending angle (TP_max). The only limit is the minimum difference between starting (MIN) and ending (MAX), which is 4°.

To limit the Tilt movement, proceed as follows:

TPmax=004

1. Connect Giotto Spot to the power supply, wait till it has completed reset operations and "DMX signal" appears on the display.
2. Use the UP/DOWN keys to find the "TP_min" menu if the starting angle is to be modified. If the ending angle is to be changed, find the "TP_max" menu.
3. Press ENTER to confirm. The message on the display will start to flash.
4. Use the UP/DOWN keys to select the new starting (or ending) angle.
5. Press ENTER to confirm.

3.5 Pan/Tilt inversion

Swap=OFF

This function also allows to optimize the movement of the Giotto's moving head in relation to the operator's position, in order to simplify all positioning procedure.

When SWAP is enabled (ON), this means that the lighting console sends the data regarding Pan to the Tilt controls and vice versa. To invert PAN and TILT movement, proceed as follows:

1. Connect Giotto Spot to the power supply, wait till it has completed reset operations and "DMX signal" appears on the display.
2. Use the UP/DOWN keys to find the "SWAP" menu.
3. Press ENTER to confirm. The message on the display will start to flash.
4. Use the UP/DOWN keys to select which of the two available options is required (see table pag.17)
5. Press ENTER to confirm.

3.6 Lamp elapsed time meter

Lmp_H

The Giotto microcomputer stores various data, including that relative to the number of hours the lamp is lit (elapsed time). This is necessary to know in advance when it's almost time for relamping: lamp life is approximately 750 hours.

To see how many hours a lamp has been used, proceed as follows:

1. Connect Giotto Spot to the power supply, wait till it has completed reset operations and "DMX signal" appears on the display.
2. Use the UP/DOWN keys to find the "Lmp_H" menu. The total number of hours the lamp has been lit will be displayed automatically.

3.61 Resetting the lamp elapsed time meterAd

Lmp_h

Each time a new lamp is fitted, it's possible to reset the meter indicating the elapsed time in order to have the real elapsed time for the lamp about to be fitted. To reset the elapsed time meter, proceed as follows:

1. Connect Giotto Spot to the power supply, wait till it has completed reset operations and "DMX signal" appears on the display.
2. Use the UP/DOWN keys to find the ""Lmp_h" menu.
3. Press ENTER to confirm. The message on the display will start to flash.
4. The DOWN key can be used to reset the meter.
5. On the contrary, pressing the UP key restores the previous value.
6. Press ENTER to confirm the changes.

3.7 Lamp strike meter

Lmp_st

The Giotto's microcomputer stores various data, including those relative to the number of lamp strikes. This information is important because needless lamp strikes causes stress to materials and components, so can contribute to reducing lamp life. To know how many times a lamp has been ignited:

1. Connect Giotto Spot to the power supply, wait till it has completed reset operations and "DMX signal" appears on the display.
2. Use the UP/DOWN keys to find the ""Lmp_st" menu. The number of lamp strikes will be displayed automatically.

3.71 Resetting the lamp strike meter

Lmp_st

Each time the fixture is relamped, it's possible to reset the meter which counts the strikes, in order to have number of actual strikes for the lamp about to be installed.

To reset the meter, proceed as follows:

1. Connect Giotto Spot to the power supply, wait till it has completed reset operations and "DMX signal" appears on the display.
2. Use the UP/DOWN keys to find the ""Lmp_st" menu.
3. Press ENTER to confirm. The message on the display will start to flash.
4. The DOWN key can be used to reset the meter.
5. On the contrary, pressing the UP key restores the previous value.
6. Press ENTER to confirm the modifications.

3.8 Fixture operating time meter

SCN_h

This function allows to see for how many hours the fixture has been operating. This meter cannot be reset.

To see for how many hours the fixture has been used, proceed as follows:

1. Connect Giotto Spot to the power supply, wait till it has completed reset operations and "DMX signal" appears on the display.
2. Use the UP/DOWN keys to find the "Scn_H" menu. The number of fixture operating hours will be displayed automatically.

3.9 Input signal

SIGN=DMX

This function allows to choose the type of input signal to be used: DMX 512 or RS-232.

To select the required signal, proceed as follows:

1. Connect Giotto Spot to the power supply, wait till it has completed reset operations and "DMX signal" appears on the display.
2. Use the UP/DOWN keys to find the "Sign=DMX" menu.
3. Press ENTER to confirm. The message on the display will start to flash.
4. Use the UP/DOWN keys to select the type of signal to be used.
5. Press ENTER to confirm the changes.

3.10 Pan/Tilt movement resolution

SMD=16 Bit

This function allows to define the movement resolution (16 or 8 bit). The difference is in the number of steps in which the range of head movement is divided. In 16-bit mode, 540° of Pan and 240° of Tilt are divided into 65,536 steps, ensuring very smooth precision even at very low speeds. In 8-bit mode, the number of steps is 256, which nevertheless allow precise movements.

1. Connect Giotto Spot to the power supply, wait till it has completed reset operations and "DMX signal" appears on the display.
2. Use the UP/DOWN keys to find the ""SMD" menu.
3. Press ENTER to confirm. The message on the display will start to flash.
4. Use the UP/DOWN keys to select the type of resolution required.
5. Press ENTER to confirm the modifications.



3.11 Remote control of lamp ignition

Lmp_ctr=DS

Operators can decide if the ignition of the Giotto's lamp is to be controlled from a lighting console or be automatic. To access this function, proceed as follows:

1. Connect Giotto Spot to the power supply, wait till it has completed reset operations and "DMX signal" appears on the display.
2. Use the UP/DOWN keys to find the "LMP_ctr" menu.
3. Press ENTER to confirm. The message on the display will start to flash.
4. Use the UP/DOWN keys to select the required option.
5. Press ENTER to confirm the modifications.

3.12 Remote control of fixture reset

RST_st=DS

Using this menu, it's possible to decide whether to reset the fixture via remote control or not. To enable this function, proceed as follows:

1. Connect Giotto Spot to the power supply, wait till it has completed reset operations and "DMX signal" appears on the display.
2. Use the UP/DOWN keys to find the "RST_ctr" menu.
3. Press ENTER to confirm. The message on the display will start to flash.
4. Use the UP/DOWN keys to select the required option.
5. Press ENTER to confirm the changes.

3.13 Control of the acceleration of movement speed

Speed=100%

Movement can be optimized by changing the speed (SPEED) and acceleration (ACCEL) parameters, obtaining smooth fast or slow movements as required.

To optimize movement, proceed as follows:

1. Connect Giotto Spot to the power supply, wait till it has completed reset operations and "DMX signal" appears on the display.
2. Use the UP/DOWN keys to find the "Speed" or "Accel" menu.
3. Press ENTER to confirm. The message on the display will start to flash.
4. Use the UP/DOWN keys to select the required option.
5. Press ENTER to confirm the changes.

Accel=Fast

3.14 Display brightness

Bright=40%

Operators can select one of the brightness levels available for the Giotto display, which can be standard or very low. This option is intended for theatre and television use, where excessive brightness can be troublesome.

To change display brightness, proceed as follows:

1. Connect Giotto Spot to the power supply, wait till it has completed reset operations and "DMX signal" appears on the display.
2. Use the UP/DOWN keys to find the "Bright" menu.
3. Press ENTER to confirm. The message on the display will start to flash.
4. Use the UP/DOWN keys to select the required option from those available.
5. Press ENTER to confirm the modifications.

3.15 Display reading position

DsplFlip

When the fixture is mounted "upside down" on a structure, operators can turn the display through 180°, thus greatly facilitating the reading of the menus on the display.

To change the reading position, proceed as follows:

1. Connect Giotto Spot to the power supply, wait till it has completed reset operations and "DMX signal" appears on the display.
2. Use the UP/DOWN keys to find the "Dspl Flip" menu.
3. Press ENTER to confirm. The message on the display will start to flash.
4. Use the UP/DOWN keys to select the required option.
5. Press ENTER to confirm the modifications.

3.16 dmx dly

DMXdly=20

This allows to set the for how many seconds the fixture's last operating settings are maintained should there be no DMX signal. This function is indispensable in those cases in which there is an accidental DMX failure.

To set the required time, proceed as follows:

1. Connect Giotto Spot to the power supply, wait till it has completed reset operations and "DMX signal" appears on the display.
2. Use the UP/DOWN to find the "DMXDLY" menu.
3. Press ENTER to confirm. The message on the display will start to flash.
4. Use the UP/DOWN keys to select the required time.
5. Press ENTER to confirm changes.

3.17 Locking/unlocking the shutter

This feature allows to disable or enable Shutter closure if PAN or TILT lose their position.

CSHUTT=EN

CSHUTT=DN

1. Connect Giotto Spot to the power supply, wait until it has finished reset procedure and "DMX signal" appears on the display.
2. Use the UP/DOWN keys to go to the "CSHUTT" menu
3. Press "Enter" and hold it down for a few seconds to confirm. The message on the display starts flashing.
4. Use the UP/DOWN keys to select "CSHUTT=EN " or "CSHUTT=DN " to enable or disable the closure of the shutter if the fixture is accidentally moved.
5. Press "Enter" to save the value set

3.18 Setting default parameters

This feature allow to set the default parameters:

FACT=Set

FACT=Off

1. Connect Giotto Spot to the power supply, wait until it has finished reset procedure and "DMX signal" appears on the display.
2. Use the UP/DOWN keys to go to the "FACT" menu.
3. Press "Enter" to confirm. The message on the display starts flashing.
4. Use the UP/DOWN keys to select "FACT=SET" and press "Enter".
5. By pressing "Enter" in this mode, the default parameters shown in the table are set and "FACT=OFF" appears on the display.

Menu Item	Default Parameter
ADDR	001
Pmove	NORM
PP_min	000 gradi
PP_max	540 gradi
Tmove	NORM
TP_min	000 gradi
TP_max	240 gradi
SWAP	OFF
SIGN	DMX
SMD	16 BIT
GMD	8 BIT
LMP_ctr	DS
RST_ctr	EN
SPEED	100%
ACCEL	FAST
Bright	40%
DMXdly	UNL
CSHUTT	DS

3.19 Restoring default parameters

This feature allows to reset the values of the parameters which were set immediately before FACT=SET procedure. In other words, if the default parameters have been set by mistake, this allows to return to the values previously set.

PREV=Set

PREV=OFF

1. Connect Giotto Spot to the power supply, wait until it has finished reset procedure and "DMX signal" appears on the display.
2. Use the UP/DOWN keys to go to the "Prev" menu
3. Press "Enter" and hold it down for a few seconds to confirm. The message on the display starts flashing.
4. Use the UP/DOWN keys to select "PREV=SET"
5. Press "Enter" - this restores the values, cancelling the FACTORY DEFAULT operation. In the meantime, PREV stops flashing and PREV=OFF appears.

3.20 Setting the starting position of the rotating gobos and the gobo, colour and effects wheels

SETTING

From the Setting menu, it's possible to set the starting position of the colour, gobo and effects wheels, as well as the starting position of the rotating gobos. To carry out the setting, proceed as follows:

COL=0

GOB1=0

GOB2=0

RGOB1=0

RGOB2=0

1. Connect Giotto Spot to the power supply, wait until it has finished reset procedure.
2. Use the UP/DOWN keys to go to the "SETTING" menu
3. Press "Enter" .
4. Use the UP/DOWN keys to select "COL, GOB1, GOB2, RGOB1, RGOB2
5. Press "Enter" to select - the writing on the display will begin to flash.
6. Set the offset with the UP/DOWN keys
7. Press ENTER to confirm (the writing stops flashing) and return to the SETTING submenu
8. Once all the settings have been done, press ENTER for 4 seconds to exit the Setting menu.

3.21 Test functions

TEST

Test programs can be used in the event of it being necessary to check the correct operation of the fixture or some of its parts.

To selection the required test program, proceed as follows:

TEST=Reset

1. Connect Giotto Spot to the power supply, wait till it has completed reset operations and "DMX signal" appears on the display.
2. Use the UP/DOWN keys to find the "Test" menu.
3. Press ENTER and hold it down for a few seconds to confirm. The message on the display will start to flash.
4. Use the UP/DOWN keys to select the program corresponding to the part of the fixture to be tested.
5. Press ENTER to run the test program.
6. To quit the test functions, press ENTER once, then press it again for a few seconds until "Test" re-appears on the display.

3.22 Reserved functions

Reserved

Some fixture functions can't be accessed by operators as they regard software sections as yet to be defined in this firmware release. When RESERVED appears on the display, you're in this section. Access is forbidden.



Control channels

DMX Channel	FUNCTION	DESCRIPTION
ch1	Pan MSB	Pan 8bit
ch2	Pan LSB	Pan 16 bit
ch3	Tilt MSB	Tilt 8 bit
ch4	Tilt LSB	Tilt 16 bit
ch5	Iris	Iris aperture control
ch6	Colore	6 colors + rainbow + music change
ch7	Gobo1	8 Gobos + rainbow + music change
ch8	Shutter/ Strobe	Shutter and strobe with music sync Black out gobo and colour change
ch9	Dimmer	Mechanical dimmer
ch10	Gobo1 rotation (MSB)	Gobo1 indexing and rotation 8 bit
ch11	Prism / Flattener	
ch12	Prism rotation	Regulation of prism rotation speed in one direction or the other
ch13	Motorized Focus	Enables images to be focussed
ch14	Zoom	Widening / narrowing of light beam (0 - 22°)
ch15	Animation Wheel	Animation Wheel
ch16	Frost	Variable frost
ch17	Mspeed	Movement speed
ch18	Reset/Lamp	
ch19	Gobo1 shake	Gobo1 shaking
ch20	Mod_col	Indexable position, hard full color change,hard half color change, rainbow 8 speed, music color change
ch21	Mod_rotg1	Gobo1 position indexing, gobo rotation , gobo shaking
ch22	Macro	Macro function
ch23	Rotation Gobo1(LSB)	GoboWheel1 indexing and rotation 16 bit
ch24	Gobo2	8 Gobos + rainbow + music change
ch25	Gobo2 rotation (MSB)	Gobo2 indexing and rotation 8 bit
ch26	Gobo2 rotation (LSB)	Gobo2 indexing and rotation 16 bit
ch27	Mod_rotg2	Gobo2 position indexing, gobo rotation , gobo shaking
ch28	Gobo2shake	Gobo2 shaking
ch29	Animation Wheel Rotation	Animation wheel rotation
ch30	Cyan	Linear Cyan insertion
ch31	Magenta	Linear Magenta insertion
ch32	Yellow	Linear Yellow insertion
ch33	CTO	Linear Cto insertion

Iris (Ch5)

DMX VALUE	FUNCTION
0 - 255	LINEAR OPENING REGULATION 0 – 100%

Color mode (Ch20)

DMX VALUE	CENTRAL VALUE	FUNCTION	
0 – 50	25	FULL COLOR	Digital color regulation on central position
51 – 101	75	HALF COLOR	Digital color regulation on intermediate position
102 – 152	125	COLOR SOFT	Analog color selection on any position
153 – 203	175	RAINBOW SOFT	Color rotation at different speed Digital
204 – 255	225	MUSIC HARD CHANGE	color music change sincronized with low frequency

Color (Ch6) with Color mode (Ch20) = Full Color

DMX VALUE	CENTRAL VALUE	FUNCTION
0 – 35	17	WHITE
36 – 71	53	RED
72 – 107	89	GREEN
108 – 145	125	BLUE
146 – 181	161	PINK
182 – 215	197	AMBER
216 – 255	233	WOOD

Color (Ch6) with Color mode (Ch20) = Half Color

DMX VALUE	CENTRAL VALUE	FUNCTION
0 - 31	15	WHITE
32 – 63	47	WHITE / RED
64 – 95	79	RED / GREEN
96 – 127	111	GREEN / BLUE
128 – 159	143	BLUE / PINK
160 – 191	175	PINK / AMBER
192 – 223	207	AMBER / WOOD
224 – 255	239	WOOD / WHITE

Color (Ch6) with Color mode (Ch20)= Color Soft

DMX VALUE		FUNCTION
Colore indicizzato LINEAR REGULATI ON del colore in ogni campo	C = 0	WHITE
	C = 36	RED
	C = 72	GREEN
	C = 108	BLUE
	C = 144	PINK
	C = 180	AMBER
C = 216	WOOD	

Color (Ch6) with Color mode (Ch20)= Rainbow Soft

DMX VALUE	CENTRAL VALUE	FUNCTION
0 -15	8	SPEED 1
16 – 31	24	SPEED 2
32 – 47	40	SPEED 3
48 – 63	56	SPEED 4
64 – 79	72	SPEED 5
80 – 95	88	SPEED 6
96 – 111	104	SPEED 7
112 – 127	120	SPEED 8
128 – 143	136	SPEED 9
144 – 159	152	SPEED 10
160 – 175	168	SPEED 11
176 – 191	184	SPEED 12
192 – 207	200	SPEED 13
208 – 223	216	SPEED 14
224 – 239	232	SPEED 15
240 – 255	248	SPEED 16

Color (Ch6) with Color mode (Ch20)= Music hard change

DMX VALUE	FUNCTION
0 – 127	MUSIC HARD CHANGE FULL COLOR
128 – 255	MUSIC HARD CHANGE ALF COLOR

Gobos wheel 1 (Ch7)

DMX VALUE	CENTRAL VALUE	FUNCTION
0 – 20	10	WHITE
21 – 41	31	WHEEL1-GOBO 1
42 – 62	52	WHEEL1-GOBO 2
63 – 83	73	WHEEL1-GOBO 3
84 – 104	94	WHEEL1-GOBO 4
105 – 125	115	WHEEL1-GOBO 5
126 – 146	136	WHEEL1-GOBO 6
147 – 167	157	WHEEL1-GOBO 7
168 – 189	178	WHEEL1-GOBO8
190 – 196	193	RAINBOW SPEED1
197 – 203	200	RAINBOW SPEED2
204 – 210	207	RAINBOW SPEED3
211 – 217	214	RAINBOW SPEED4
218 – 224	221	RAINBOW SPEED5
225 – 231	228	RAINBOW SPEED6
232 – 238	235	RAINBOW SPEED7
239 – 245	242	RAINBOW SPEED8
246 – 255	252	GOBOS MUSIC CHANGE

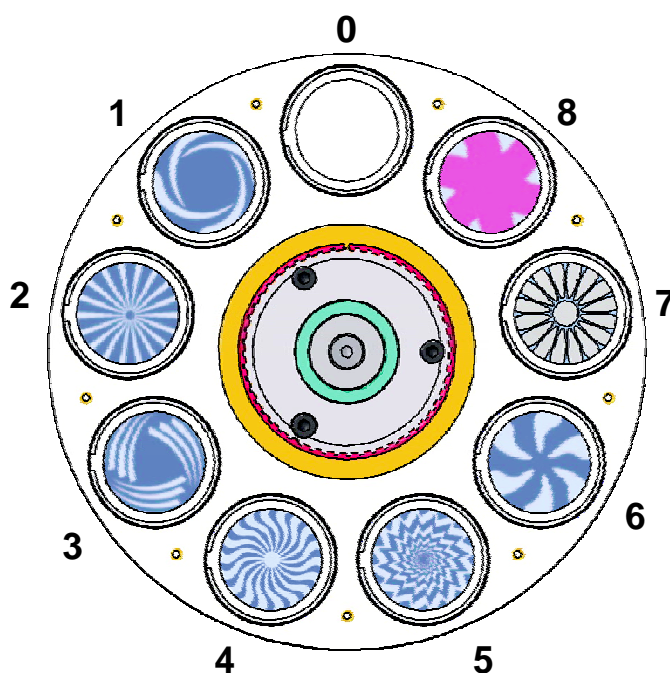
**Shutter/ strobo (Ch8)**

DMX VALUE	CENTRAL VALUE	FUNCTION
0 -- 7	4	CLOSED
8 --15	12	STROBE FREQUENCY OF 1HZ
16 -- 23	20	STROBE FREQUENCY OF 1,38 HZ
24 – 31	28	STROBE FREQUENCY OF 1,6 HZ
32 – 39	36	STROBE FREQUENCY OF 1,9 HZ
40 -- 47	44	STROBE FREQUENCY OF 2,3 HZ
48 -- 55	52	STROBE FREQUENCY OF 2,7 HZ
56 -- 63	60	STROBE FREQUENCY OF 3,4 HZ
64 -- 71	68	STROBE FREQUENCY OF 4 HZ
72 --79	76	STROBE FREQUENCY OF 5 HZ
80 --87	84	STROBE FREQUENCY OF 6 HZ
88 -- 95	92	STROBE FREQUENCY OF 7 HZ
96 -- 103	100	STROBE FREQUENCY OF 8 HZ
104 -- 111	108	STROBE FREQUENCY OF 9 HZ
112 -- 119	116	STROBE FREQUENCY OF 10 HZ
120 -- 136	128	SHUTTER STROBE LOW. STROBE EFFECT AT 10 HZ SINCRONIZED ON LOW AUDIO FREQUECYES
137 -- 153	145	MUSIC FLASH LOW
154 – 170	162	OPEN AUTOSHADE ON GOBOS
171 -- 187	179	OPEN AUTOSHADE ON COLORS
188 -- 204	196	OPEN AUTOSHADE ON GOBOS AND COLORI
205 -- 221	213	OPEN WITH SLOW GOBO CHANGE
222 -- 255		OPEN

Dimmer (Ch9)

DMX VALUE	FUNCTION
0 – 255	LINEAR REGULATION 0 – 100%

Gobos wheel 2 (Ch24)

DMX VALUE	CENTRAL VALUE	FUNCTION
0 – 20	10	WHITE
21 – 41	31	WHEEL 2-GOBO 1
42 – 62	52	WHEEL 2-GOBO 2
63 – 83	73	WHEEL 2-GOBO 3
84 – 104	94	WHEEL 2-GOBO 4
105 – 125	115	WHEEL 2-GOBO 5
126 – 146	136	WHEEL 2-GOBO 6
147 – 167	157	WHEEL 2-GOBO 7
168 – 189	178	WHEEL 2-GOBO 8
190 – 196	193	RAINBOW SPEED1
197 – 203	200	RAINBOW SPEED2
204 – 210	207	RAINBOW SPEED3
211 – 217	214	RAINBOW SPEED4
218 – 224	221	RAINBOW SPEED5
225 – 231	228	RAINBOW SPEED6
232 – 238	235	RAINBOW SPEED7
239 – 245	242	RAINBOW SPEED8
246 – 255	252	GOBOS MUSIC CHANGE

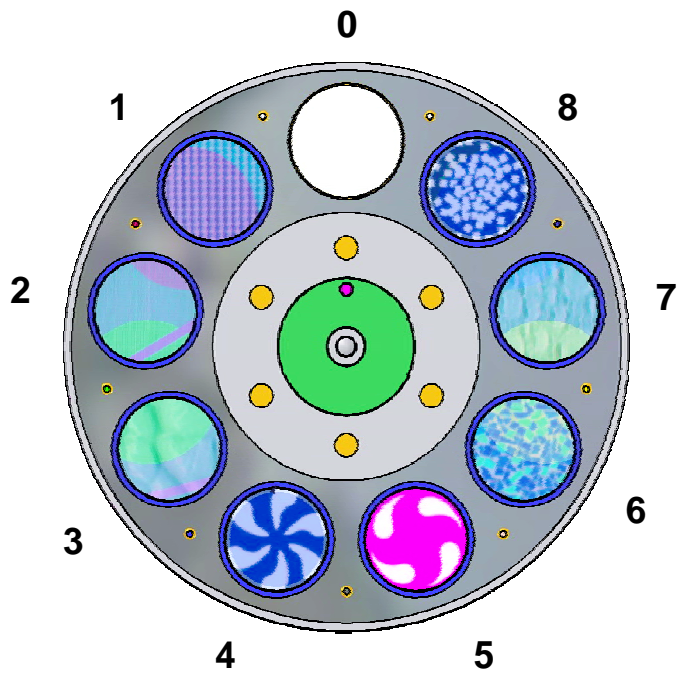

Gobo1 rotation mode (Ch21)

DMX VALUE	FUNCTION
0..127	GOBO1 INDEXABLE POSITION
128 .. 255	GOBO1 ROTATION AT DIFFERENT SPEED IN BOTH DIRECTIONS

gobo 1 (ch10) with gobo1 rotation mode (ch21)=gobo1 indexable position.

DMX VALUE	FUNCTION
0 .. 255	LINEAR GOBOWHEEL1 POSITION REGULATION FOR 360 (MSB)

gobo 1 rotation (ch23) with gobo1 rotation mode (ch21)=gobo1 indexable position.

DMX VALUE	FUNCTION
0..255	LINEAR GOBOWHEEL1 POSITION REGULATION FOR 360 (LSB)

gobo1 rotation (ch10) with gobo1 rotation mode (ch21)=gobo1 rotation at different speed in both directions.

DMX VALUE	FUNCTION
0..111	DOWN ROTATION [MAX . . .MIN]
112 – 144	FIXED
145..255	UP ROTATION [MIN ... MAX]

Gobo2 rotation mode (Ch27)

DMX VALUE	FUNCTION
0..127	GOBO2 INDEXABLE POSITION
128 .. 255	GOBO2 ROTATION AT DIFFERENT SPEED IN BOTH DIRECTIONS

gobo2 rotation msb (ch25) with gobo2 rotation mode(ch27)=gobo2 indexable position

DMX VALUE	FUNCTION
0 .. 255	LINEAR GOBOWHEEL2 POSITION REGULATION FOR 360 (MSB)

gobo2 rotation lsb (ch26) with gobo2 rotation mode(ch27)=gobo2 indexable position

DMX VALUE	FUNCTION
0 .. 255	LINEAR GOBOWHEEL1 POSITION REGULATION FOR 360 (LSB)

gobo2 rotation (ch25) with gobo2 rotation mode (ch27)=gobo2 rotation at different speed in both directions

DMX VALUE	FUNCTION
0 .. 111	DOWN ROTATION [MAX .. MIN]
112 - 144	FIXED
145 .. 255	UP ROTATION [MIN ... MAX]

Zoom (Ch14)

DMX VALUE	FUNCTION
0	ZOOM IN (ANGOLO 12°)
0 – 255	LINEAR VARIATION
255	ZOOM OUT (ANGOLO 22°)

Prism / Flattener (Ch11)

DMX VALUE	FUNCTION
0 – 63	NO PRISM - NO FLATTENER
64 - 127	FLATTENER INSERTED
128 - 191	PRISM INSERTED
192 – 255	PRISM INSERTED - FLATTENER INSERTED

Prism rotation (Ch12)

DMX VALUE	FUNCTION
0 .. 111	DOWN ROTATION [MAX .. MIN]
112 – 143	FERMO
144 .. 255	UP ROTATION [MIN .. MAX]

Animation wheel (Ch15)

DMX VALUE	FUNCTION
0 – 127	NOT INSERTED.
128 – 255	INSERTED.

Animation wheel rotation (Ch29)

DMX VALUE	FUNCTION
0 .. 111	ROTATION DOWN [MAX .. MIN]
112 – 143	ANIMATION WHEEL FERMA
144 .. 255	ROTATION UP [MAX .. MIN]

Motorized focus (Ch13)

DMX VALUE	FUNCTION
0 – 255	LINEAR REGULATION 0 – 100%

Frost (Ch16)

DMX VALUE	FUNCTION
0	FROST DISABLED
0 – 255	LINEAR VARIATION
255	FROST FULLY INSERTED

Gobo1 shake (Ch19)

DMX VALUE	CENTRAL VALUE	FUNCTION
0 – 47		GOBOSHAKE DISABLED
48 – 60	54	GOBOSHAKE SPEED 1
61 – 73	67	GOBOSHAKE SPEED 2
74 – 86	80	GOBOSHAKE SPEED 3
87 – 99	93	GOBOSHAKE SPEED 4
100 – 112	106	GOBOSHAKE SPEED 5
113 – 125	119	GOBOSHAKE SPEED 6
126 – 138	132	GOBOSHAKE SPEED 7
139 – 151	145	GOBOSHAKE SPEED 8
152 – 164	158	GOBOSHAKE SPEED 9
165 – 177	171	GOBOSHAKE SPEED 10
178 – 190	184	GOBOSHAKE SPEED 11
191 – 203	197	GOBOSHAKE SPEED 12
204 – 216	210	GOBOSHAKE SPEED 13
217 – 229	223	GOBOSHAKE SPEED 14
230 – 242	236	GOBOSHAKE SPEED 15
243 – 255	249	GOBOSHAKE SPEED 16

Gobo2 shake (Ch28)

DMX VALUE	CENTRAL VALUE	FUNCTION
0 – 47		GOBOSHAKE DISABLED
48 – 60	54	GOBOSHAKE SPEED 1
61 – 73	67	GOBOSHAKE SPEED 2
74 – 86	80	GOBOSHAKE SPEED 3
87 – 99	93	GOBOSHAKE SPEED 4
100 – 112	106	GOBOSHAKE SPEED 5
113 – 125	119	GOBOSHAKE SPEED 6
126 – 138	132	GOBOSHAKE SPEED 7
139 – 151	145	GOBOSHAKE SPEED 8
152 – 164	158	GOBOSHAKE SPEED 9
165 – 177	171	GOBOSHAKE SPEED 10
178 – 190	184	GOBOSHAKE SPEED 11
191 – 203	197	GOBOSHAKE SPEED 12
204 – 216	210	GOBOSHAKE SPEED 13
217 – 229	223	GOBOSHAKE SPEED 14
230 – 242	236	GOBOSHAKE SPEED 15
243 – 255	249	GOBOSHAKE SPEED 16

Cyano (Ch30)

DMX VALUE	FUNCTION
0	OPEN
0 - 255	LINEAR VARIATION [0...100%]
255	CYANO FULLY INSERTED

Magenta (CH31)

DMX VALUE	FUNCTION
0	OPEN
0 - 255	LINEAR VARIATION [0...100%]
255	MAGENTA FULLY INSERTED

Yellow (CH32)

DMX VALUE	FUNCTION
0	OPEN
0 - 255	LINEAR VARIATION [0...100%]
255	YELLOW FULLY INSERTED

Cto (CH33)

DMX VALUE	FUNCTION
0	OPEN
0 - 255	LINEAR VARIATION [0...100%]
255	CTO FULLY INSERTED

Mspeed (Ch17)

DMX VALUE	FUNCTION
0 .. 3	CONTROLLER CROSS FADE
4 .. 255	SLOWEST .. FASTEST

Remote lamp striking and reset (Ch18)

DMX VALUE	FUNCTION	
10 – 60	OFF	LAMP
61 – 129	HYSTERESIS	
130 -- 179	ON	
180 – 239	HYSTERESIS	RESET
240 – 255	RESET	

Macro (Ch22)

DMX VALUE	CENTRAL VALUE	DESCRIPTION	CHANNELS USED
0 – 7	4		
8 – 15	12	Slow dimmer opening ramp and fast closing	Dimmer Shutter
16 – 23	20	Slow dimmer closing ramp and fast opening	Dimmer Shutter
24 – 31	28	Odd-numbered fixtures run a slow dimmer opening ramp. Even-numbered fixtures run a slow dimmer closing ramp	Dimmer Shutter
32 – 39	36	Odd-numbered fixtures run a slow dimmer opening ramp and even-numbered fixtures' shutters are closed. Then even-numbered fixtures run a slow dimmer opening ramp and odd-numbered fixtures' shutters are closed.	Dimmer Shutter
40 – 47	44	Odd-numbered fixtures run a slow dimmer closing ramp while even-numbered fixtures' shutters are open. Then even-numbered fixtures run a slow dimmer closing ramp and even-numbered fixtures' shutters are open	Dimmer Shutter
48 – 55	52	Slow iris opening ramp and fast closing	Iris
56 – 63	60	Slow iris closing ramp and fast opening	Iris
64 – 71	68	Fast iris closing and opening	iris
72 – 79	76	Odd-numbered fixtures run a slow iris opening ramp, even-numbered fixtures run a slow iris closing ramp	iris
80 – 87	84	Odd-numbered fixtures run a slow iris opening ramp whereas even-numbered fixtures' irises are closed. Then even-numbered fixtures run a slow iris opening ramp and even-numbered fixtures' irises are closed	Iris
88 – 95	92	Odd-numbered fixtures run a slow iris closing ramp whereas even-numbered fixtures' irises are open. Then even-numbered fixtures run a slow iris closing ramp and odd-numbered fixtures' irises are open	Iris
96 – 103	100	Even-numbered fixtures close their irises, whereas odd-numbered fixtures open them and vice versa	Iris
104 – 111	108	Random strobe	Shutter
112 – 119	116	Slow Frost insertion ramp followed by slow removal ramp	Frost
120 – 127	124	Slow Frost insertion ramp followed by fast removal	Frost
128 – 135	132	Slow Frost insertion ramp on even-numbered fixtures, whereas Frost is disabled on odd-numbered units. Then slow Frost insertion ramp on odd-numbered fixtures and Frost disabled on even-numbered fixtures	Frost
136 – 143	140		
144 – 151	148		
152 – 159	156		
160 – 167	164		
168 – 175	172		
176 – 183	180		
184 – 191	188		
192 – 199	196		
200 – 207	204		
208 – 215	212		
216 – 223	220		
224 – 231	228		
232 – 239	236		
240 – 247	244		
248 – 255	252		

Conversion table

DMX VALUE	MSPEED (in seconds)	DMX VALUE	MSPEED (in seconds)	DMX VALUE	MSPEED (in seconds)	DMX VALUE	MSPEED (in seconds)
0 -- 1	cross fade	65	150	129	72	193	17
2	cross fade	66	149	130	70	194	17
3	cross fade	67	147	131	69	195	16
4	243	68	146	132	68	196	16
5	241	69	145	133	67	197	15
6	240	70	143	134	66	198	15
7	238	71	142	135	65	199	14
8	236	72	141	136	64	200	14
9	234	73	139	137	63	201	13
10	233	74	138	138	62	202	13
11	231	75	137	139	61	203	12
12	229	76	135	140	60	204	12
13	227	77	134	141	59	205	12
14	226	78	133	142	58	206	11
15	224	79	131	143	57	207	11
16	222	80	130	144	56	208	10
17	221	81	129	145	55	209	10
18	219	82	128	146	54	210	10
19	217	83	126	147	53	211	9
20	216	84	125	148	52	212	9
21	214	85	124	149	51	213	9
22	213	86	122	150	50	214	8
23	211	87	121	151	49	215	8
24	209	88	120	152	48	216	8
25	208	89	119	153	47	217	7
26	206	90	117	154	46	218	7
27	205	91	116	155	45	219	7
28	203	92	115	156	45	220	6
29	202	93	114	157	44	221	6
30	200	94	112	158	43	222	6
31	199	95	111	159	42	223	6
32	197	96	110	160	41	224	5
33	195	97	109	161	40	225	5
34	194	98	108	162	39	226	5
35	192	99	106	163	38	227	5
36	191	100	105	164	38	228	4
37	189	101	104	165	37	229	4
38	188	102	103	166	36	230	4
39	187	103	101	167	35	231	4
40	185	104	100	168	34	232	4
41	184	105	99	169	34	233	3
42	182	106	98	170	33	234	3
43	181	107	97	171	32	235	3
44	179	108	95	172	31	236	3
45	178	109	94	173	30	237	3
46	176	110	93	174	30	238	3
47	175	111	92	175	29	239	3
48	173	112	91	176	28	240	2
49	172	113	90	177	28	241	2
50	171	114	88	178	27	242	2
51	169	115	87	179	26	243	2
52	168	116	86	180	25	244	2
53	166	117	85	181	25	245	2
54	165	118	84	182	24	246	2
55	164	119	83	183	23	247	2
56	162	120	82	184	23	248	2
57	161	121	80	185	22	249	2
58	159	122	79	186	22	250	2
59	158	123	78	187	21	251	2
60	157	124	77	188	20	252	2
61	155	125	76	189	20	253	2
62	154	126	75	190	19	254	2
63	153	127	74	191	19	255	2
64	151	128	73	192	18		

M001251



SGM Technology for Lighting spa
Via Pio La Torre, 1 - 61010 Tavullia (PU), Italy
Tel. +39 0721 476477 - Fax +39 0721 476170
e-mail: info@sgm.it - <http://www.sgm.it>