

## Kanguro 1215 A

## TECHNICAL SPECIFICATIONS

<b>Frequency Response</b>	(-10 dB) (±3 dB)	36Hz ÷ 16.5kHz 43Hz ÷ 16kHz
<b>Average Dispersion</b>		
500Hz ÷ 10kHz		100° x 95° (HxV)
>5 kHz		90° x 50° (HxV)
500Hz ÷ 4kHz		105° x 105° (HxV)
<b>Impedance (ohms)</b>		
Sat Nom (min)	8	(5 @ 239Hz)
Sub Nom (min)	8	(5 @ 154Hz)
<b>Max Sensitivity (dB SPL 1W 1m)</b>		
Sat Full-space		99
Half-space		102 (Bass only)
Sub Full-space		97,5
Half-space		100,5
<b>Power - Watts AES (loudspeakers)</b>	<b>Cont.</b>	<b>Peak</b>
Sat	250	1000
Sub	350	1400
<b>Max Output Level (calculated)</b>	<b>Cont.</b>	<b>Peak</b>
Sat Full-space	123	129
Half-space	126	132 (Bass only)
Sub Full-space	123	129
Half-space	126	132 (Bass only)
<b>Loudspeakers and Loading</b>		
Sat LF:	1x12" NdFeB High pass Vented box.	
HF:	1x1" Exit (1.75" diaphragm) OUT 4, Horn loaded.	
Sub	1 x 15" NdFeB High pass Vented box.	
<b>Amplifier Power RMS</b>		
Sat	500 watts @ 4 ohms	
Sub	1000 watts @ 4 ohms	
Sat	300 watts @ 8 ohms	
Sub	500 watts @ 8 ohms	
<b>AC mains requirements</b>	110 - 230 VAC - 50/60 Hz versions	



## PHYSICAL PROPERTIES

<b>Product type</b>	Medium power short-throw active loudspeaker system with VARIABLE ENCLOSURE VOLUME. Design patented in Italy and internationally patent pending.
<b>Enclosure Material and Finish</b>	Trapezoidal enclosure in 15 mm. plywood with internal bracing, rounded corners and integral handles. Scratchproof paint.
<b>Standard accessories</b>	Outline closing system (with "T" key supplied) for the hatch to remove the satellite from the subwoofer. Highly resistant vibration-free perforated steel grille (on both Sub and Sat), 5 handles (4 integrated on the Subwoofer, one on Sat), "Stack Align" system for aligning emission centres (on the Sat) speaker stand housing (on both). Outline STAND 210.
<b>Protection</b>	Soft Clipping Soft Startup Standby Soft mute/demute function Under voltage protection Monitor output
<b>Optional accessories</b>	"Trolley" and "Shower Cap" water-proof cover.
<b>Weight (kg) Sub + Sat</b>	
Net (gross)	52 (60)
<b>Dimensions (cm) - Sub</b>	
Height (with packing)	55 (62)
Width (with packing)	55 (62)
Depth (with packing)	60 (68)

## FEATURES

- Active (self-powered) system made up of a satellite and a subwoofer with the former contained inside the latter to reduce space occupied during transport.
- Design patented in Italy (N° 01303453) and patent pending in the most important countries in the world; "Design Excellence" award received at London's PLASA expo in 2001.
- "Plug and play" use.
- 130dB sound pressure at 1 metre, from 35Hz to 18kHz.
- Just 0.13 mc of space occupied: two complete systems can be easily transported in an average statio wagon.
- Extremely linear frequency response and phase response within just ± 45° from 500Hz to 16kHz.
- "Stack Align" system on the satellite, to increase the throw of the two enclosures when stacked and align their emission centres.
- Cabinet internally reinforced for utmost sturdiness, free from harmful coloration due to resonance.

## APPLICATIONS

- Short throw wide dispersion system ideal for no-nonsense live applications as front-fill and down-fill units, for groups, bands and orchestras.
- Multi-function system, particularly suitable for high quality mobile installations.

## frequency response

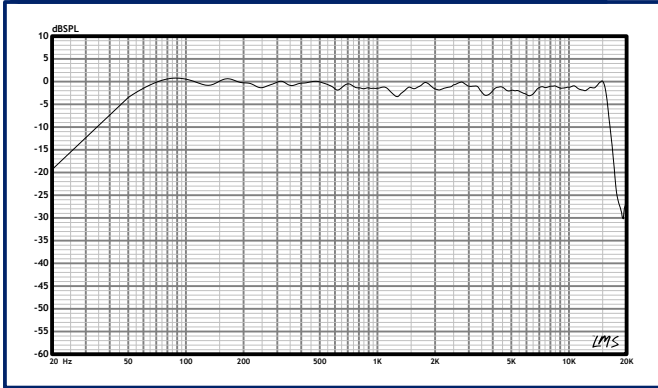

## impedance

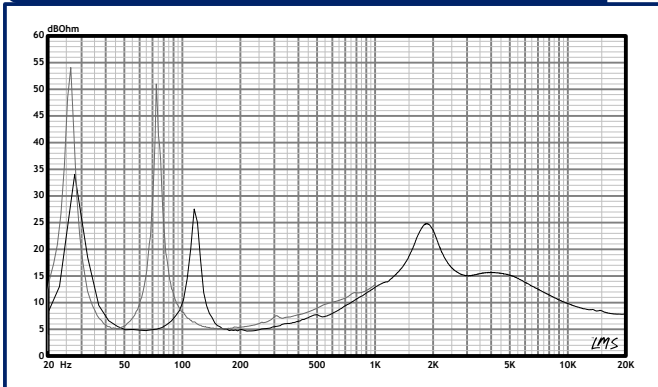

## horizontal polars

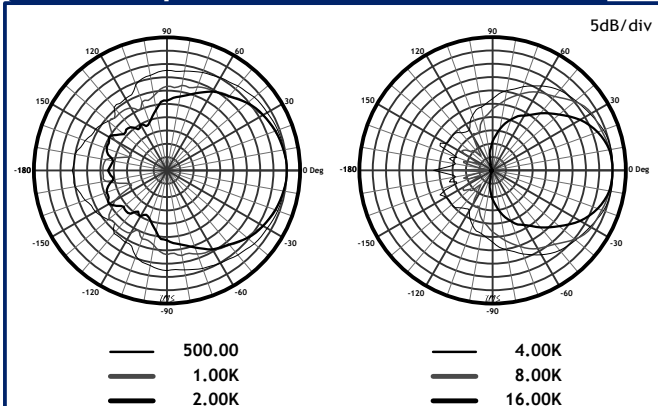

## vertical polars

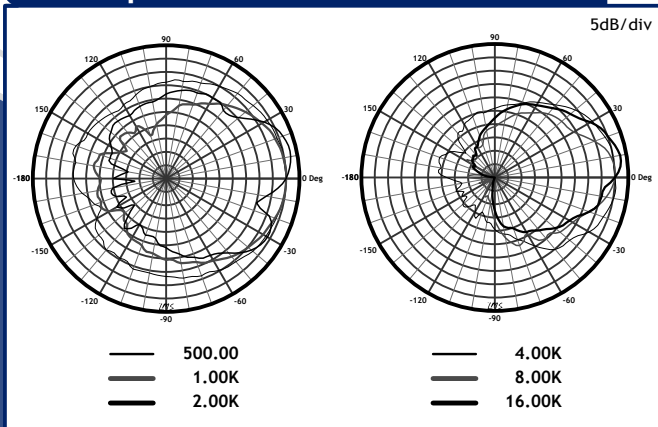

## DESCRIPTION

Compact wide range 3-way bi-amplified loudspeaker system with dedicated built-in amplifiers, comprising a subwoofer which uses a 15" long excursion woofer with a 3" voice coil powered by a 500W RMS amplifier on an impedance of 8 ohms (1000 WRMS 4 ohms) and a "satellite" which uses a 12" woofer, 2.5" voice coil and NdFeB magnet for the mid/low and mid frequencies, and a compression driver with 1.75" duralumin diaphragm and 1" throat for high frequencies, loaded with a controlled directivity wide dispersion horn built in sturdy fiberglass, driven by a 300W RMS amplifier at an impedance of 8 Ohms (500 WRMS 4 ohms). The subwoofer chamber is tuned in such a way as to obtain low resonance and a frequency range reproduced from 36Hz at -10dB and a frequency response within +/-3dB from 43Hz. The satellite also uses the same type of loading (phase inversion with tuned chamber) for the low frequencies. The woofer is positioned further back than the horn in order to align the sound fronts according to the crossover frequency and obtain great phase coherence, from 500Hz to 16kHz in just +/-45°, a feature that is an indication of high quality and improves the performance of individual enclosures, but also of two enclosures side by side or stacked for wider dispersion or longer throw. Directivity is uniform for the majority of the audio range, with average dispersion of 105° H x 105° V in the speech range (500Hz ÷ 4000Hz), and average wide-band sound coverage uniform (100° H x 95° V) from 500Hz to 10kHz. The useable frequency band at -10dB, including the subwoofer, goes from 36Hz to 16.5kHz. The complete system's frequency response measured on axis according to AES standards, is within +/-3dB from 43Hz to 16kHz. With 2-way biamping, hung in full space according to AES standards, the system has a high sensitivity driven with 1W at rated impedance for both the subwoofer section, 97.5dB SPL at 1m, and the mid/low and high frequency section 99dB SPL at 1m, and is able to produce a peak sound pressure of 129dB SPL in the same acoustic conditions, with the sections driven at maximum respective peak power (1400 Watts and 1000 Watts), whereas at minimum impedance (5 Ohms for both) they're able to handle 350 Watts and 250 Watts (continuous) AES. With the system standing on the ground, in 2π conditions, the values of the subwoofer section increase by 3dB SPL with the same driving power, rising to 100.5dB SPL 1W/1m and 132dB SPL peak at full power at 1m. The same happens in the event of using the satellite alone (wide band) standing on the floor or in 2π conditions; the level of the low frequency section increases by 3dB, reaching 102dB SPL 1W 1m and 132dB SPL peak. The subwoofer and satellite enclosures have trapezoidal cabinets in 15mm high quality Baltic birch plywood, reinforced by suitably positioned internal bracing, but the system's most unusual feature consists in the fact that the subwoofer cabinet is built in such a way as to house the satellite inside during transport - the satellite is then removed for use by means of an air-tight hatch. The system's external dimensions, already very small for both enclosures, particularly bearing in mind their high level performance, are almost halved with the precise aim of facilitating travel from place to place, as well as saving vehicle and storage space. The black outer finish is in high quality scratch-resistant paint. The signal connectors for input and for connecting the satellite and subwoofer are panel-mounted XLR male and female models and sufficient are fitted to ensure very flexible use of the system separately or along with others. The subwoofer and satellite cabinets both have a die-cast aluminium socket for fitting the adjustable optional support, while on the top panel of the satellite there's a steel socket containing a plug (supplied) for aligning an enclosure mounted on top (horn to horn) for long-throw configuration ("Stack Align" system). Two practical handles in the rear panels of both enclosures ensure a positive grip during handling. The front protective grilles are in sound transparent painted steel mesh. The front of the subwoofer has sockets to mount an optional trolley for handling the system during transport. This trolley is equipped with long-lasting smooth running wheels for easy movement even on rather rough ground. The market name of the enclosure is KANGURO 1215 A.

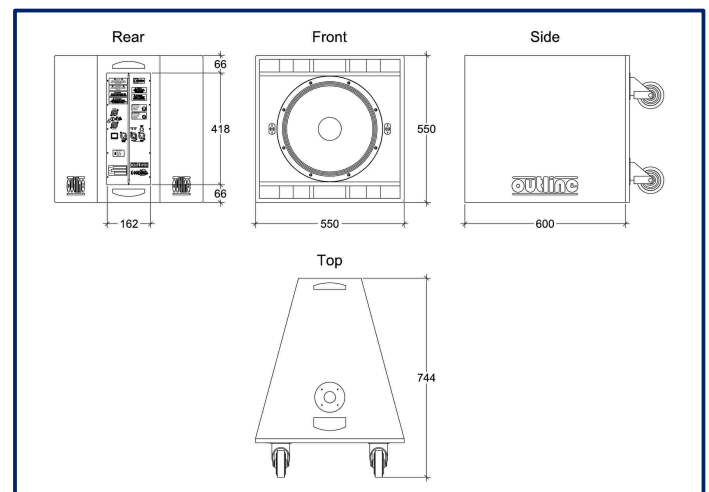

loudspeakers

Kanguro 1215 A

**outline**

Via L. da Vinci, 56 - 25020 Flero (Brescia) Italy  
tel. +39 030 3581351 - fax +39 030 3580431  
www.outline.it - e-mail: info@outline.it