

This document is the absolute property of RBM. This document must not be copied
 without the written permission of RBM.
 The scope, information and data contained herein are disclosed to a third party nor be used for any unauthorized
 purpose. Concomitantly will be prosecuted.

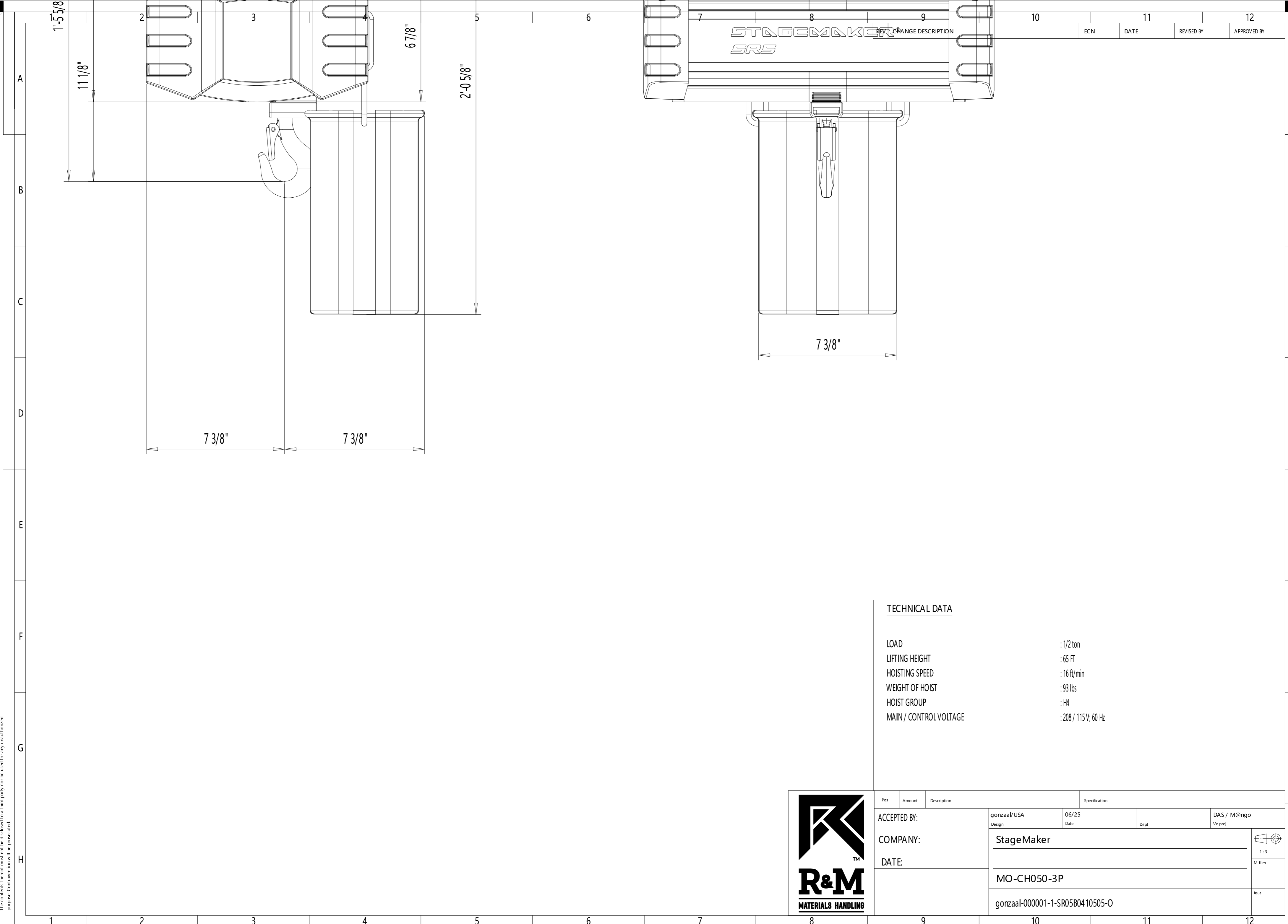

Pos		Amount	Description	Specification
ACCEPTED BY:		gonzaal/USA	06/25	DAS / M@ngo
COMPANY:		Design	Date	Dept Vx proj
DATE:		StageMaker		Issue
		MO-CH050-3P		
		gonzaal-000001-1-SR05B04 10505-O		

TECHNICAL DATA

LOAD : 1/2 ton
 LIFTING HEIGHT : 65 FT
 HOISTING SPEED : 16 ft/min
 WEIGHT OF HOIST : 93 lbs
 HOIST GROUP : H4
 MAIN / CONTROL VOLTAGE : 208 / 115 V; 60 Hz

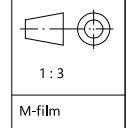

REV	CHANGE DESCRIPTION	ECN	DATE	REVISED BY	APPROVED BY
-----	--------------------	-----	------	------------	-------------

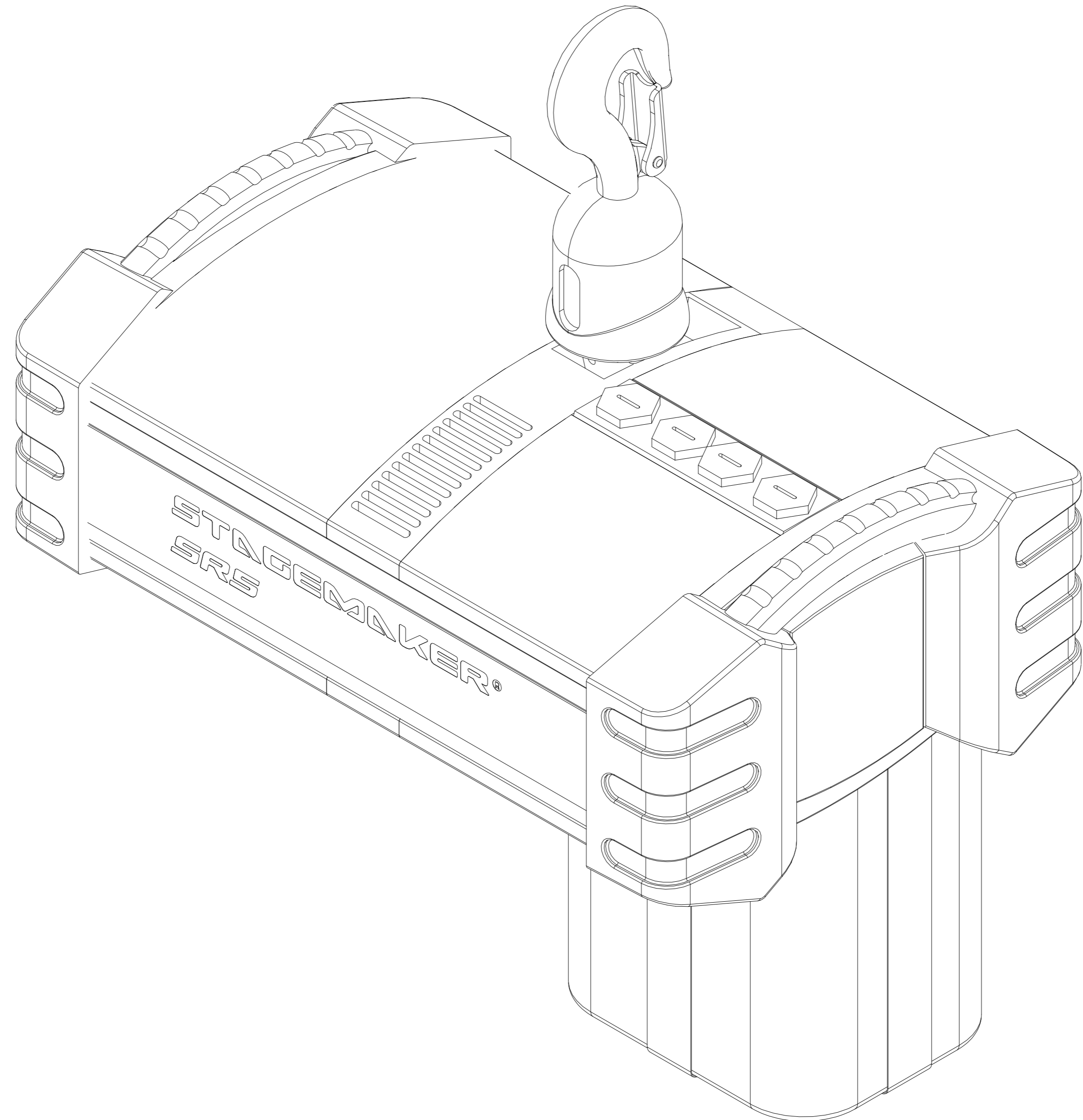

STAGEMAKER[®]
SR5

This document is the absolute property of R&M. This document must not be copied
 without the written permission of R&M.
 The contents thereof must not be disclosed to a third party nor be used for any unauthorized
 purpose. Concomitant will be prosecuted.



Pos	Amount	Description	Specification
ACCEPTED BY:	gonzaal/USA	06/25	DAS / M@ngo
COMPANY:	Design	Date	Dept Vx proj
DATE:	StageMaker		
	MO-CH050-3P		
	gonzaal-000001-1-SR05B0410505-O		

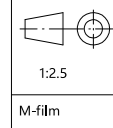

1:2.5

M-Item

Issue