

LAMPO LIGHTING DESIGNERS

**LED TECHNOLOGY**  
AND ARCHITECTURAL LIGHTING



PRODUCT CATALOGUE 2009





**IN-DOOR SOLUTIONS** PAGE 1 / **OUT-DOOR SOLUTIONS IP66/IP65** PAGE 12 / **IN-GROUND SOLUTIONS IP67** PAGE 21 / **UNDERWATER**

# MADE IN ITALY

LAMPO has always stood for his consolidated know-how and a spirit of innovation that, in over 25 years of activity, have made a point of reference both in the domestic and international markets. The production is strictly made in Italy, the excellent production flexibility, allows LAMPO to respond individually to any request, and the search for solutions both in terms of design and functionality, have contributed to the success of LAMPO in the areas of lighting in the professional theatre, television, architecture and photography.





## IN-DOOR SOLUTIONS

**SOLUTIONS IP68 CLASS III** PAGE 25 / **DRIVERS & POWER SUPPLIES** PAGE 29 / **CONTROLLERS & ACCESORIES** PAGE 33



## FULL COLOUR SYSTEM

- 12 "Full colour" LEDs P5 1.2W RGB by SEOUL, each LED's case contains 3 dices
- Each LED's case contains RGB dices (3x1.2W)
- Best quality PMMA lenses, diameter 35mm
- RGB (Red – Green – Blue) colour mixing system
- Mix the primary colours to obtain colour combinations

## RGB AND WHITE DIMMER SYSTEM

- 36 high power LEDs 1.2W Xlamp by CREE
- RGB (Red – Green – Blue) colour mixing system or WHITE LEDs 5500K with dimmer function
- Mix the primary colours to obtain any colour combinations

## FEATURES

- Lumen maintenance of greater than 70% on average over 50,000 hours, not in extreme conditions
- Linear dimmer from 0 to 100%
- Incredible fast strobe effect
- Main voltage from 85Vac to 265Vac 50/60Hz
- Maximum consumption 44W
- Operating temperature from -30°C to 40°C
- Electronic board 8/16bit resolution with 4 digit LED display inside the projector
- Works via DMX signal (From 3 to 14 channels)
- Works in automatic mode
- Master / slave function

- IP40 protection rate for in -door use
- Adjustable double bracket for floor positioning with fixing holes
- Can be installed in any position
- Aluminium body with cooling fins
- Black finished (other colours on request)
- Plug for power supply (female included)
- XLR 3pin (5 pin on request) panel connectors for DMX signal
- Available with four different optical systems: 12°; 30°; 45° and 10x50° elliptical

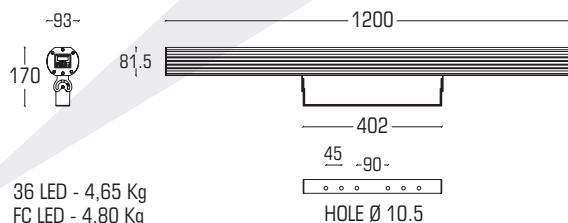





## FULL COLOUR SYSTEM

- 12 "Full colour" LEDs P5II 1.2W RGB by SEOUL, each LED's case contains 3 dices
- Each LED's case contains RGB dices (3x1.2W)
- Best quality PMMA lenses, diameter 35mm
- RGB (Red – Green – Blue) colour mixing system
- Mix the primary colours to obtain colour combinations

## RGB AND WHITE DIMMER SYSTEM

- 36 high power LEDs 1.2W Xlamp by CREE
- RGB (Red – Green – Blue) colour mixing system or WHITE LEDs 5500K with dimmer function
- Mix the primary colours to obtain any colour combinations

## FEATURES

- Lumen maintenance of greater than 70% on average over 50,000 hours, not in extreme conditions
- Linear dimmer from 0 to 100%
- Incredible fast strobe effect
- Main voltage from 85Vac to 265Vac 50/60Hz
- Maximum consumption 44W
- Operating temperature from -30°C to 40°C
- Electronic board 8/16bit resolution with 4 digit LED display inside the projector
- Works via DMX signal (From 3 to 14 channels)

- Works in automatic mode
- Master / slave function
- IP40 protection rate for in-door use
- Adjustable double bracket for floor positioning with fixing holes
- Can be installed in any position
- Aluminium body with cooling fins
- Black finished (other colours on request)
- Plug for power supply (female included)
- XLR 3pin (5 pin on request) panel connectors for DMX signal
- Available with three different optical systems: 12°; 30° and 45° lenses

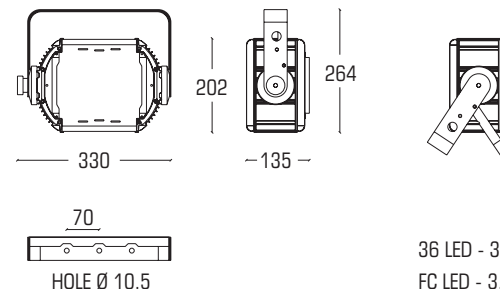



### FULL COLOUR SYSTEM

- L.B.3 LED is an in-door LED bar projector
- 3 "Full colour" LEDs P5 1.2W RGB by SEOUL, each LED's case contains 3 dices
- Each LED's case contains RGB dices (3x1.2W)
- Best quality PMMA lenses, diameter 35mm or aluminium reflector
- RGB (Red – Green – Blue) colour mixing system
- Mix the primary colours to obtain colour combinations

### RGB AND WHITE SYSTEM

- L.B.9 LED is an in-door LED bar projector
- 9 high power LEDs 1.2W Xlamp by CREE
- RGB (Red – Green – Blue) colour mixing system or WHITE LEDs 5500K
- Mix the primary colours to obtain any colour combinations

### FEATURES

- Lumen maintenance of greater than 70% on average over 50,000 hours, not in extreme conditions
- Maximum consumption 11W
- Operating temperature from -30°C to 40°C
- IP40 protection rate, in-door application
- Adjustable bracket with fixing holes
- Can be installed in any position
- Aluminium body
- White finished (other colours on request)

- The projector need to be completed with the LED Power RGB (DMX signal) or with the SOFT TOUCH system if you want to control the light intensity
- LED Power RGB can drive up to 4 L.B.9. colour changer or 4 L.B.9. White dimmer light
- The projector need to be completed with the standard LED drivers if you want the On/Off version
- The projector has RJ45 female panel connector
- Available with five different optical systems: 12°; 30°; 45°; 10x50° elliptical and 110° without lenses

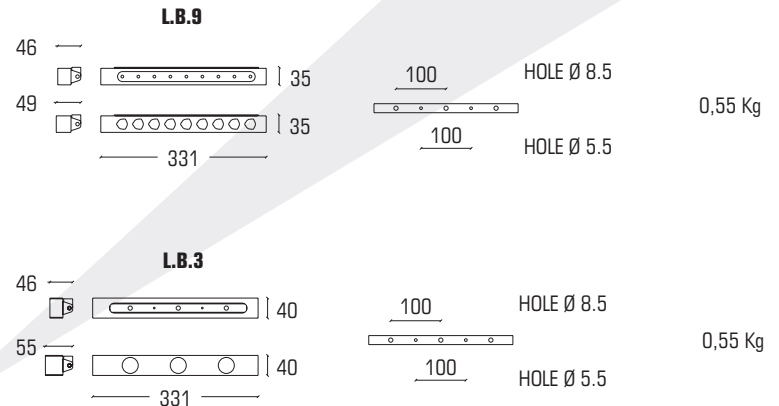





## RGB AND WHITE DIMMER SYSTEM

- 18 high power LEDs 1.2W Xlamp by CREE
- RGB (Red – Green – Blue) colour mixing system or WHITE LEDs 5500K with dimmer function
- Mix the primary colours to obtain any colour combinations

## FEATURES

- Recessed projector for false ceiling
- Lumen maintenance of greater than 70% on average over 50,000 hours, not in extreme conditions
- Linear dimmer from 0 to 100%
- Incredible fast strobe effect
- Main voltage from 85Vac to 265Vac 50/60Hz
- Maximum consumption 22W
- Operating temperature from -30°C to 40°C
- Electronic board 8/16bit resolution with 4 digit LED display placed in a separate box IP30
- Works via DMX signal (From 3 to 14 channels)
- Works in automatic mode
- Master / slave function
- IP40 protection rate, in-door applications
- Adjustable position of projector (+/- 60°)
- Aluminium and plastic body projector
- Protection front glass
- White finished (other colours on request)

- From 185mm to 190mm hole for false ceiling installation
- Two springs for false ceiling installation (included)
- The projector has 3.5m flexible cable with RJ45 plug (other on request)
- External box has connector for projector, XLR 3 pin (5 pin on request) for DMX signal and Plug for power supply (female included)
- Available with four different optical systems: 12°; 30°; 45° and 110° without lenses

## WHITE OR MONOCHROMATIC LIGHT ON/OFF

- White day-light LEDs 5500K (other on request)
- On/Off version

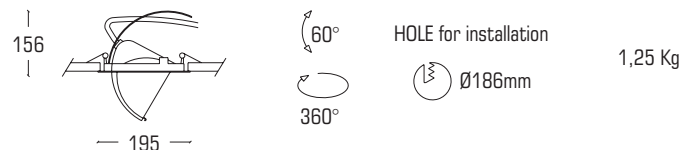

## LED Power rgb

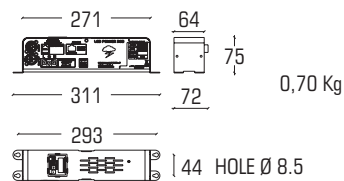

## LED Power On/Off

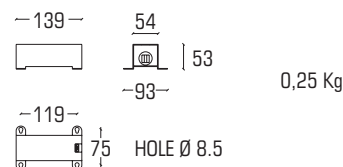

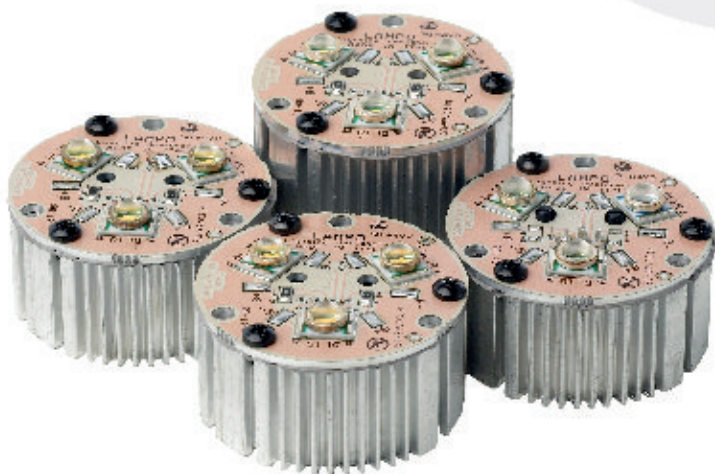

## RGB SYSTEM

- RGB (Red – Green – Blue) colour mixing system
- 3 high power LEDs 1.2W Xlamp by CREE
- Mix the primary colours to obtain any colour combinations
- The projector has RJ45 female panel connector

## WHITE SYSTEM

- White day-light 5500K, natural white 4200K or warm white 3200K LEDs
- 3 high power LEDs 1.2W Xlamp by CREE
- The projector has RJ45 female panel connector or 50cm black/red cables

## FEATURES

- LED projector
- Lumen maintenance of greater than 70% on average over 50,000 hours, not in extreme conditions
- Maximum consumption 3,6W
- Operating temperature from -30°C to 40°C
- Can be installed in any position
- Aluminium extruded for heat dissipation, fixing rear holes
- The projector need to be completed with the LED Power RGB (DMX signal) or with the SOFT TOUCH system if you want to control the intensity of light
- LED Power RGB can drive up to 10 LED projector

- The projector need to be completed with the standard LED drivers if you want the On/Off version
- The projector is sold without lenses (very wide beam)
- Available 5 type of lenses: 6° Narrow; 25° Medium; 45° Wide beam; 110° milky white or 110° clear white

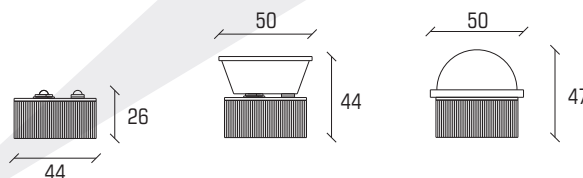
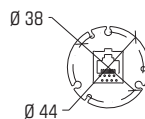

0,07 Kg





## RGB SYSTEM

- RGB (Red – Green – Blue) colour mixing system
- 3 high power LEDs 1.2W Xlamp by CREE
- Mix the primary colours to obtain any colour combinations
- The projector has RJ45 female panel connector

## WHITE SYSTEM

- White day-light 5500K, natural white 4200K or warm white 3200K LEDs
- 3 high power LEDs 1.2W Xlamp by CREE
- The projector has RJ45 female panel connector or 50cm black/red cables

## FEATURES

- False ceiling recessed LED projector
- Lumen maintenance of greater than 70% on average over 50,000 hours, not in extreme conditions
- Maximum consumption 3,6W
- Operating temperature from -30°C to 40°C
- IP40 protection rate, for any in-door applications
- Adjustable position
- Can be installed on false ceiling
- Fixing hole from 81 to 85mm
- Aluminium extruded for heat dissipation
- Aluminium body
- White finished (other colours on request)

- The projector need to be completed with the LED Power RGB (DMX signal) or with the SOFT TOUCH system if you want to control the intensity of light
- LED Power RGB can drive up to 10 LED projector
- The projector need to be completed with the standard LED drivers if you want the On/Off version
- Available 5 type of lenses: 6° Narrow; 25° Medium; 45° Wide beam; 110° milky white or 110° clear white

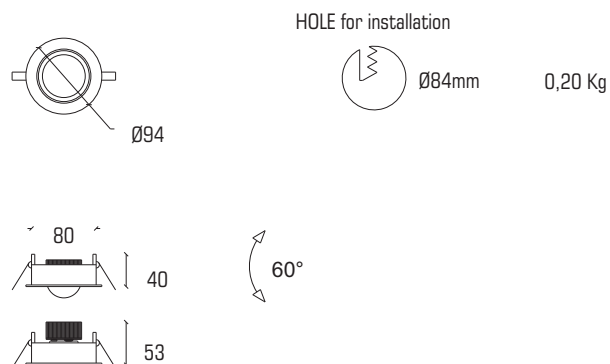



## RGB SYSTEM

- RGB (Red – Green – Blue) colour mixing system
- 3 high power LEDs 1.2W Xlamp by CREE
- Mix the primary colours to obtain any colour combinations
- The projector has RJ45 female panel connector

## WHITE SYSTEM

- White day-light 5500K, natural white 4200K or warm white 3200K LEDs
- 3 high power LEDs 1.2W Xlamp by CREE
- The projector has RJ45 female panel connector

## FEATURES

- In-door LED projector
- Lumen maintenance of greater than 70% on average over 50,000 hours, not in extreme conditions
- Maximum consumption 3,6W
- Operating temperature from -30°C to 40°C
- IP40 protection rate, for any in-door applications
- Adjustable bracket with fixing holes
- Can be installed in any position
- Aluminium extruded for heat dissipation
- Aluminium body
- White finished (other colours on request)
- The projector need to be completed with the LED Power RGB (DMX signal) or

- with the SOFT TOUCH system if you want to control the intensity of light
- LED Power RGB can drive up to 10 LED projector
- The projector need to be completed with the standard LED drivers if you want the On/Off version
- Available 5 type of lenses: 6° Narrow; 25° Medium; 45° Wide beam; 110° milky white or 110° clear white

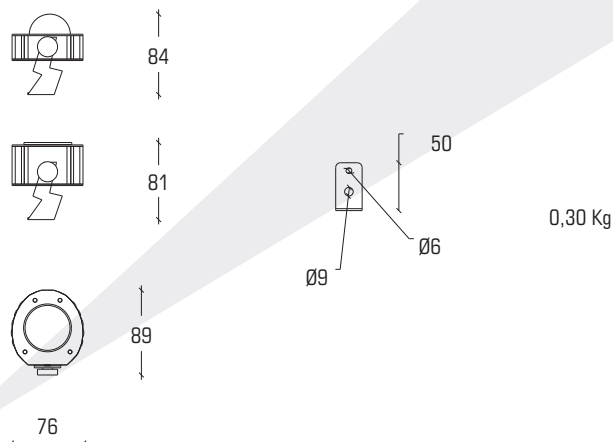



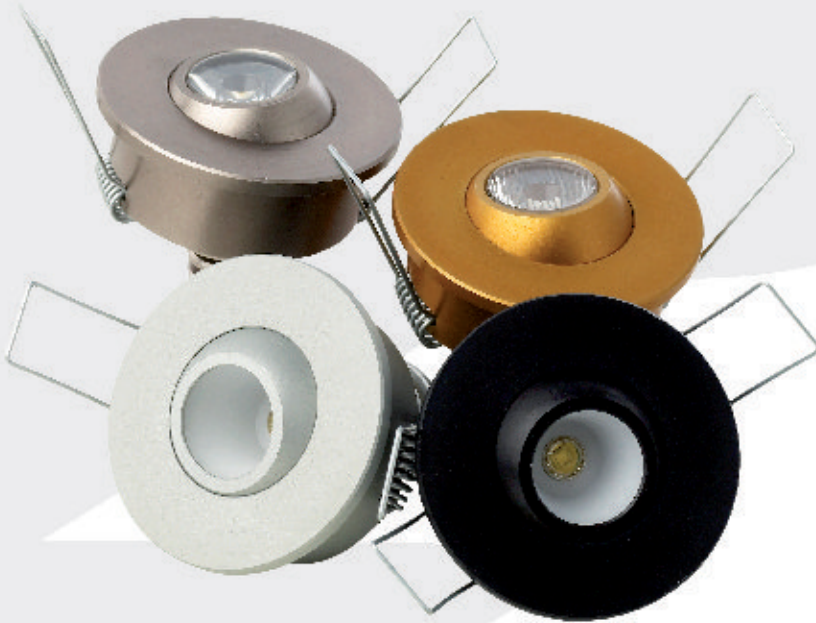

## MONOCHROMATIC SYSTEM

- Single LED projectors
- 1 high power LEDs 1.2W/3W Xlamp by CREE
- Best quality PMMA lenses diameter 19mm, parabolic reflector or teflon lenses

## FEATURES

- Very smart false ceiling recessed LED projector
- Lumen maintenance of greater than 70% on average over 50,000 hours, not in extreme conditions
- Maximum consumption ( 1,2W @ 350mA or 2,5W @ 700mA )
- Operating temperature from -30°C to 40°C
- IP40 protection rate, for any in-door applications
- Adjustable position
- Can be installed on false ceiling
- Fixing hole from 41 to 45mm
- Aluminium body for heat dissipation
- Available in different anodization colours: black, white, dark grey and gold (other colours on request)
- Available with different led colours:
  - Cold White 5500K
  - Natural White 4200K
  - Warm White 3200K
  - Blue
  - Green
  - Red
  - Amber
- The projector need to be completed with the LED Power RGB (DMX signal) or with the SOFT TOUCH system if you want to control the light intensity
- The projector need to be completed with the standard LED drivers if you want the On/Off version
- Available with 6 type of lenses: 6° Narrow; 25° Medium; 45° Wide beam; 90° Very wide beam; 10x50° Elliptical beam and 8° Parabolic Reflector

HOLE for installation



Ø43mm

0,06 Kg



44



30°

41

Ø49



360°

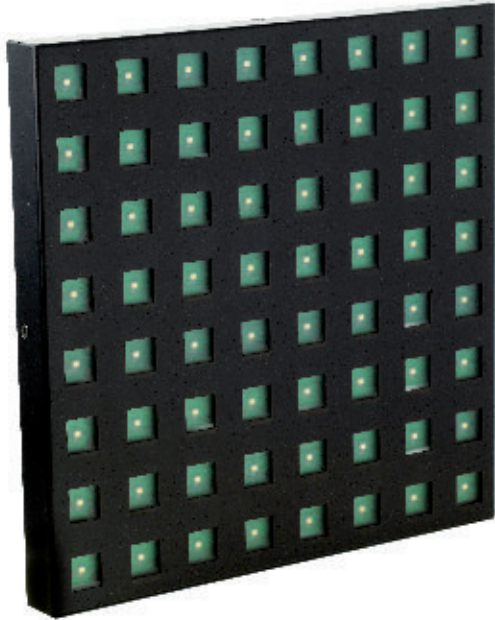

## i PIX64

- Slim module with 64 white LEDs
- Electronic board inside the module
- Works via DMX signal (From 8 to 64 channels)
- Possibility to create large screens (modular)
- Possibility to control every single LED separately (8 bit resolution each LED)
- Easy DMX assignement with the "auto-learning"
- Suitable for architectural applications and general use
- IP40 protection rate
- Aluminium and steel body projector
- Anodised black or white surface
- Ta max (in-door) 40°C - Ta min -20°
- Power connection block for power supply inside
- DMX signal connection block inside
- 64 Topled white by Seoul Semiconductor, 20mA
- Main supply: 12V DC
- Consumption: max 32W
- Lampo uses Light Factory software to control the iPIX64
- Lampo uses PLUS 2048 to interface PC software with up to 32 independent modules and to record the scenes
- It is possible to use any type of DMX consolle or software
- i PIX64 need to be completed with the power switching (not included)

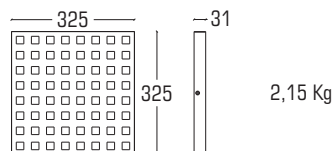

## DIODE FULLBAR

- Slim and versatile colour changer bar
- 10 FullColour LEDs 0,18W by Seoul
- Possibility to control every single LED in rgb mode separately (24 bit resolution each LED)
- Possibility to create screens or long bars
- Works via DMX signal (30 channels)
- Male/Female connectors (with DMX and Power ) for cascade connection included
- Max length of the chain 6 meters
- Adjustable aluminium bracket for installation
- Easy DMX assignement with "auto-learnig" or via consolle
- IP20 protection rate
- Ta max (in-door) 40°C - Ta min -20°
- Main supply 24Vdc
- Maximum consumption 6 W
- It is possible to use any type of DMX consolle or software
- Diode FULLBAR need to be completed with the power switching (not included)
- Lampo uses Light Factory software to control Diode FULLBAR
- Lampo uses PLUS 2048 to interface PC software with up to 32 independent modules and to record the scenes



# STRIP LED & STRIP LED POWER

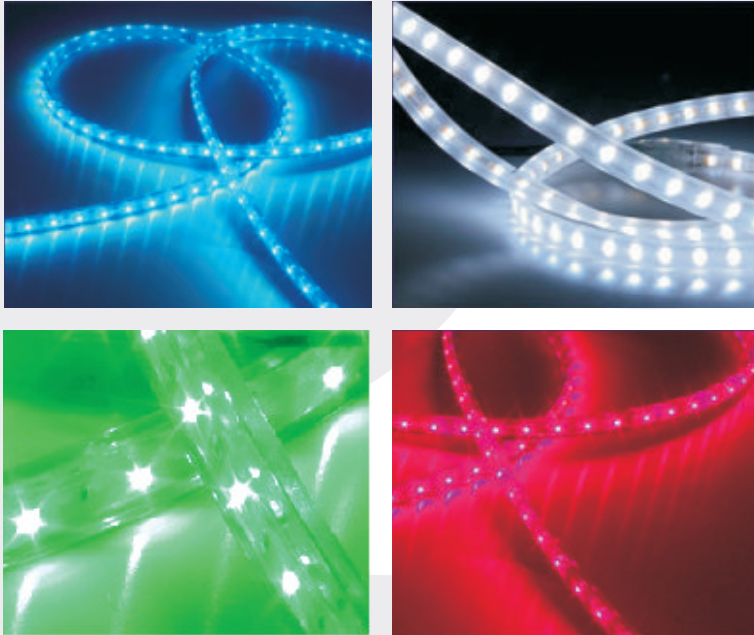

## STRIP LED FULL COLOUR SYSTEM

- "Full colour" LEDs, each LED's case contains 3 dices
- RGB (Red—Green—Blue) colour mixing system
- Mix the primary colours to obtain colour combinations
- Available in: 20, 30, 40, 50, 70, 100 LED/meter configuration

## MONOCHROMATIC SYSTEM

- Monochromatic LED with dimmer or ON/OFF function
- Made in different colours and LED/meter configuration
- Available also with side emitting LEDs (natural and warm white excluded)
- Available leds colours:
  - Cold White 5500K
  - Natural White 4200K
  - Warm White 3200K
  - Blue
  - Green
  - Red
  - Amber
- Available in: 10, 20, 33, 40, 50, 100 LED/meter configuration

## FEATURES

- Strip LED are a linear lighting system
- 120° beam angle (very wide)
- Input voltage 24VDC

- The strips are made on special material, and also have an adhesive side on the bottom
- The strips need to be completed with the drivers (not included)
- Available different extruded aluminium profiles with two different polycarbonate covers

## STRIP LED POWER rgb

- Dedicated driver for STRIPS LED
- Control the intensity of red, green, blue channels for RGB strips
- Control the intensity of LED for MONOCHROMATIC strips
- Monochromatic strips must be driven with 24Vdc power switching for the ON/OFF version
- STRIP LED POWER drives up to 72W of strip
- Works via DMX signal (8 channels) or in automatic mode
- Main voltage 24Vdc

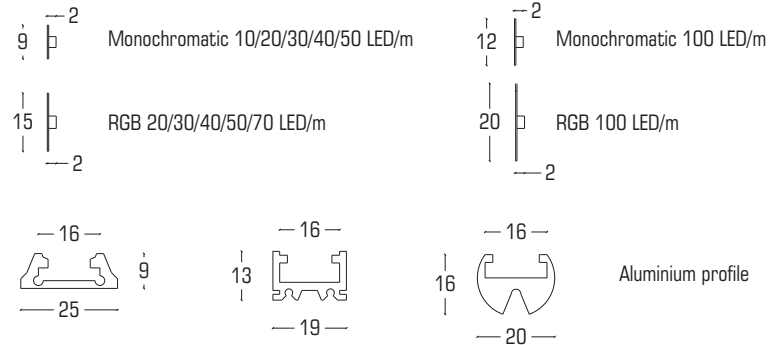

## STRIP LED POWER

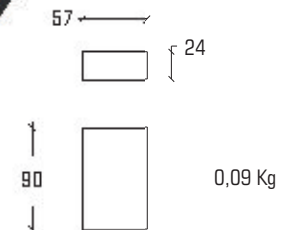
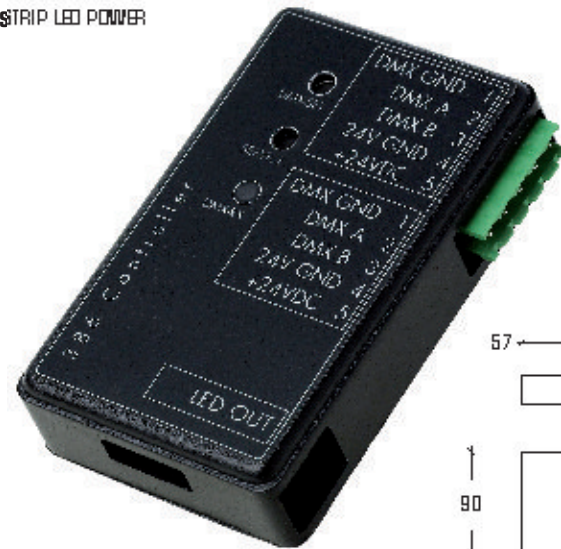



A black outdoor lighting fixture is shown being tested with high-pressure water spray. The water is splashing over the fixture, demonstrating its waterproof capabilities. The fixture has a textured, ribbed surface and a lens that is partially obscured by the water. The background is dark, making the white water spray stand out.

**OUT-DOOR SOLUTIONS IP66/IP65**

**LAMPO LIGHTING DESIGNERS / LED TECHNOLOGY AND ARCHITECTURAL LIGHTING / 2009**



## FULLCOLOUR SYSTEM

- Single intelligent LED projector
- 1 "Full colour" LED P5II 1.2W RGB by SEOUL, the LED's case contains 3 dices
- The LED's case contains RGB dices (3x1.2W)
- Best quality PMMA lens diameter 35mm

## FEATURES

- It uses only one 2-wire-cable (DMX signal on power line)
- Lumen maintenance of greater than 70% on average over 50,000 hours, not in extreme conditions
- Linear dimmer from 0 to 100%
- Incredible fast strobe effect
- Main voltage 24Vdc
- Electronic board inside the projector
- Works via DMX signal (8 channels)
- Maximum consumption (3,6W)
- Operating temperature from -30°C to 40°C
- IP65 protection rate, suitable for any out-door applications
- Can be installed in any position
- Aluminium body for heat dissipation
- Stainless steel external screw
- Black anodized finished
- The projector need to be completed with the D.R.A.R. Power Box
- Cable clamps PG9 for DMX signal and power with 1 meter cable with Wieland plugs male and female (IN/OUT system)
- Available with 3 type of lenses: 6° Narrow; 25° Medium; 45° Wide beam

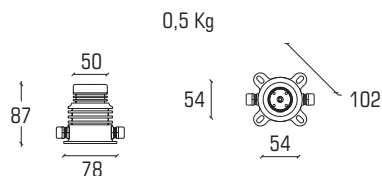

## D.R.A.R. POWER BOX

- New generation of power box
- Controllable via DMX with RDM functions
- Controllable via ArtNet
- ArtNet to DMX
- DMX to ArtNet
- Artnet and DMX recording capabilities
- Artnet and DMX Playback capabilities (Scenes stored on SD card)
- Can control up to 32 PIN LED with only one 2-wire-cable (DMX signal on power line)
- Main voltage: 24Vdc
- IP30 protection rate
- Aluminium box
- Black colour finished
- Plug for power supply (female included)
- Plug for PIN SPOT LED supply
- RJ45 female connector for ArtNet signal
- XLR 5 pin for DMX signal
- Slot for SD card

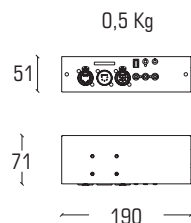





## FULL COLOUR SYSTEM

- 100 "Full colour" LEDs P5II 1.2W RGB by SEOUL, each LED's case contains 3 dices
- Each LED's case contains RGB dices (3x1.2W)
- Best quality PMMA lenses, diameter 35mm
- RGB (Red – Green – Blue) colour mixing system
- Mix the primary colours to obtain colour combinations

## FEATURES

- Lumen maintenance of greater than 70% on average over 50,000 hours, not in extreme conditions
- Linear dimmer from 0 to 100%, incredible fast strobe effect
- Main voltage from 85Vac to 265Vac 50/60Hz
- Maximum consumption 360W
- Operating temperature from -30°C to 40°C
- Electronic boards 8/16bit resolution with 4 digit LED display inside the projector
- CENTURY has ten electronic boards, it is possible to set all LED rows with the same DMX address or to set 10 LED rows with different DMX address (can be controlled independently)
- Works via DMX signal (From 3 to 14 channels each electronic board)
- Works in automatic mode
- Master / slave function
- IP65 protection rate
- Adjustable bracket with fixing holes
- Can be installed in any position
- Aluminium and steel body with cooling fins
- Grey colour finished (other colours on request)
- Tempered front glass (IK09)
- Silicone rubber gaskets
- Cable clamps PG13.5 with 1 meter cable for each power supply in/out with IP65 plugs Weiland RST 20i3 included
- Cable clamps PG9 plus 0.5meter cable for DMX signal in/out with IP65 plug Neutrik NC3 X-HD 3pin included
- On request is available an adjustable bracket with handles, for floor positioning
- Available with three optical systems: 12°; 30° and 45° lenses

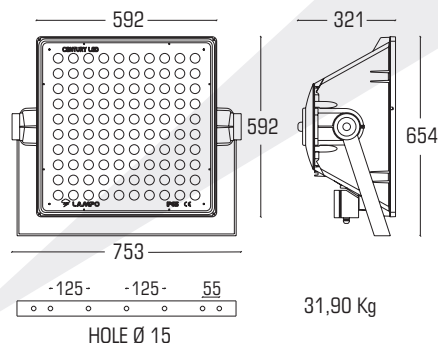





## FULL COLOUR SYSTEM

- 12 "Full colour" LEDs P5 1.2W RGB by SEOUL, each LED's case contains 3 dices
- Each LED's case contains RGB dices (3x1.2W)
- Best quality PMMA lenses, diameter 35mm or aluminium reflector
- RGB (Red – Green – Blue) colour mixing system
- Mix the primary colours to obtain colour combinations

## RGB and WHITE DIMMER SYSTEM

- 36 high power LEDs 1.2W Xlamp by CREE
- RGB (Red – Green – Blue) colour mixing system or WHITE LED 5500K with dimmer function
- Mix the primary colours to obtain any colour combinations

## FEATURES

- Out-door wallwashing colour changer bar
- Lumen maintenance of greater than 70% on average over 50,000 hours, not in extreme conditions
- Linear dimmer from 0 to 100%
- Incredible fast strobe effect
- Main voltage from 85Vac to 265Vac 50/60Hz
- Maximum consumption 44W
- Operating temperature from -30°C to 40°C
- Electronic board 8/16bit resolution with 4 digit LED display inside the projector
- Works via DMX signal (From 3 to 14 channels)

- Works in automatic mode
- Master / slave function
- IP65 protection rate
- Adjustable bracket with fixing holes
- Can be installed in any position
- Aluminium body with cooling fins
- Stainless steel external screws
- Silicone rubber gaskets
- Tempered protection glass (IK08)
- Grey finished (other colours on request)
- Cable clamps M20 with 1 meter cables for each power supply in/out with IP65 plugs Weiland RST 20i3 (male and female plug included)
- Cable clamps PG9 plus 0.5 meter cables for DMX signal in/out with IP65 plugs Neutrik NC3 X-HD 3pin
- Available with five optical systems: 12°; 30°; 45°; 10x50° elliptical and 110° without lenses

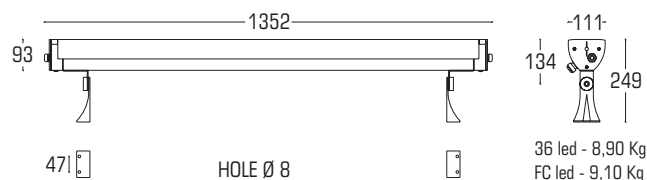



## FULL COLOUR SYSTEM

- 40 "Full colour" LEDs P5 1.2W RGB by SEOUL, each LED's case contains 3 dices
- Each LED's case contains RGB dices (3x1.2W)
- Best quality PMMA lenses, diameter 27mm
- RGB (Red – Green – Blue) colour mixing system
- Mix the primary colours to obtain colour combinations

## FEATURES

- Powerful out-door colour changer
- Lumen maintenance of greater than 70% on average over 50,000 hours, not in extreme conditions
- Linear dimmer from 0 to 100%
- Incredible fast strobe effect
- Main voltage: 230Vac 50Hz
- Maximum consumption 144W
- Operating temperature from -30°C to 40°C
- Electronic board inside the projector
- Works via DMX signal (8 channels)
- Works in automatic mode
- IP66 protection rate
- Adjustable steel bracket with fixing holes
- Can be installed in any position
- Aluminium and steel body with cooling fins
- Stainless steel external screw
- Tempered front glass (IK07)
- Grey colour finished (other colours on request)
- Cable clamp PG13.5 for power supply
- Two cable clamps PG9 for DMX signal cables
- Available with two optical systems: 30° and 45° lenses

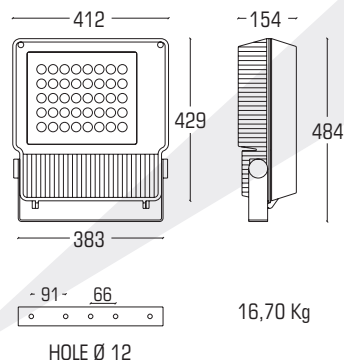



## FULL COLOUR SYSTEM

- 12 "Full colour" LEDs P5II 1.2W RGB by SEOUL, each LED's case contains 3 dices
- Each LED's case contains RGB dices (3x1.2W)
- Best quality PMMA lenses, diameter 35mm or aluminium reflector
- RGB (Red – Green – Blue) colour mixing system
- Mix the primary colours to obtain colour combinations
- Maximum consumption 44W

## RGB AND WHITE DIMMER SYSTEM

- Available with 18 or 36 high power LEDs 1.2W Xlamp by CREE
- RGB (Red – Green – Blue) colour mixing system or WHITE LEDs 5500K with dimmer function
- Mix the primary colours to obtain any colour combinations
- Maximum consumption 22W (18LED) or 44W (36LED)

## FEATURES

- Out-door versatile colour changer
- Lumen maintenance of greater than 70% on average over 50,000 hours, not in extreme conditions
- Linear dimmer from 0 to 100%
- Incredible fast strobe effect
- Main voltage from 85Vac to 265Vac 50/60Hz
- Operating temperature from -30°C to 40°C
- Electronic board 8/16bit resolution with 4 digit LED display, inside the projector
- Works via DMX signal (from 3 to 14 channels)

- Works in automatic mode
- Master / slave function
- IR sensor for remote control
- IP66 protection rate
- Adjustable bracket with fixing holes
- Can be installed in any position
- Aluminium and steel body with cooling fins
- Stainless steel external screw
- Tempered front glass (IK08)
- Grey colour finished (other colours on request)
- Cable clamp PG13.5 for power supply
- Two cable clamps PG9 for DMX signal cable
- Available with four optical systems: 12°; 30°; 45° and 110° without lenses

## WHITE OR MONOCHROMATIC LIGHT ON/OFF

- White day-light LEDs 5500K (other on request)
- On/Off version
- Cable clamp PG13.5 for power supply

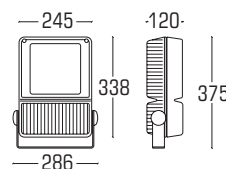

18 led - 4,90 Kg  
 36 led - 5,90 Kg  
 FC led - 6,10 Kg





## FULL COLOUR SYSTEM

- 12 "Full colour" LEDs P5II 1.2W RGB by SEOUL, each LED's case contains 3 dices
- Each LED's case contains RGB dices (3x1.2W)
- Best quality PMMA lenses, diameter 35mm or aluminium reflector
- RGB (Red – Green – Blue) colour mixing system
- Mix the primary colours to obtain colour combinations

## RGB AND WHITE DIMMER SYSTEM

- 36 high power LEDs 1.2W Xlamp by CREE
- RGB (Red – Green – Blue) colour mixing system or WHITE LEDs 5500K with dimmer function
- Mix the primary colours to obtain any colour combinations

## FEATURES

- Innovative projector, mainly suitable for trusses
- Lumen maintenance of greater than 70% on average over 50,000 hours, not in extreme conditions
- Linear dimmer from 0 to 100%
- Incredible fast strobe effect
- Main voltage from 85Vac to 265Vac 50/60Hz
- Maximum consumption 44W
- Operating temperature from -30°C to 40°C
- Electronic board 8/16bit resolution with 4 digit LED display placed in separate aluminium box IP65

- Works via DMX signal (From 3 to 14 channels)
- Works in automatic mode
- Master / slave function
- IP65 protection rate
- Adjustable aluminium bracket
- Can be installed in any position
- Aluminium body with cooling fins
- Stainless steel external screw
- Tempered front glass (IK08)
- Grey finished (other on request)
- The separate box has cable clamp PG13.5 for power supply, two cable clamps PG9 for DMX signal cable and cable clamp for projector's cable
- The projector comes with 3.5m flexible cable included (other on request)
- Available with four different optical systems: 12°; 30°; 45° and 110° without lenses

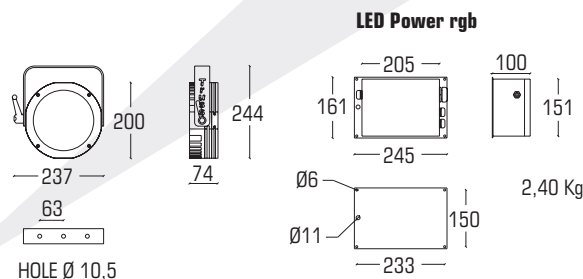

36 led - 3,55 Kg  
FC led - 3,75 Kg



## RGB AND WHITE DIMMER SYSTEM

- RGB (Red – Green – Blue) colour mixing system
- White day-light 5500K, natural white 4200K or warm white 3200K LEDs
- 3 high power LEDs 1.2W Xlamp by CREE
- Mix the primary colours to obtain any colour combinations
- The projector has RJ45 female panel connector

## FEATURES

- Out-door LED projector, suitable for gardens
- Lumen maintenance of greater than 70% on average over 50,000 hours, not in extreme conditions
- Maximum consumption 3,6W
- Operating temperature from -30°C to 40°C
- IP65 protection rate
- Tempered front glass
- Aluminium extruded for heat dissipation
- Aluminium body
- Stainless steel external screw
- Grey finished (other colour on request)
- The projector need to be completed with the LED Power RGB (DMX signal) or with the SOFT TOUCH system if you want to control the light intensity
- LED Power RGB can drive up to 10 LED projector
- Cable clamp for LED supply
- Available 4 type of lenses: 6° Narrow; 25° Medium; 45° Wide beam and 110° Very Wide beam

## WHITE SYSTEM (In-built power supply included)

- White day-light 5500K, natural white 4200K or warm white 3200K LEDs
- 3 high power LEDs 1.2W Xlamp by CREE
- The projector has power unit inside: 230Vat 50/60Hz
- On/Off version

1,00 Kg

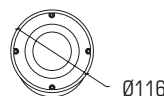
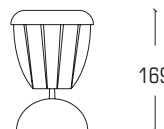
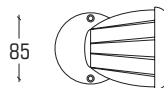

HOLE Ø 6.5



- Powerful discharge lamp colour changer
- Designed for CDM/SA-T 150W discharge lamp, G12 socket
- Ideal for out-door architectural application and special exhibitions
- IP66 protection rate (not for immersion!)
- Main supply: 230V 50Hz (other on request)
- Consumption: 1.2A at 230V with p.f.c.
- Built-in magnetic ballast
- Ta from -10°C to 30°C
- High efficiency aluminium reflector
- Tempered front glass
- Aluminium body with cooling fins
- Diffused light colour changer, 50° beam angle
- CYM (Cyan – Yellow – Magenta) colour mixing system
- Infinity colour combination
- Linear dimmer from 0 to 100%
- Shutter and strobe
- Intelligent control panel with 4-digit LED display
- Works via DMX512 signal (6 channels)
- Works in complete stand alone mode
- Master / slave function
- PG13.5 cable clamp for power supply
- 2 x PG9 cable clamps for DMX signal

### Recommended lamp:

- CDM-SA/T 150 4200K 6000hrs 14700Lum

### Alternative:

- CDM-T 150 3000K 6000hrs 13000Lum
- CDM-T 150 4200K 6000hrs 14000Lum
- HCI-T 150 3000K 6000hrs 13000Lum
- HCI-T 150 4200K 6000hrs 14000Lum

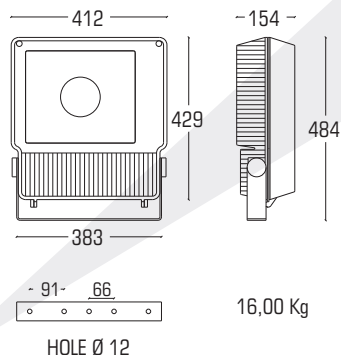



A close-up photograph of a recessed LED lighting fixture. The fixture is circular and features a grid of multi-colored LEDs (red, green, blue, and white) arranged in a honeycomb pattern. The fixture is mounted in a ceiling, and the surrounding ceiling material is visible, showing a grid of recessed sections. The lighting is dim, with the LEDs providing the primary illumination. The overall aesthetic is modern and architectural.

## IN-GROUND SOLUTIONS IP67

LAMPO LIGHTING DESIGNERS / LED TECHNOLOGY AND ARCHITECTURAL LIGHTING / 2009

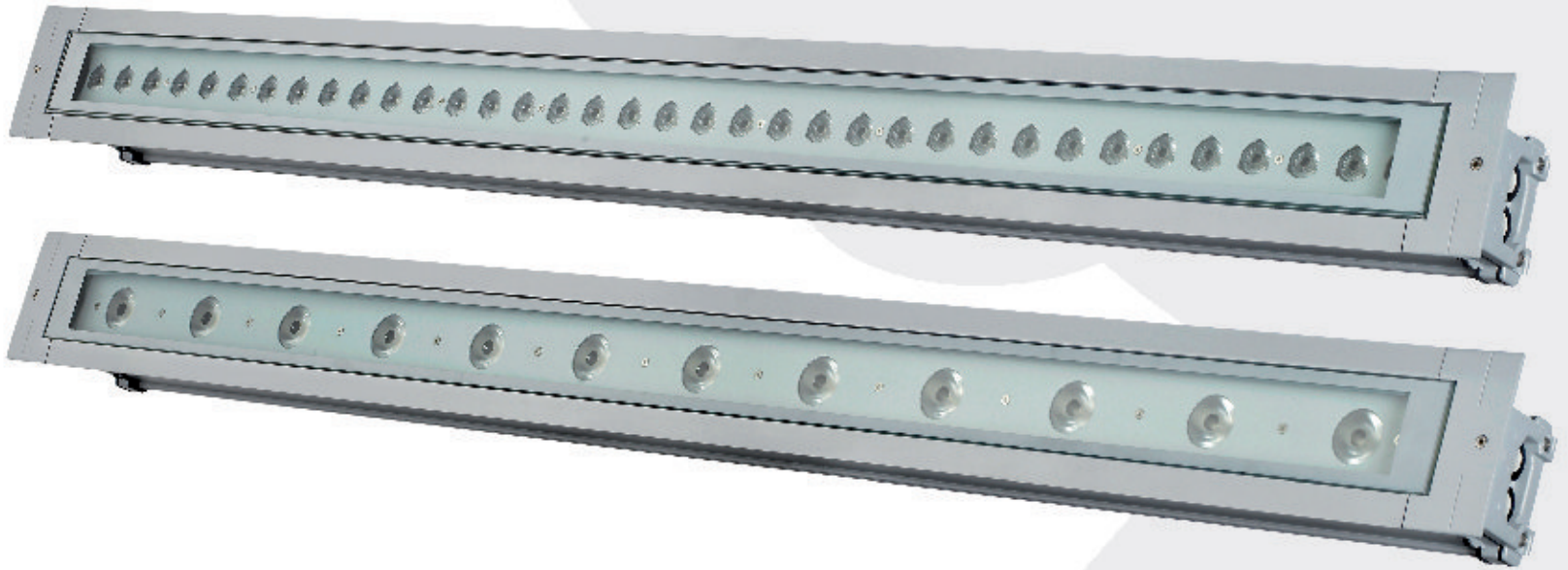

## FULL COLOUR SYSTEM

- 12 "Full colour" LEDs P5 1.2W RGB by SEDUL, each LED's case contains 3 dices
- Each LED's case contains RGB dices (3x1.2W)
- Best quality PMMA lenses, diameter 35mm or aluminium reflector
- RGB (Red – Green – Blue) colour mixing system
- Mix the primary colours to obtain colour combinations

## RGB AND WHITE DIMMER SYSTEM

- 36 high power LEDs 1.2W Xlamp by CREE
- RGB (Red – Green – Blue) colour mixing system or WHITE LEDs 5500K with dimmer function
- Mix the primary colours to obtain any colour combinations

## FEATURES

- In-ground recessed colour changer
- Lumen maintenance of greater than 70% on average over 50,000 hours, not in extreme conditions
- Linear dimmer from 0 to 100%
- Incredible fast strobe effect
- Main voltage from 85Vac to 265Vac 50/60Hz
- Maximum consumption 44W
- Operating temperature from -30°C to 40°C
- Electronic board 8/16bit resolution with 4 digit LED display inside the projector
- Works via DMX signal (From 3 to 14 channels)
- Works in automatic mode
- Master / slave function

- IP67 protection rate
- Aluminium body
- Stainless steel external screw
- Tempered glass (walk over) up to 1000Kg static load (IK10)
- Grey finished (other colours on request)
- Two cable clamps M16 for power supply
- Two cable clamps PG9 for DMX signal cables
- In-ground metal housing included
- Available with five optical systems: 12°; 30°; 45°; 10x50° elliptical and 110° without lenses

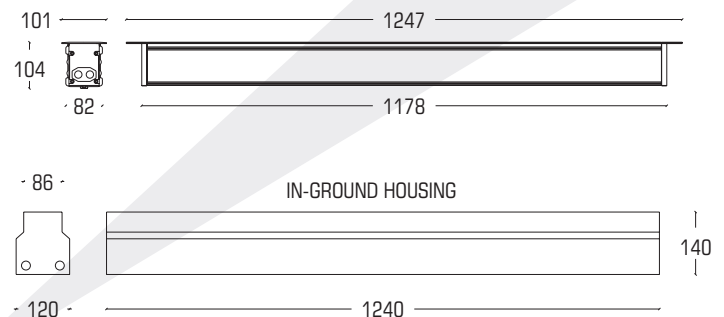



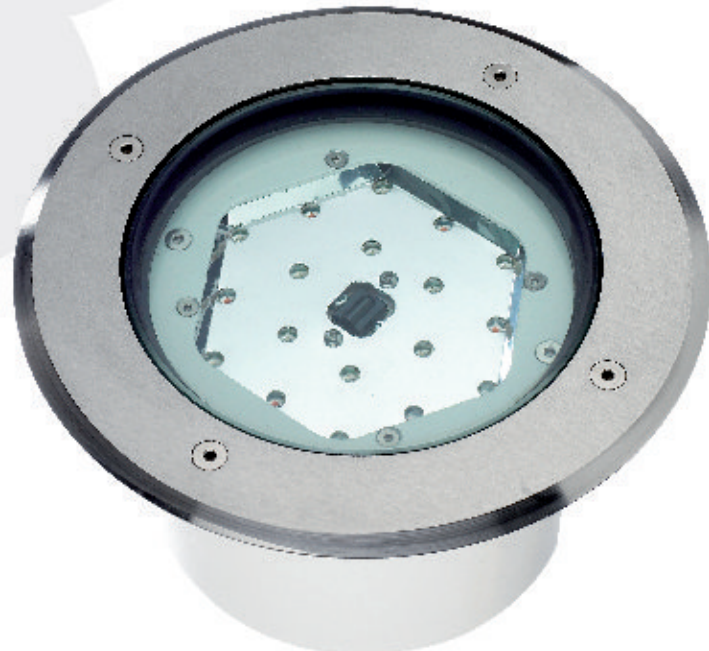

## RGB SYSTEM

- 18 high power LEDs 1.2W X lamp by CREE
- RGB (Red – Green – Blue) colour mixing system
- Mix the primary colours to obtain any colour combinations

## FEATURES

- In-ground recessed colour changer projector
- Lumen maintenance of greater than 70% on average over 50,000 hours, not in extreme conditions
- Linear dimmer from 0 to 100%
- Incredible fast strobe effect
- Main voltage from 85Vac to 265Vac 50/60Hz
- Maximum consumption 22W
- Operating temperature from -30°C to 40°C
- Electronic board 8/16bit resolution with 4 digit LED display allocated in separate aluminium box IP65
- Works via DMX signal (From 3 to 14 channels)
- Works in automatic mode
- Master / slave function
- IP67 protection rate
- Aluminium body with inox ring
- White colour finished (projector body)
- Polished inox ring
- Stainless steel external screw
- Tempered glass (IK10)

- Up to 2000Kg static load (20Km/h vehicles with tyres)
- The separate box has cable clamp PG13.5 for power supply, two cable clamps PG9 for DMX signal cable and cable clamp for projector's cable
- The projector comes with 3.5m flexible cable included (other on request)
- Plastic housing for inground installation included
- Available with four optical systems: 12°; 30°; 45° lenses and 110° without lenses

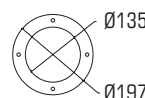

2,55 Kg

PLASTIC HOUSING

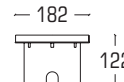

HOLE for installation

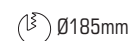

LED Power rgb

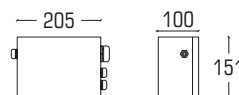

2,40 Kg





## RGB SYSTEM

- RGB (Red – Green – Blue) colour mixing system
- 3 high power LEDs 1.2W Xlamp by CREE
- Mix the primary colours to obtain any colour combinations
- The projector has RJ45 female panel connector

## WHITE SYSTEM

- White day-light 5500K, natural white 4200K or warm white 3200K LEDs
- 3 high power LEDs 1.2W Xlamp by CREE
- The projector has RJ45 female panel connector

## FEATURES

- In-ground recessed LED projector
- Lumen maintenance of greater than 70% on average over 50,000 hours, not in extreme conditions
- Maximum consumption 3,6W
- Operating temperature from -30°C to 40°C
- IP67 protection rate (walk over)
- Aluminium extruded for heat dissipation
- Aluminium body with inox ring
- White finished (projector body)
- Polished inox ring
- Stainless steel external screw
- The projector need to be completed with the LED Power RGB (DMX signal) or

- with the SOFT TOUCH system if you want to control the light intensity
- LED Power RGB can drive up to 10 LED projectors
- The projector need to be completed with the standard LED drivers if you want the On/Off version
- Plastic housing for in-ground installation is included
- PG9 cable clamp for LED supply
- Available 5 type of lenses: 6° Narrow; 25° Medium; 45° Wide beam; 110° milky white or 110° clear white

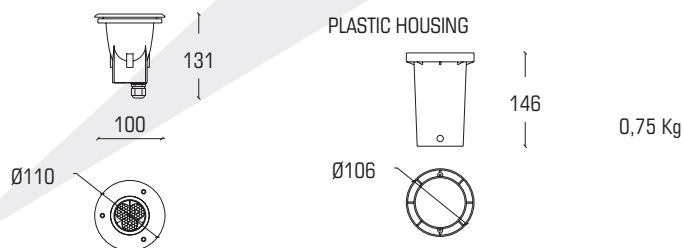



**UNDERWATER SOLUTIONS IP68 CLASS III**

LAMPO LIGHTING DESIGNERS / LED TECHNOLOGY AND ARCHITECTURAL LIGHTING / 2009





## RGB SYSTEM

- 18 high power LEDs 1.2W Xlamp by CREE
- RGB (Red – Green – Blue) colour mixing system
- Mix the primary colours to obtain any colour combinations

## FEATURES

- Underwater colour changing projector suitable for fountains
- Lumen maintenance of greater than 70% on average over 50,000 hours, not in extreme conditions
- Linear dimmer from 0 to 100%
- Incredible fast strobe effect
- Fixture Voltage 24 Vdc
- IP65 power box included with main voltage 230Vac 50Hz (other on request)
- Maximum consumption 22W
- Operating temperature from 0°C to 40°C
- Works via DMX signal (8 channels)
- Works in automatic mode
- IP68 protection rate (class III)
- Plastic body
- Stainless steel external screw
- Black colour finished
- The separate box has cable clamp PG13.5 for power supply, two cable clamps PG9 for DMX signal cable and cable clamp for projector's cable
- The projector comes with 5m flexible cable included (other on request)
- Available with four optical systems: 12°; 30°; 45° and 110° without lenses



1,40 Kg



LED Power rgb

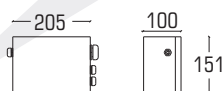

2,60 Kg





## RGB SYSTEM

- RGB (Red – Green – Blue) colour mixing system
- 3 high power LEDs 1.2W Xlamp by CREE
- Mix the primary colours to obtain any colour combinations

## WHITE SYSTEM

- White day-light 5500K, natural white 4200K or warm white 3200K LEDs
- 3 high power LEDs 1.2W Xlamp by CREE

## FEATURES

- Underwater LED projector suitable for fountains
- Lumen maintenance of greater than 70% on average over 50,000 hours, not in extreme conditions
- Maximum consumption 3,6W
- Operating temperature from 0°C to 40°C
- IP68 protection rate (class III)
- Tempered front glass
- Aluminium extruded for heat dissipation
- Inox body with inox ring
- Polished body
- Stainless steel external screw
- The projector need to be completed with the LED Power RGB for IMMERSION LED (DMX signal) or with the SOFT TOUCH system if you want to control the light intensity

- LED Power RGB for IMMERSION LED can drive up to 5 LED projector
- The projector need to be completed with LED drivers (with max 24Vcd out) if you want the On/Off version of projectors
- M16 cable clamp for LED supply
- The projector comes with 6m cable included
- Available 4 type of lenses: 6° Narrow; 25° Medium; 45° Wide beam and 110° Very Wide beam

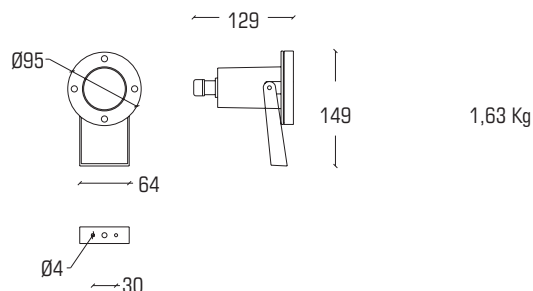



## RGB SYSTEM

- RGB (Red – Green – Blue) colour mixing system
- 3 high power LEDs 1.2W Xlamp by CREE
- Mix the primary colours to obtain any colour combinations

## WHITE SYSTEM

- White day-light 5500K, natural white 4200K or warm white 3200K LEDs
- 3 high power LEDs 1.2W Xlamp by CREE

## FEATURES

- Underwater LED projector, suitable for swimming-pools
- Lumen maintenance of greater than 70% on average over 50,000 hours, not in extreme conditions
- Maximum consumption 3,6W
- Operating temperature from 0°C to 40°C
- IP68 protection rate (class III)
- Tempered front glass
- Aluminium extruded for heat dissipation
- Inox body with inox ring
- Polished body
- Stainless steel external screw
- The projector need to be completed with the LED Power RGB for IMMERSION LED (DMX signal) or with the SOFT TOUCH system if you want to control the light intensity

- LED Power RGB for IMMERSION LED can drive up to 5 LED projectors
- The projector need to be completed with LED drivers (with max 24Vcd out) if you want the On/Off version
- Plastic housing for installation is included
- The projector comes with 6m cable included
- M16 cable clamp for LED supply
- Available 4 type of lenses: 6° Narrow; 25° Medium; 45° Wide beam and 110° Very Wide beam

HOLE for installation

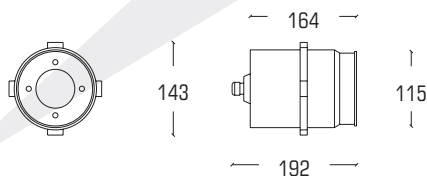
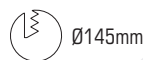

2,03 Kg



## **DRIVERS & POWER SUPPLIES**

**LAMPO LIGHTING DESIGNERS / LED TECHNOLOGY AND ARCHITECTURAL LIGHTING / 2009**





## RGB AND WHITE DIMMER SYSTEM

- LED POWER RGB is a dedicated driver for all types of LEDs colour changers without electronic (L.B.9; mini chic; mini ceiling etc.)
- LED POWER RGB can drive projectors connected in series
- It can drive projectors with RGB LEDs or White LEDs
- Main voltage: from 85V to 265V 50/60Hz
- LEDs are driven @ 350mA (700mA on request)
- Series connection: max. 40 meters total length connection cable
- Electronic board 8/16 bit resolution with 4 digit display
- Works via DMX signal (From 1 to 14 channels)
- Works in automatic mode
- Master / Slave functions
- There are two versions: for in-door (IP30) or out-door (IP65) applications
- Out-door version: Aluminium box IP65 protection rate with cable clamps, power block connector for LEDs connection, power Supply and DMX signal
- In-door version: Aluminium case IP30 protection rate, RJ45 female connector for LEDs, XLR 3 pin (5 pin on request) for DMX signal, Plug for power supply (female plug included)
- On request IR sensor for remote control

## LED POWER RGB can drive:

- Max 10 projectors with 3 LEDs 1.2W
- Max 4 projectors with 9 LEDs 1.2W
- Max 2 projectors with 18 LEDs 1.2W

## WHITE SYSTEM

- LED POWER WHITE is a dedicated driver for all types of LEDs without electronic inside (L.B.9; mini chic; mini ceiling etc.)
- LED POWER WHITE can drive some projectors connected in series or single projector with White or monochrome LEDs, in On/Off version

- Standard drivers as follows (other drivers available on request):

- LED Power White 350mA 3W, Vin from 220V to 240V (3 LEDs)
- LED Power White 350mA 16,8W, Vin from 220V to 240V (12 LEDs)
- LED Power White 700mA 16,8W, Vin from 220V to 240V (6 LEDs)
- LED Power White 350mA 22W, Vin from 110V to 230V (18 LEDs)
- LED Power White 350mA 8,5W, Vin 24Vdc (6 LEDs)
- LED Power White 700mA 16,8W, Vin 24Vdc (6 LEDs)

### LED Power rgb IP30

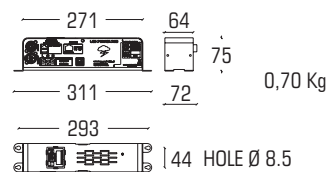

### LED Power rgb IP65

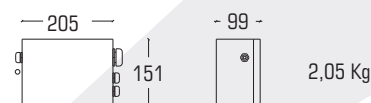

### LED power white 22W

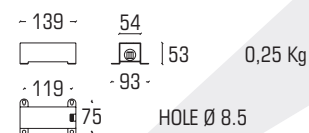

### LED power white 24Vdc

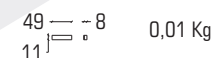

### LED power white 16,8W



### LED power white 3W

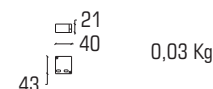



## RGB AND WHITE DIMMER SYSTEM

- LED POWER RGB for IMMERSION LED is a dedicated driver for IP68 LEDs projectors (Nemo Led; Mini Nemo; Mini Sub)
- LED POWER RGB for IMMERSION LED can drive projectors connected in series
- It can drive projectors with RGB LEDs or White LEDs
- Main voltage: 230V 50Hz (24Vdc out)
- LEDs are driven @ 350mA
- Series connection: max. 40 meters total length connection cable
- Electronic board inside
- Works via DMX signal (8 channels)
- Works in automatic mode
- IP65 protection rate
- Aluminium box
- Grey finished
- Cable clamp PG13.5 for power supply
- Two cable clamps PG9 for DMX signal cable
- Cable clamp PG9 for LED supply

## LED POWER RGB FOR IMMERSION LED CAN DRIVE:

Max 1 Nemo LED

Max 6 Mini Nemo or 6 Mini Sub

## MONOCHROMATIC SYSTEM FOR IMMERSION LED

- LED POWER ON/OFF for IMMERSION LED has 24 Vdc input and max 24Vdc output
- LED POWER WHITE can drive some projectors connected in series or single projector with White or monochrome LEDs, in On/Off version
- To drive more fixtures it's possible to use many LED Power white (ask for custom configuration)
- Standard drivers below (other drivers available on request)
- LED Power White 350mA (Vout 24Vdc) 8,5W, Vin 24Vdc (2 Mini Nemo or 2 Mini Sub)
- LED Power White 700mA (Vout 24Vdc) 16,8W, Vin 24Vdc (2 Mini Nemo or 2 Mini Sub)

## LED Power rgb IP65 for immersion LED

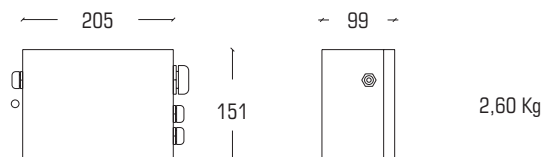

## LED power white 24Vdc



# SOFT TOUCH SYSTEM & SWITCHING

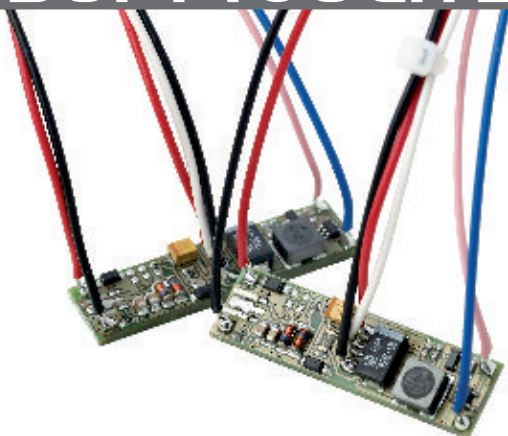

**DRIVER**



**SINGLE**



**TRIO**



**RGB**



**SWITCHING**

## SOFT TOUCH SYSTEM

- New way to control your LED devices
- Very easy to use (no console or DMX needed)
- Suitable for all the applications where you need design and technology at the same time
- SOFT TOUCH DRIVE is needed to use the soft touch system
- Suitable also for class III underwater projectors

## SOFT TOUCH DRIVE

- Power driver for power LED
- Input: 24Vdc
- Output current 350mA
- Can drive up to 6 LED
- To drive more LED you can use more SOFT TOUCH DRIVE with the same controller
- 12 Vdc output to power up the SOFT TOUCH SINGLE
- Dimmer functions (with controller connected)

## SOFT TOUCH SINGLE

- Touch button with backlighting LED system
- Available in different backlighting colours: white, red, green, blue, amber
- Dimmering function from 20 to 100%
- ON/OFF function
- White or black anodized finished
- Main 12Vdc from SOFT TOUCH DRIVE

## SOFT TOUCH TRIO

- 3 Touch button with backlighting LED system in standard 503 unit

- Available in different backlighting colours: white, red, green, blue, amber
- Dimmering function from 20 to 100%
- ON/OFF function
- Possibility to control 3 LED line separately (with 1 or more DRIVE each line)
- Main 24Vdc
- 3 SOFT TOUCH DRIVE minimum to control 18 (6 LEDs for each button)

## SOFT TOUCH RGB

- 3 Touch button with backlighting LED system in standard 503 unit
- Suitable for RGB units
- ON/OFF function
- Fixed colours with dimmer function
- Rainbow function with variable speed
- Record function on customized colour
- Possibility to control 3 LED line separately (with 1 or more DRIVE each channel)
- Main 24Vdc
- 3 SOFT TOUCH DRIVE minimum to control 18 rgb LEDs (6 red, 6 green, 6 blue)

## SWITCHING

- Suitable for different uses
- Available in different size: 25W, 50W, 75W, 100W, 150W
- 24 Vdc output
- Main supply from 100 to 260V 50/60 Hz

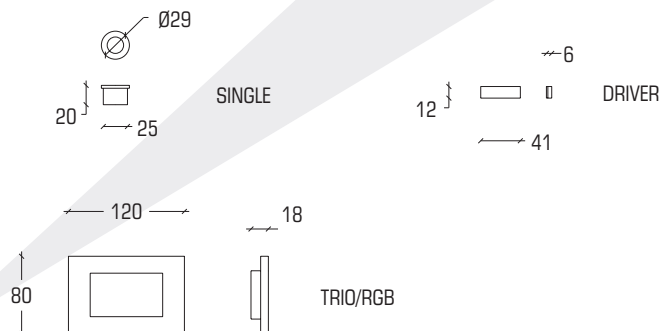



A photograph of a modern building at night, featuring a central dome and multiple arches. The building is illuminated with vibrant blue and red lights, creating a striking contrast against the dark sky. The dome is topped with a small spire. The building's facade is composed of light-colored panels and large glass windows. The overall scene is a dramatic architectural lighting display.

# **CONTROLLERS & ACCESSORIES**

**LAMPO LIGHTING DESIGNERS / LED TECHNOLOGY AND ARCHITECTURAL LIGHTING / 2009**



## PLUS 2048

PLUS 2048 is a DMX/RDM interface based on ARTNET protocol over Ethernet  
 PLUS 2048 is a DMX/RDM splitter with 4 channels output  
 PLUS 2048 is a DMX/ARTNET recorder and playback

- User friendly DMX interface, ArtNet Node with 4 DMX output universes
- Simple DMX/RDM splitter 1 input / 4 output
- ArtNet/DMX recording and playback capabilities
- Scene recording on standard SD card
- Timecode function
- Every parameter set-up is possible with built-in web page
- Can be installed in RACK 19" - 1 unit
- IP20 protection rate, without fan
- Aluminium body
- Black finished
- 4 DMX optocoupled output ports, support for ArtNet protocol over Ethernet
- Configurable DMX break duration and refresh rate
- Configurable universe and number of channel for each port
- LED status indicator for each port
- Main voltage: 230V 50/60Hz



AS103



AS104

## LIGHT MASTER

LIGHT MASTER is a standard DMX 512 signal console, it is available in two versions: with 24 or 48 DMX channels.

- 4 pages containing 12 or 24 programs each, up to 4600 programmable scenes
- Possibility to modify the scene in real time or off-line
- Adjustable time and scene speed
- Midi scene sync. – Microphone - Audio input
- 3 Pin XLR output connectors
- 24 channels: 4.4Kg - L482xW266xH95mm
- 48 channels: 6.2Kg - L710xW266xH95mm

## PLUS 2042



404



152

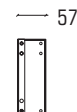

2,60 Kg



## LED CONTROLLER

Any DMX 512 controller can drive LED projectors but LED CONTROLLER is a dedicated console for LED rgb colour changers, very easy to use.

- Plastic body, wall mounting with rear holes
- Display LCD green 168x64 pixel
- Multifunctional 5 digit keyboard
- 4 programs, 36 scenes
- Can control up to 6 groups of projectors
- 48 dmx channels
- Power supply included (230V 50/60Hz)
- Dimensions: 97x98mm



## LED REMOTE

LED REMOTE is an infra-red remote controller for the LED colour changers

- To use this device, the projector must be set on IR mode
- LED remote can be used as a manual control or it can activate projector's pre-set scenes
- In manual control you can select any colour and light intensity
- If you activate the pre-set scenes, the projector will run a pre-set sequence of colours
- With the remote control it is possible to drive the projector up to a 10m distance (without optical obstacles)



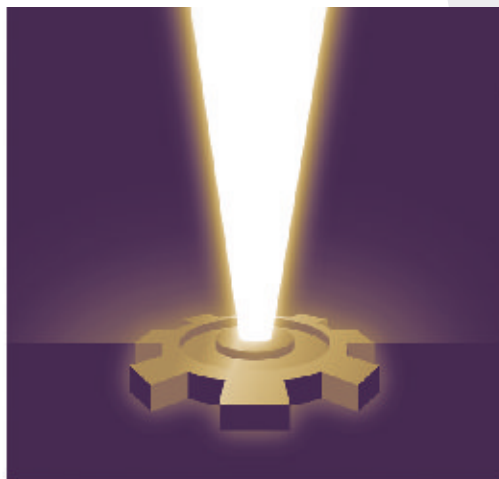

## LIGHTFACTORY

**LIGHT FACTORY SOFTWARE** is a unique PC based lighting control system.

Offering a no compromise approach of traditional dimmer control and fully featured moving light and colour changer support.

Light Factory was designed with the idea that every lighting engineer, operator or designer could own their own control desk.

One desk they are completely familiar with, one desk that works for every situation and one desk they can rely on every time.

Most PC based control systems focus on moving light support but lack the many features that make traditional lighting desks stand out.

Light Factory closes that gap.

For more detail visit web site

**[www.lifactory.com](http://www.lifactory.com)**

There are different versions of software

Description:

- Up to 64 DMX universes (37,768 DMX channels)
- Up to 10,000 lighting fixtures
- Output to industry standard USB or Ethernet devices
- Unlimited cue lists each supporting millions of cue
- Multiple effects engines
- Built in scheduler, macros, palettes, user security and fixture library
- Audio, MIDI, and Timecode triggering
- Up to 1000 external submasters using any existing DMX desk
- Unique LED / Matrix Control
- Simple media playback (Video, Audio, Flash)
- Capture & WYSIWYG Visualisation Support
- Free wireless rigging remote software

# WWW.LIFACTORY.COM

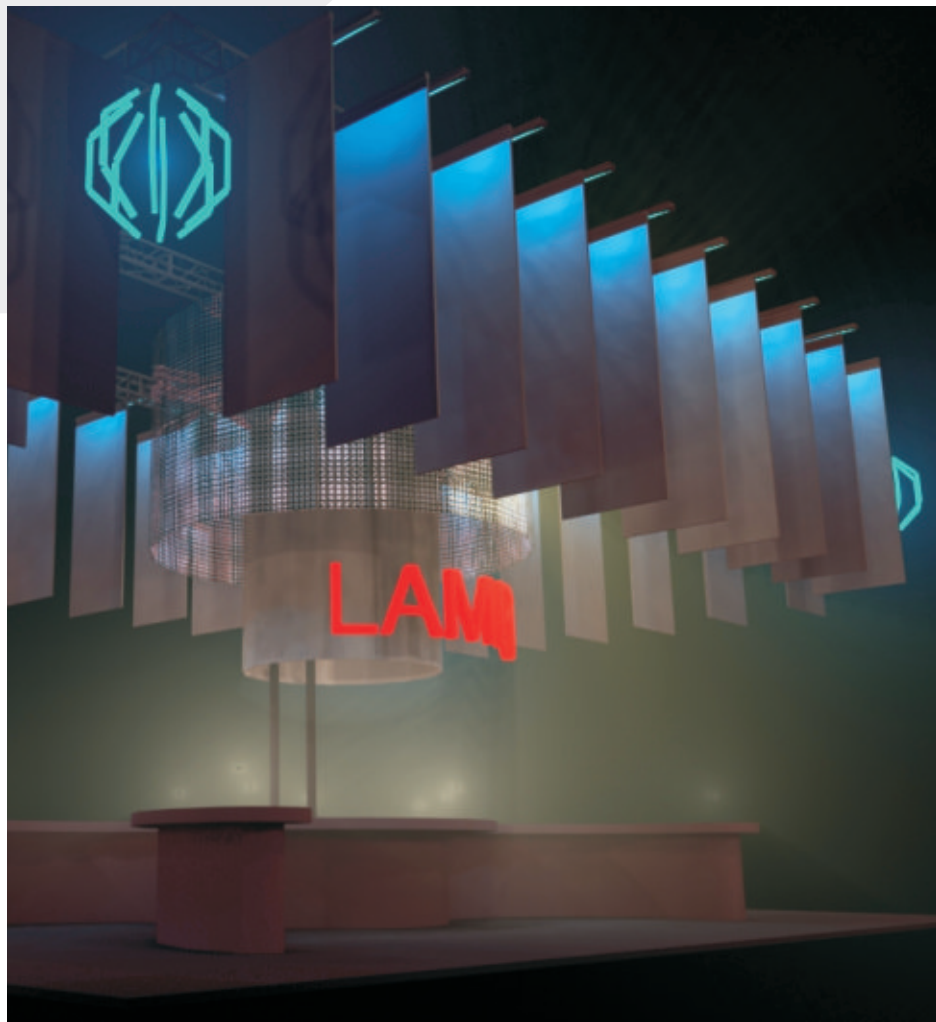
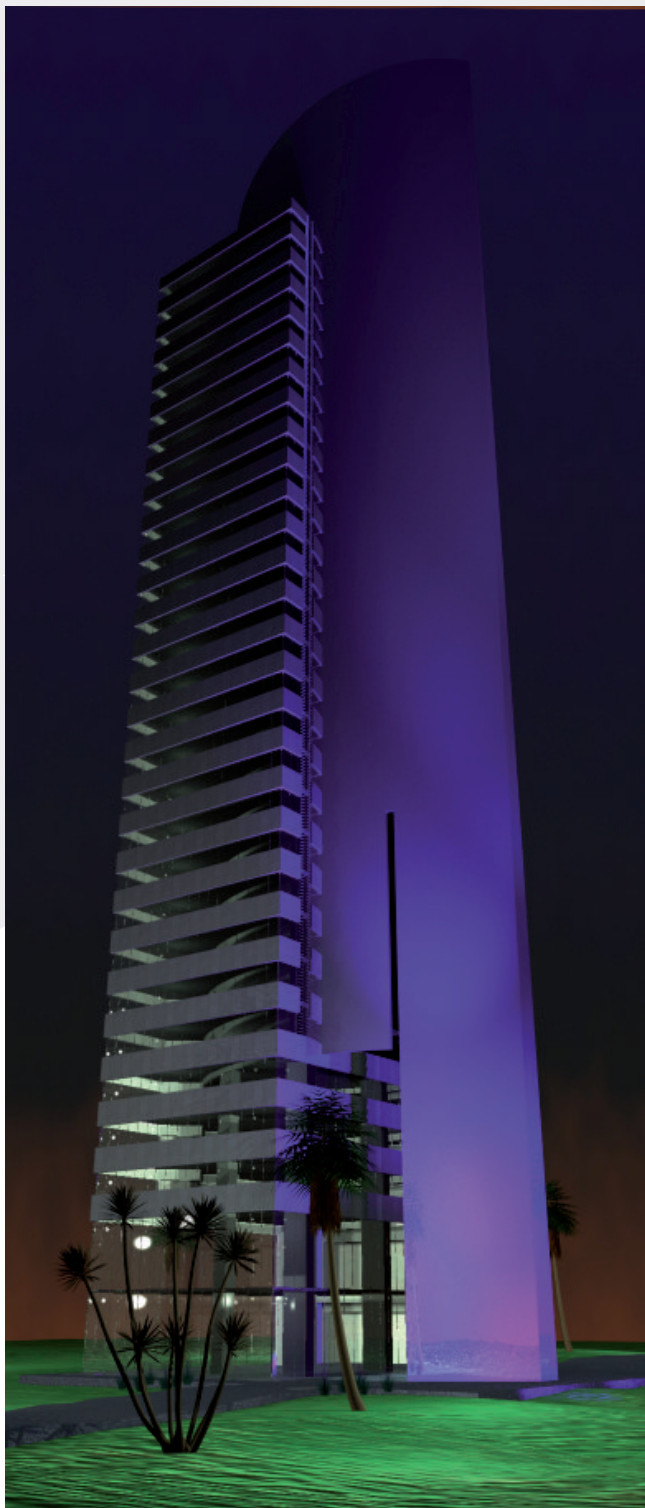

As from this year LAMPO has the pleasure to co-operate with an internationally known lighting designer, Mr **Steve Gray**. Available on request 3D renderings.



LAMPO Lighting Designers S.r.l.  
Via Portogallo, 4  
46042 Castel Goffredo (MN) Italy  
Tel. +39.0376.770869  
Fax +39.0376.780947  
[info@lamposrl.it](mailto:info@lamposrl.it)  
[www.lamposrl.it](http://www.lamposrl.it)